

Power-Quality Improvement with Grid Interconnection of Renewable Energy Source at the Distribution Level at Different Loads

¹P.MANJUSHA, ²P.L SRAVANI, ³Y. VARALAKSHMI

¹Associate Professor, ²Associate Professor, ³Associate Professor Department of EEE
VSM COLLEGE OF ENGINEERING, RAMACHANDRAPURAM

Abstract: A Power quality problem is an occurrence of nonstandard voltage, current or frequency that results in a failure or a misoperation of end user equipments. Utility distribution networks, sensitive industrial loads and critical commercial operations suffer from various types of outages and service interruptions which can cost significant financial losses. With the increase in load demand, the Renewable Energy Sources (RES) are increasingly connected in the distribution systems which utilizes power electronic Converters/Inverters. This paper presents a novel control strategy for achieving maximum benefits from these grid-interfacing inverters using the closed loop fuzzy logic control, when installed in 3-phase 4-wire distribution systems. The inverter is controlled to perform as a multi-function device by incorporating active power filter functionality. The inverter can thus be utilized as: 1) power converter to inject power generated from RES to the grid, and 2) shunt APF to compensate current unbalance, load current harmonics, load reactive power demand and load neutral current. All of these functions may be accomplished either individually or simultaneously. This new control concept is demonstrated with extensive MATLAB/Simulink.

Keywords: Active power filter (APF), distributed generation (DG), distribution system, grid interconnection, power quality (PQ), renewable energy, Photo Voltaic (PV) System

1. Introduction

Power electronics devices are widely used in different fields and for different practical applications. The expansion of their field of applications is related to the knowledge of the device behaviour and of their performances [2]. One of the most interesting field of application is load compensation, i.e. active filtering of load harmonics, load unbalance and / or load power factor compensation. Both items require a proper drive of power electronics apparatus. The harmonic components in current and voltage waveforms are the most important among these. Conventionally [4]-[6], passive filters have been used to eliminate line current harmonics. However, they introduce resonance in the power system and tend to be bulky. So active power line conditioners have become popular than passive filters as it compensates the harmonics and reactive power simultaneously [1]. The active power filter topology can be connected in series or shunt and combinations of both [8]. Shunt active filter is more popular than series active filter because most of the industrial applications require current harmonics compensation. Different types of active filters have been proposed [10] to increase the electric system quality; a generalized block diagram of active power filter is presented. Active power filter continues to attract considerable attention Because of sensitivity of consumers on power quality and advancement in power electronics.

Active power filter technology is the most efficient way to compensate reactive power and cancel out low order harmonics generated by nonlinear loads. The electrical grid will include a very large number of small producers [5] that use renewable energy sources, like solar panels or wind generators. One of the most common problems when connecting small renewable energy systems to the electric grid concerns the interface unit between the power sources and the grid, because it can inject harmonic components that may deteriorate the power quality. However, the extensive use of power electronics based equipment and non-linear loads at PCC generate harmonic currents, which may deteriorate the quality power.

Renewable energy systems such as PV, solar thermal electricity such as dish-stirling systems, and WT are appropriate solar and wind technologies that can be considered for electric power generation at the distribution system level. Other renewable energy technologies, such as the solar central receiver, hydro-electric generation, geothermal, and large wind farms are normally connected to the grid at the sub-transmission or transmission level because of the higher power capacities of these types of systems. Due to increasing air pollution, global warming concerns, diminishing fossil fuels and their increasing cost have made it necessary to look towards Renewable Energy Sources (RES) as a future energy solution. Renewable Energy Sources are increasingly integrated at the distribution level due to increase in load demand which

utilize power electronic converters. Due to the extensive use of power electronic devices, disturbances occur on the electrical supply network. These disturbances are due to the use of non-linear devices. These will introduce harmonics in the power system thereby causing equipment overheating, damage devices, EMI related problems etc. Active Power Filters (APF) is extensively used to compensate the current harmonics and load unbalance.

Generally, current controlled voltage source inverters are used to interface the intermittent RES in distributed system. Recently, a few control strategies for grid connected inverters incorporating PQ solution have been proposed. In [3] an inverter operates as active inductor at a certain frequency to absorb the harmonic current. But the exact calculation of network inductance in real-time is difficult and may deteriorate the control performance. A similar approach in which a shunt active filter acts as active conductance to damp out the harmonics in distribution network is proposed in [4]. In [5], a control strategy for renewable interfacing inverter based on – theory is proposed. In this strategy both load and inverter current sensing is required to compensate the load current harmonics. Here, the main idea is the maximum utilization of inverter rating which is most of the time underutilized due to intermittent nature of RES. It is shown in this paper that the grid-interfacing inverter can effectively be utilized to perform following important functions: 1) transfer of active power harvested from the renewable resources (wind, solar, etc.); 2) load reactive power demand support; 3) current harmonics compensation at PCC; and 4) current unbalance and neutral current compensation in case of 3-phase 4-wire system. Moreover, with adequate control of grid-interfacing inverter, all the four objectives can be accomplished either individually or simultaneously. The PQ constraints at the PCC can therefore be strictly maintained within the utility standards without additional hardware cost. Approximately 70 to 80% of all power quality related problems can be attributed to fault connections and/or wiring [2]. Power frequency disturbances, electromagnetic interference, transients, harmonics and low power factor are the other categories of PQ problems (shown in table 1) that are related to the supply and types of load [3].

Among these events, harmonics are the most dominant one. The effects of harmonics on PQ are specially described in [4]. According to the IEEE standard, harmonics in the power system should be limited by two different methods; one is the limit of harmonic current that a user can inject into the utility system at the point of common coupling (PCC) and the other is the limit of harmonic voltage that the can supply to any customer at

the PCC. DG interconnection standards are to be followed considering PQ, protection and stability issues [6].

2. System Description

The proposed system consists of RES connected to the dc-link of a grid-interfacing inverter as shown in Fig. 1. The voltage source inverter is a key element of a DG system as it interfaces the renewable energy source to the grid and delivers the generated power. The RES may be a DC source or an AC source with rectifier coupled to dc-link. Usually, the fuel cell and photovoltaic energy sources generate power at variable low dc voltage, while the variable speed wind turbines generate power at variable ac voltage. Thus, the power generated from these renewable sources needs power conditioning (i.e., dc/dc or ac/dc) before connecting on dc-link [6]–[8]. The dc-capacitor decouples the RES from grid and also allows independent control of converters on either side of dc-link.

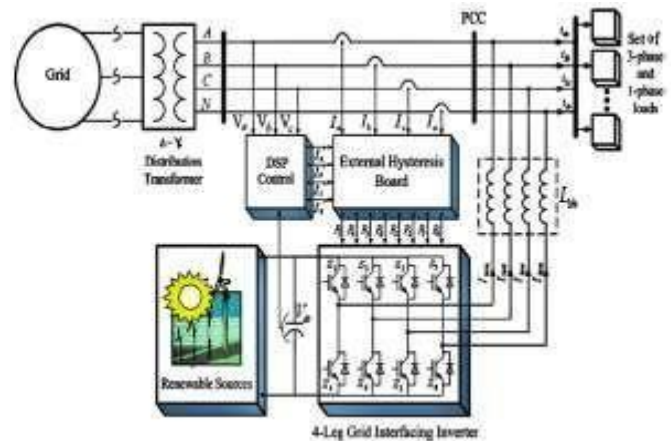

Figure 1: Schematic of proposed renewable based distributed generation system.

A. DC-Link Voltage and Power Control Operation

Due to the intermittent nature of RES, the generated power is of variable nature. The dc-link plays an important role in transferring this variable power from renewable energy source to the grid. RES are represented as current sources connected to the dc-link of a grid-interfacing inverter. Fig. 2 shows the systematic representation of power transfer from the renewable energy resources to the grid via the dc-link. The current injected by renewable into dc-link at voltage level V_{dc} can be given as

$$I_{dc1} = \frac{P_{RES}}{V_{dc}} \quad (1)$$

Where P_{RES} is the power generated from RES.

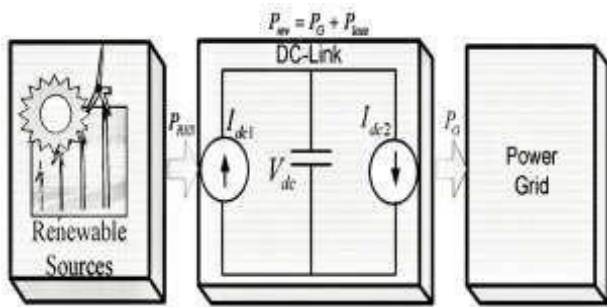

Figure 2: DC-Link equivalent diagram.

The current flow on the other side of dc-link can be represented as,

$$I_{dc2} = \frac{P_{inv}}{V_{dc}} = \frac{P_G + P_{Loss}}{V_{dc}} \quad (2)$$

Where P_{inv} , P_G and P_{Loss} are total power available at grid-interfacing inverter side, active power supplied to the grid and inverter losses, respectively. If inverter losses are negligible then $P_{RES} = P_G$.

B. Control of Grid Interfacing Inverter

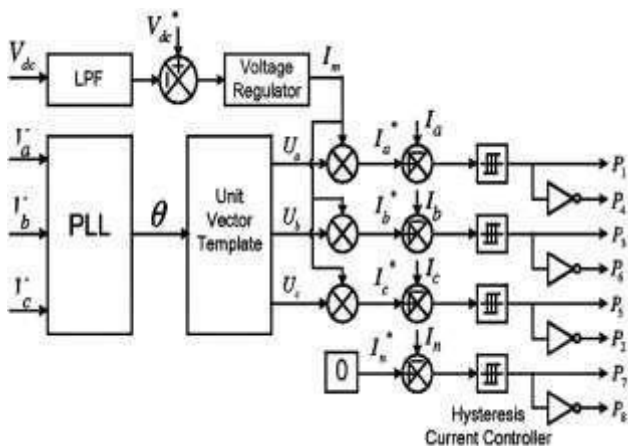

Figure 3: Block diagram representation of grid-interfacing inverter control

The control diagram of grid- interfacing inverter for a 3-phase 4-wire system is shown in Fig. 3. The fourth leg of inverter is used to compensate the neutral current of load. The main aim of proposed approach is to regulate the power at PCC during:

- 1) $P_{RES} = 0$; 2) $P_{RES} < \text{Total load power } (P_L)$; and 3) $P_{RES} > P_L$.
- While performing the power management operation, the inverter is actively controlled in such a way that it always draws/ supplies fundamental active power from/ to the grid. If the load connected to the PCC is non-linear or

unbalanced or the combination of both, the given control approach also compensates the harmonics, unbalance, and neutral current. The duty ratio of inverter switches are varied in a power cycle such that the combination of load and inverter injected power appears as balanced resistive load to the grid. The regulation of dc-link voltage carries the information regarding the exchange of active power in between renewable source and grid. Thus the output of dc-link voltage regulator results in an active current (I_m). The multiplication of active current component (I_m). With unity grid voltage vector templates (U_a, U_b , and U_c) generates the reference grid currents (I_a^*, I_b^* , and I_c^*). The reference grid neutral current (I_n^*) is set to zero, being the instantaneous sum of balanced grid currents. The grid synchronizing angle (θ) obtained from phase locked loop (PLL) is used to generate unity vector template as [9]-[11]

$$U_a = \sin(\theta) \quad (3)$$

$$U_b = \sin(\theta - \frac{2\pi}{3}) \quad (4)$$

$$U_c = \sin(\theta + \frac{2\pi}{3}) \quad (5)$$

The actual dc-link voltage (V_{dc}) is sensed and passed through a first-order *low pass filter* (LPF) to eliminate the presence of switching ripples on the dc-link voltage and in the generated reference current signals. The difference of this filtered dc-link voltage and reference dc-link voltage (V^*) is given to a discrete- PI regulator to maintain a constant dc-link voltage under varying generation and load conditions. The dc-link voltage error $V_{dcerr}(n)$ at nth sampling instant is given as:

$$V_{dcerr}(n) = V_{dc}^*(n) - V_{dc}(n) \quad (6)$$

The output of discrete-PI regulator at th sampling instant is expressed as

$$I_m(n) = I_m(n-1) + K_{PVdc}(V_{dcerr}(n) - V_{dcerr}(n-1)) + K_{IVdc} V_{dcerr}(n) \quad (7)$$

Where $K_{PVdc} = 10$ and $K_{IVdc} = 0.05$ are proportional and integral gains of dc-voltage regulator. The instantaneous values of reference three phase grid currents are computed as

$$I_a^* = I_m \cdot U_a \quad (8)$$

$$I_c^* = I_m \cdot U_c \quad (9)$$

$$I_n^* = 0 \quad (10)$$

The neutral current, present if any, due to the loads connected to the neutral conductor should be compensated by fourth leg of grid-interfacing inverter and thus should not be drawn from the grid. In other words, the reference current for the grid neutral current is considered as zero and can be expressed as

$$I_n^* = 0 \quad (11)$$

The reference grid currents (I^*a, I^*b, I^*c and I^*n) are compared with actual grid currents (I_a, I_b, I_c and I_n) to compute the current errors as

$$I_{acrr} = I^*_a - I_a \tag{12}$$

$$I_{bcrr} = I^*_b - I_b \tag{13}$$

$$I_{ccrr} = I^*_c - I_c \tag{14}$$

$$I_{ncrr} = I^*_n - I_n \tag{15}$$

These current errors are given to hysteresis current controller. The hysteresis controller then generates the switching pulses (P_1 to P_8) for the gate drives of grid-interfacing inverter. The average model of 4-leg inverter can be obtained by the following state space equations

$$\frac{dI_{Inva}}{dt} = \frac{V_{Inva} - V_a}{L_{sh}} \tag{16}$$

$$\frac{dI_{Invb}}{dt} = \frac{V_{Invb} - V_b}{L_{sh}} \tag{17}$$

$$\frac{dI_{Invc}}{dt} = \frac{V_{Invc} - V_c}{L_{sh}} \tag{18}$$

$$\frac{dI_{Invn}}{dt} = \frac{V_{Invn} - V_n}{L_{sh}} \tag{19}$$

$$\frac{dV_{dc}}{dt} = \frac{(I_{Invad} + I_{Invbd} + I_{Invcd} + I_{Invnd})}{C_{dc}} \tag{20}$$

Where $V_{Inva}, V_{Invb}, V_{Invc}$ and V_{Invn} are the three-phase ac switching voltages generated on the output terminal of inverter.

These inverter output voltages can be modeled in terms of instantaneous dc bus voltage and switching pulses of the inverter as

$$V_{Inva} = \frac{(P_1 - P_4)}{2} V_{dc} \tag{21}$$

$$V_{Invb} = \frac{(P_3 - P_6)}{2} V_{dc} \tag{22}$$

$$V_{Invc} = \frac{(P_5 - P_2)}{2} V_{dc} \tag{23}$$

$$V_{Invn} = \frac{(P_7 - P_8)}{2} V_{dc} \tag{24}$$

Similarly the charging currents $I_{Invad}, I_{Invbd}, I_{Invcd}$ and I_{Invnd} on dc bus due to the each leg of inverter can be expressed as

$$I_{Invad} = I_{Inva} (P_1 - P_4) \tag{25}$$

$$I_{Invbd} = I_{Invb} (P_3 - P_6) \tag{26}$$

$$I_{Invcd} = I_{Invc} (P_5 - P_2) \tag{27}$$

$$I_{Invnd} = I_{Invn} (P_7 - P_8) \tag{28}$$

The switching pattern of each IGBT inside inverter can be formulated on the basis of error between actual and reference current of inverter, which can be explained as:

If $I_{Inva} < (I^*_{Inva} - h_b)$, then upper switch S_1 will be OFF ($P_1 = 0$) and lower switch S_4 will be ON ($P_4 = 1$) in the phase "a" leg of inverter.

If $I_{Inva} > (I^*_{Inva} + h_b)$, then upper switch S_1 will be ON ($P_1 = 1$) and lower switch S_4 will be OFF ($P_4 = 0$) in the phase "a" leg of inverter. Where h_b is the width of hysteresis band. On the same principle, the switching pulses for the other remaining three legs can be derived.

3. Renewable Energy Resources

Renewable energy resources are the ones that are persistently available and renewing itself with the time. Industrialization and increasing world population has remarked the use of renewable energy resources. Solar power, wind power, biomass, tide power, wave power, geothermal power is known ones.

A) Solar Power

Solar panels are the medium to convert solar power into the electrical power. Solar panels can convert the energy directly or heat the water with the induced energy. PV (Photo-voltaic) cells are made up from semiconductor structures as in the computer technologies. Sun beam is absorbed with this material and electrons are emitted from the atoms that they are bounded. This release activates a current. Photovoltaic is known as the process between beam absorbed and the electricity induced. With a common principle and individual components, solar power is converted into the electric power. Solar batteries are produced by wafling p-n semiconductors. A current-volt characteristic of the PV in the darkness is very similar to that of diot. Under beam, electron flow and current occurs. In closed-loop, PV current passes through the external load. While in open-loop, the current completes the circuit through the p-n diode structure [4]. Solar batteries can be represented with an equivalent circuit of a current source, a resistor and a diot in parallel, and an external load- resistor [5], as seen in Figure 4.

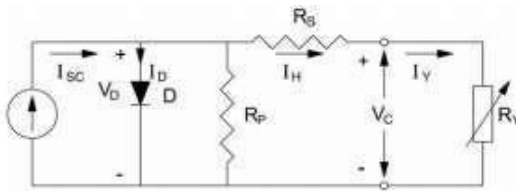

Figure 4: Equivalent circuit of solar battery

It is possible to insert AC-DC converter, charger, accumulator, extra power source, and controller depending on the design differences in operational and functional specifications [6]. Solar system could be categorized into two types: Line-independent systems: These are established in absence of line electricity to provide electricity. Since the current in these systems are DC and it must be also available overnight, energy is stored in accumulators, DC-Batteries. In case of AC Supply requirements for the appliances, it is possible to use DC-AC inverter [6]. Line-dependent systems: These systems do not need DC Batteries, since the energy is served to the demand with the help of an inverter. Line electricity is being switched in use in case of insufficient sun beam [6].

B) Wind Power

Wind turbines are used to convert the wind power into electric power. Electric generator inside the turbine converts the mechanical power into the electric power. Wind turbine systems are available ranging from 50W to 2-3 MW. The energy production by wind turbines depends on the wind velocity acting on the turbine. Wind power is used to feed both energy production and consumption demand, and transmission lines in the rural areas. Wind turbines can be classified with respect to the physical features (dimensions, axes, number of blade), generated power and so on. For example, wind turbines with respect to axis structure: horizontal rotor plane located turbines, turbines with vertical or horizontal spinning directions with respect to the wind. Turbines with blade numbers: 3-blade, 2-blade and 1- blade turbines.

On the other hand, power production capacity based classification has four subclasses [7].

- Small Power Systems
- Moderate Power Systems
- Big Power Systems
- Megawatt Turbines

C) Design and Implementation of Domestic Solar-Wind Hybrid Energy System

Hybrid systems are the ones that use more than one energy resources. Integration of systems (wind and solar) has more influence in terms of electric power production. Such systems are called as “hybrid systems”. Hybrid solar-wind applications are implemented in the field, where all-year energy is to be consumed without any chance for an interrupt. It is possible to have any combination of energy resources to supply the energy demand in the hybrid systems, Such as oil, solar and wind. This project is similar with solar power panel and wind turbine power. Differently, it is only an add-on in the system. Photovoltaic solar panels and small wind turbines depend on climate and weather conditions. Therefore, neither solar nor wind power is sufficient alone. A number of renewable energy expert claims to have a satisfactory hybrid energy resource if both wind and solar power are integrated within a unique body. In the summer time, when sun beams are strong enough, wind velocity is relatively small. In the winter time, when sunny days are relatively shorter, wind velocity is high on the contrast. Efficiency of these renewable systems show also differences through the year. In other words, it is needed to support these two systems with each other to sustain the continuity of the energy production in the system.

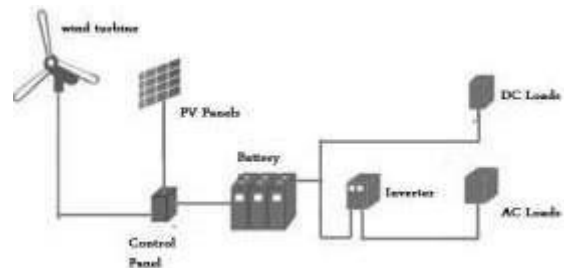

Figure 5: Hybrid system

In the realized system, a portion of the required energy for an ordinary home has been obtained from electricity that is obtained from the wind and solar power. Experimental setup for the domestic hybrid system consists of a low power wind turbine and two PV panel. Depending on the environmental conditions, required energy for the system can be supplied either separately from the wind or solar systems or using these two resources at the same time is in show Fig 5. Control unit decides which source to use for charging the battery with respect to condition of the incoming energy as seen in Figure 6.

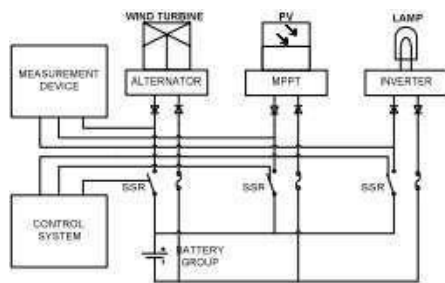

Figure 6: System block diagram

Wind turbine first converts the kinetic energy to mechanical energy and then converts it to the electricity. The wind turbine in the system consists of tower, alternator, and speed converters (gear box), and propeller. And a picture of the constructed hybrid system is The kinetic energy of the wind is converted to the mechanical energy in the rotor. The rotor shaft speed, 1/18, is accelerated in the reduction gear and then transmitted to alternator. The electricity that comes from the alternator can be directly transmitted to DC receivers as well as it can be stored in the batteries.

4. MATLAB Modeleimg and Simulation Results

To verify the proposed control approach to achieve the multi function of four leg inverter simulation study is carried out using MATLAB/Simulink. Here simulation is carried out in different cases 1). Implementation of 4-Leg VSI with Balanced Linear Load Condition 2). Implementation of 4-Leg VSI with Un-Balanced Linear Load Condition 3). Implementation of 4-Leg VSI with Balanced Non- Linear Load Condition 4). Implementation of 4-Leg VSI with Un- Balanced Non Linear Load Condition. 5). Implementation of 4-Leg VSI with Un-Balanced Variable Non Linear Load Condition.

Case 1: Implementation of 4-Leg VSI with Balanced Linear Load Condition

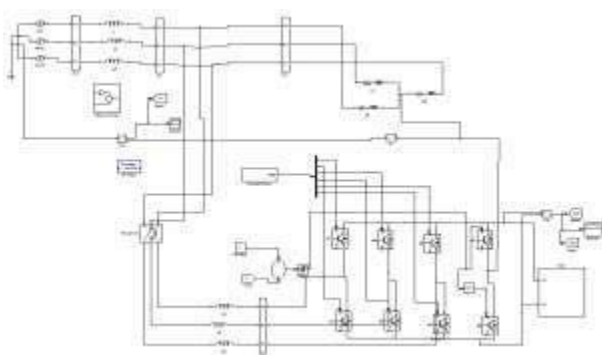

Figure 7: Matlab/Simulink Model of Proposed 4-Leg VSI with Balanced Linear Load Condition

Fig.7 shows the Matlab/Simulink Model of Proposed 4-Leg VSI with Balanced Linear Load Condition using Matlab/Simulink Platform.

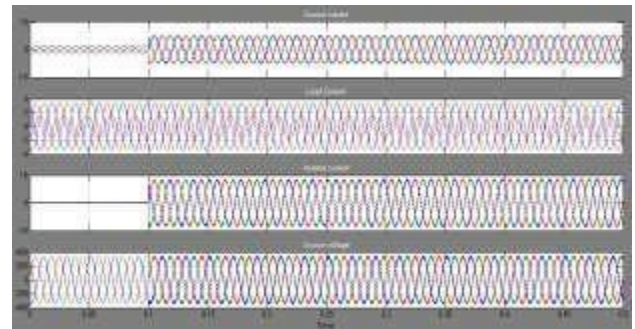

Figure 8: Source Current, Load Current, Inverter Injecting Current, Grid Voltage

Fig.8 shows the Source Current, Load Current, Inverter Injecting Current, and Grid Voltage of Proposed 4-Leg VSI with Balanced Linear Load Condition.

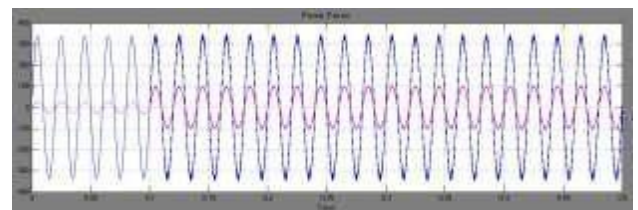

Figure 9: Power Factor

Fig.9 shows the Power Factor of Proposed 4-Leg VSI with Balanced Linear Load Condition.

Case 2: Implementation of 4-Leg VSI with Un-Balanced Linear Load Condition

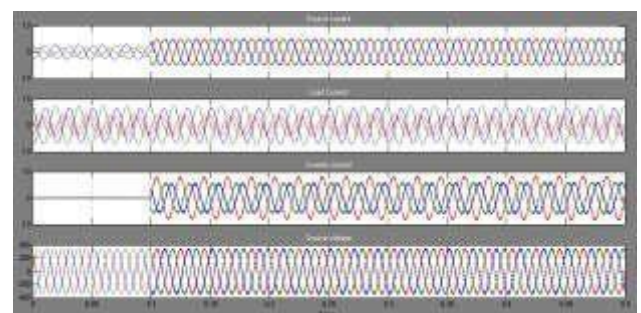

Figure 10: Source Current, Load Current, Inverter Injecting Current, Grid Voltage

International Conference on Recent Trends in Engineering & Technology- 2023 (ICRTET-3)
 Organised by: VSM College of Engineering, Ramachandrapuram

Fig.10 shows the Source Current, Load Current, Inverter Injecting Current, and Grid Voltage of Proposed 4-Leg VSI with Un-Balanced Linear Load Condition, due to unwanted impedance our source parameters distorts, but compensate using the compensator.

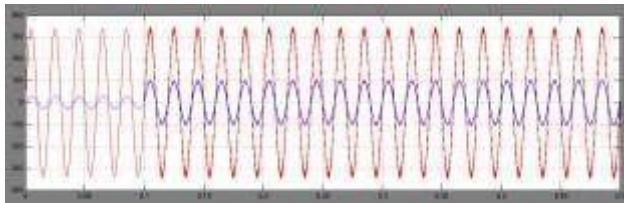

Figure 11: Power Factor

Fig.11 shows the Power Factor of Proposed 4-Leg VSI with Un-Balanced Linear Load Condition.

Case 3: Implementation of 4-Leg VSI with Balanced Non-Linear Load Condition

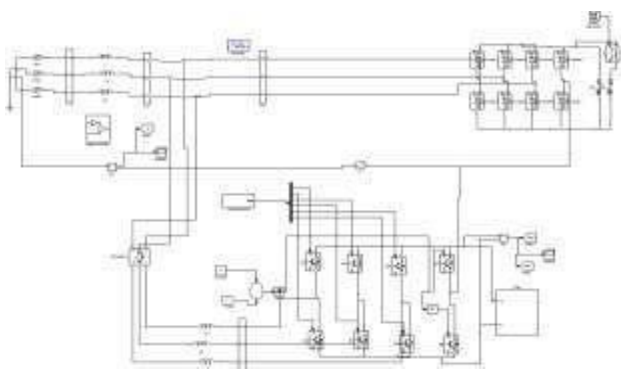

Figure 12: Matlab/Simulink Model of Proposed 4-Leg VSI with Balanced Non Linear Load Condition

Fig.12 shows the Matlab/Simulink Model of Proposed 4-Leg VSI with Balanced Non Linear Load Condition using Matlab/Simulink Platform.

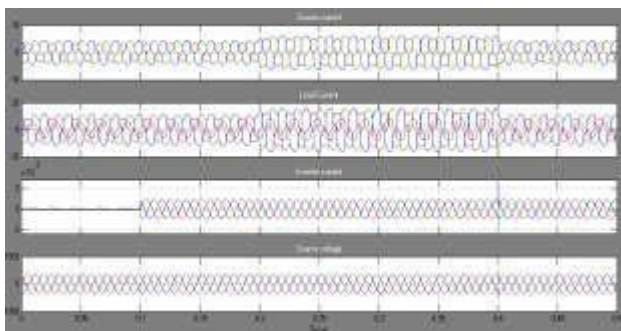

Figure 13: Source Current, Load Current, Inverter Injecting Current, Grid Voltage

Fig.13 shows the Source Current, Load Current, Inverter Injecting Current, and Grid Voltage of Proposed 4-Leg without VSI with Balanced Non Linear Load Condition, due to non linear load our source parameters distorts.

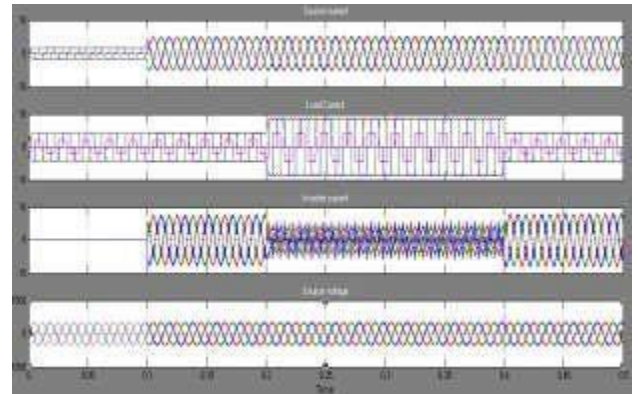

Figure 14: Source Current, Load Current, Inverter Injecting Current, Grid Voltage

Fig.14 shows the Source Current, Load Current, Inverter Injecting Current, and Grid Voltage of Proposed 4-Leg VSI with Balanced Non Linear Load Condition, due to non linear load our source parameters distorts, but compensator compensates the harmonics and maintain sinusoidal nature.

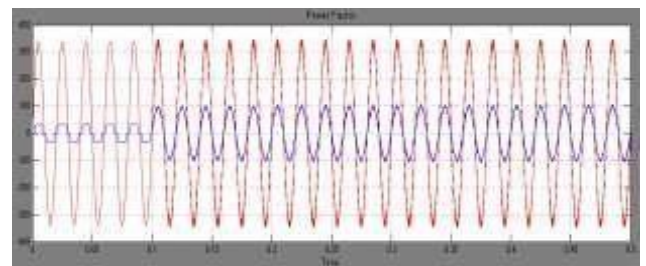

Figure 15: Power Factor

Fig.15 shows the Power Factor of Proposed 4-Leg VSI with Balanced Non Linear Load Condition.

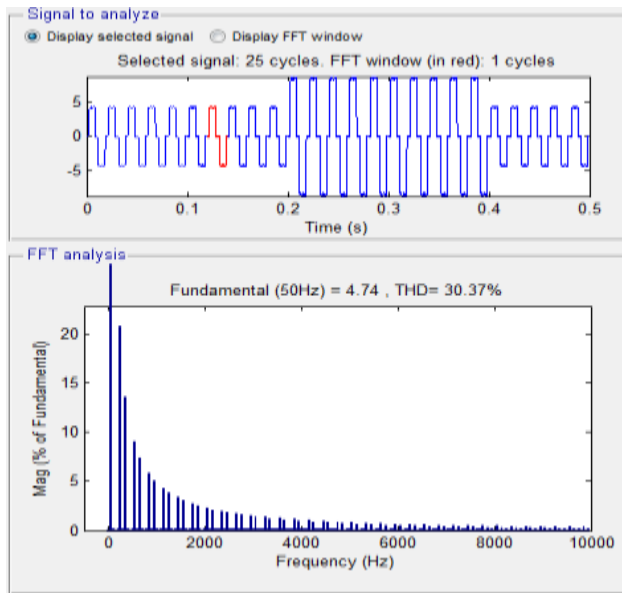

Figure 16: FFT Analysis of Source Current of Proposed 4- Leg without VSI with Balanced Non Linear Load Condition

Fig.16 shows the FFT Analysis of Source Current of Proposed 4-Leg without VSI with Balanced Non Linear LoadCondition, we get 30.37%.

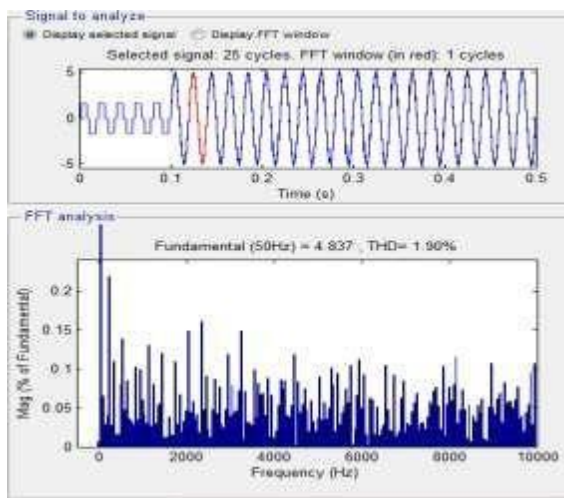

Figure 17: FFT Analysis of Source Current of Proposed 4-Leg with VSI with Balanced Non Linear Load Condition

Fig.17 shows the FFT Analysis of Source Current of Proposed 4-Leg with VSI with Balanced Non Linear Load Condition, we get 1.90%.

Case 4: Implementation of 4-Leg VSI with Un-Balanced Non Linear Load Condition.

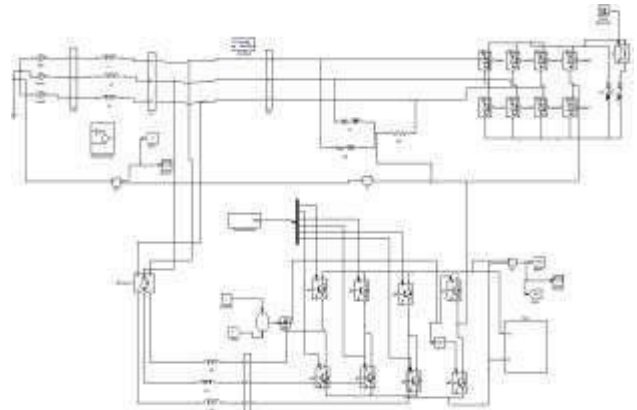

Figure 18: Matlab/Simulink Model of Proposed 4-Leg VSI with Un-Balanced Non Linear Load Condition

Fig.18 shows the Matlab/Simulink Model of Proposed 4-Leg VSI with Un-Balanced Non Linear Load Condition using Matlab/Simulink Platform.

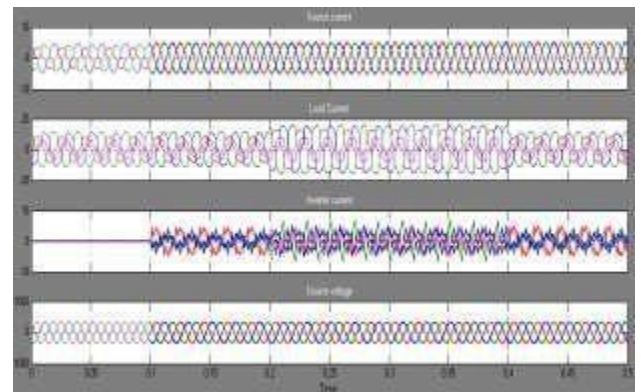

Figure 19: Source Current, Load Current, Inverter Injecting Current, Grid Voltage

Fig.19 shows the Source Current, Load Current, Inverter Injecting Current, and Grid Voltage of Proposed 4-Leg VSI with Un-Balanced Non Linear Load Condition, due to unwanted impedance based non linear load our source parameters distorts, but compensator compensates the harmonics and maintain sinusoidal nature.

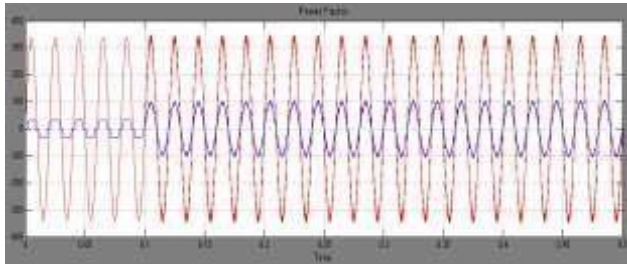

Figure 20: Power Factor

Fig.20 shows the Power Factor of Proposed 4-Leg VSI with Un-Balanced Non Linear Load Condition.

Case 5: Implementation of 4-Leg VSI with Un-Balanced Variable Non Linear Load Condition

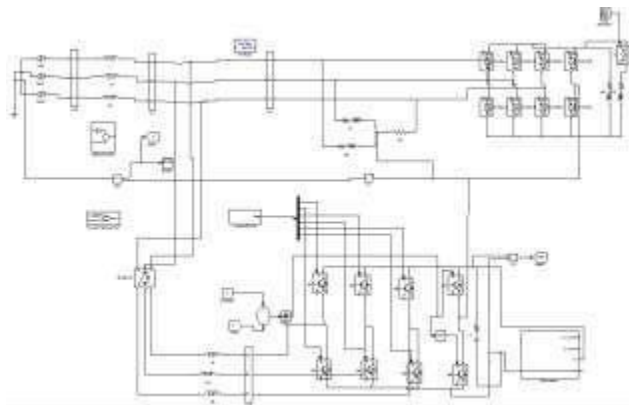

Figure 21: Matlab/Simulink Model of Proposed 4-Leg VSI with Un-Balanced variable Non Linear Load Condition

Fig.21 shows the Matlab/Simulink Model of Proposed 4-Leg VSI with Un-Balanced variable Non Linear Load Condition using Matlab/Simulink Platform.

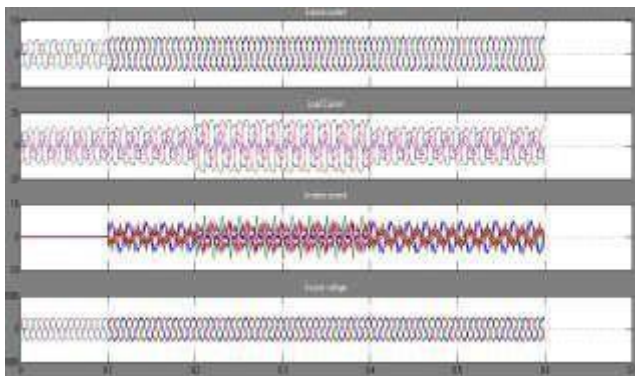

Figure 22: Source Current, Load Current, Inverter Injecting Current, Grid Voltage

Fig.22 shows the Source Current, Load Current, Inverter Injecting Current, and Grid Voltage of Proposed 4-Leg VSI with Un-Balanced variable Non Linear Load Condition, due to unwanted impedance based non linear load our source parameters distorts, but compensator compensates the harmonics and maintain sinusoidal nature.

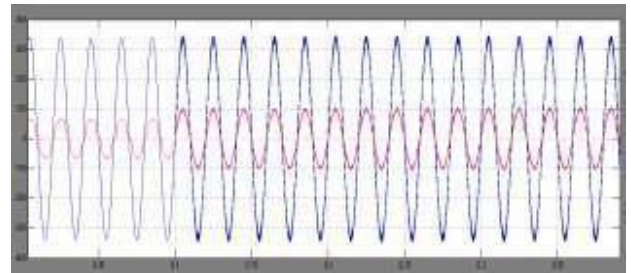

Figure 23: Power Factor

Fig.23 shows the Power Factor of Proposed 4-Leg VSI with Un-Balanced variable Non Linear Load Condition.

5. Conclusion

As conventional fossil-fuel energy sources diminish and the world's environmental concern about acid deposition and global warming increases, renewable energy sources (solar, wind, tidal, and geothermal, etc.) are attracting more attention as alternative energy sources. This paper presented a control of Three phase Four leg grid interfacing inverter improve the quality of power at PCC for a 3 phase 4 wire system applied to various load conditions, here we preferred balanced as well as unbalanced load conditions with linear & non-linear load. It has been shown that the grid interfacing inverter can simultaneously be utilized to inject power generated from RES to PCC and to improve the quality of power at PCC. Thus the proposed controller precisely manages any variation in real power at dc link and effectively feeds it to the main grid. The current harmonics caused by non linear load connected at PCC are compensated effectively such that the grid currents are always maintained sinusoidal at unity power factor. This approach thus eliminates the need for additional power conditioning equipment to improve the quality of power at PCC. Thus the load neutral current is prevented from flowing into the grid side by compensating it locally from the fourth leg of the inverter.

References

- [1] J. M. Guerrero, L. G. de Vicuna, J. Matas, M. Castilla, and J. Miret, "A wireless controller to enhance dynamic performance of parallel inverters in distributed generation systems," *IEEE Trans. Power Electron.*, vol. 19, no. 5, pp. 1205–1213, Sep. 2004.
- [2] J. H. R. Enslin and P. J. M. Heskes, "Harmonic interaction between a large number of distributed power inverters and the distribution network," *IEEE Trans. Power Electron.* vol. 19, no. 6, pp. 1586–1593, Nov. 2004.
- [3] U. Borup, F. Blaabjerg, and P. N. Enjeti, "Sharing of nonlinear load in parallel-connected three-phase converters," *IEEE Trans. Ind. Appl.*, vol. 37, no. 6, pp. 1817–1823, Nov./Dec. 2001.
- [4] P. Jintakosonwit, H. Fujita, H. Akagi, and S. Ogasawara, "Implementation and performance of cooperative control of shunt active filters for harmonic damping throughout a power distribution system," *IEEE Trans. Ind. Appl.*, vol. 39, no. 2, pp. 556–564, Mar./Apr. 2003.
- [5] G. Satyanarayana., K.N.V Prasad, G.Ranjith Kumar, K. Lakshmi Ganesh, "Improvement of power quality by using hybrid fuzzy controlled based IPQC at various load conditions," *Energy Efficient Technologies for Sustainability (ICEETS), 2013 International Conference on* , vol., no., pp.1243,1250, 10-12 April 2013.
- [6] F. Blaabjerg, R. Teodorescu, M. Liserre, and A. V. Timbus, "Overview of control and grid synchronization for distributed power generation systems," *IEEE Trans. Ind. Electron.*, vol. 53, no. 5, pp. 1398–1409, Oct. 2006.
- [7] J. M. Carrasco, L. G. Franquelo, J. T. Bialasiewicz, E. Galván, R. C. P. Guisado, M. Á. M. Prats, J. I. León, and N. M. Alfonso, "Power electronic systems for the grid integration of renewable energy sources: A survey," *IEEE Trans. Ind. Electron.*, vol. 53, no. 4, pp. 1002–1016, Aug. 2006.
- [8] G. Satyanarayana., K.N.V Prasad, G.Ranjith Kumar, K. Lakshmi Ganesh, "Improvement of power quality by using hybrid fuzzy controlled based IPQC at various load conditions," *Energy Efficient Technologies for Sustainability (ICEETS), 2013 International Conference on* , vol., no., pp.1243,1250, 10-12 April 2013.
- [9] V. Khadkikar, A. Chandra, A. O. Barry, and T. D. Nguyen, "Application of UPQC to protect a sensitive load on a polluted distribution network," in *Proc. Annu. Conf. IEEE Power Eng. Soc. Gen. Meeting*, 2006, pp. 867–872.
- [10] G. Satya Narayana, Ch. Narendra Kumar, Ch. Rambabu "A Comparative Analysis of PI Controller and Fuzzy Logic Controller for Hybrid Active Power Filter Using Dual Instantaneous Power Theory" *International Journal of Engineering Research & Development*, Vol-4, Issue- 6, p.p. 29-39, Oct, 2012.
- [11] P. Rodríguez, J. Pou, J. Bergas, J. I. Candela, R. P. Burgos, and D. Boroyevich, "Decoupled double synchronous reference frame PLL for power converters control," *IEEE Trans. Power Electron.*, vol. 22, no. 2, pp.584–592, Mar. 2007.