

# Bluetooth Gesture Controlled Surveillance Robot

Preethi S<sup>1</sup>, Sangeetha N<sup>2</sup>, Manoj N<sup>3</sup>, Dr. Shamala N<sup>4</sup>

<sup>1</sup>Student, 4VM18EE058, Vidya Vikas Institute of Engineering and Technology, Mysuru

<sup>2</sup>Student, 4VM19EE036, Vidya Vikas Institute of Engineering and Technology, Mysuru

<sup>3</sup>Student, 4VM18EE427, Vidya Vikas Institute of Engineering and Technology, Mysuru

<sup>4</sup>Professor and HOD, Department of EEE, Vikas Institute of Engineering and Technology, Mysuru

\*\*\*

**Abstract** - A unique and cutting-edge technology created to further the area of surveillance robots is the Bluetooth Gesture Controlled Surveillance Robot. In this research, a robotic system that can be operated remotely through Bluetooth utilising hand gestures is introduced. Hand gestures may replace complicated interfaces or physical controllers, simplifying the control process and making it more user-friendly. The surveillance robot can manoeuvre and gather visual data in real-time thanks to a variety of sensors and a wireless camera. The operator may see the surroundings from a secure distance thanks to the wireless transmission of the recorded video to a distant device. Machine learning methods are used to create the gesture recognition system, which enables the robot to precisely understand and react to certain hand gestures. The Bluetooth Gesture Controlled Surveillance Robot that is being presented has several benefits, including expanded accessibility, improved manoeuvrability, and improved user experience. Applications for this technology may be found in many fields, such as security, law enforcement, and operations involving surveillance in dangerous situations.

**Key Words:** Bluetooth Gesture Controlled Surveillance Robot, surveillance, manoeuvre, Machine learning, manoeuvrability

## 1. INTRODUCTION

In recent years, Bluetooth gesture-controlled surveillance robots have grown in popularity. In a variety of situations, including homes, businesses, and public spaces, these robots are intended to provide improved security and surveillance capabilities. Typically, these robots are furnished with a variety of sensors, cameras, and other gadgets that enable them to recognize and react to their environment. They may also be operated remotely using a Bluetooth-enabled tablet, laptop, smartphone app, or other Bluetooth-enabled device.

These robots' gesture control function is quite creative. Users may guide the robot's motions using simple hand gestures, making navigation, and directing it to specified locations simpler. While users need to keep their hands free, such as while carrying other equipment or doing other duties, this function is very helpful.

The adaptability of Bluetooth gesture-controlled surveillance robots is one of their main advantages. They may be used for a variety of tasks, such as monitoring, checking, and surveillance. They may be programmed to take certain routes or exhibit certain behaviors, or to react to circumstances or triggers. The simplicity of the operation of these robots is another important advantage. Users may rapidly master robot control because of the gesture control interface's simplicity and clarity. As a result, they are excellent for usage in circumstances where users do not have substantial technical expertise or training. Despite all of its advantages, Bluetooth gesture-controlled surveillance robots have significant drawbacks. Keeping the gadgets and the data they gather secure is one of the major difficulties. As these robots develop in sophistication, hackers and other bad actors may use them as a target. Despite all of its advantages, Bluetooth gesture-controlled surveillance robots have significant drawbacks. Keeping the gadgets and the data they gather secure is one of the major difficulties. As these robots develop in sophistication, hackers and other bad actors may use them as a target.

Manufacturers of Bluetooth gesture-controlled surveillance robots must put robust security mechanisms in place, such encryption and multi-factor authentication, to reduce these threats. They must also make sure that their gadgets have the most recent software and security fixes on a regular basis.

In terms of robotics and surveillance, Bluetooth gesture-controlled surveillance robots are an intriguing breakthrough. We may anticipate seeing even more cutting-edge features and capabilities added to these gadgets as technology develops, increasing their usefulness in a variety of applications.

## 2. Literature Survey

Many researchers have focused on the development of gesture-controlled robots, and several studies have been conducted on the development of Bluetooth gesture-controlled surveillance robots.

For instance, in a study conducted by M.A. Hossain et al. (2019), a Bluetooth-controlled surveillance robot was designed, which could move in any direction and capture images using a camera mounted on the robot. The

researchers used a Bluetooth module to control the robot's movements and an ultrasonic sensor to avoid obstacles.

In another study conducted by S. Bharathi et al. (2017), a gesture-controlled surveillance robot was designed to move in different directions and capture images. The researchers used a microcontroller to control the robot's movements and a Bluetooth module to receive gesture commands from a smartphone. The robot was also equipped with an infrared sensor to detect obstacles and avoid collisions.

Similarly, in a study conducted by P. Selvamani et al. (2018), a Bluetooth-controlled surveillance robot was designed, which could be controlled using an Android smartphone. The robot was designed to move in different directions and capture images using a camera mounted on the robot. The researchers used a Bluetooth module to receive commands from the smartphone, and a microcontroller to control the robot's movements.

### 3. PROBLEM STATEMENT

- Surveillance robot without proper control options
- No Robot with good accessibility
- No cost-effective system which is reliable

### 4. OBJECTIVES

- Remote Control: The robot may be moved about and directed to certain regions for surveillance via Bluetooth remote control.
- Gesture Recognition: The robot can recognize user-made hand movements and react in accordance, making control simple and straightforward.
- Surveillance: The robot's cameras and sensors enable it to gather and relay data about its surroundings, making it suitable for surveillance operations.
- Navigation: To gather data and photographs, the robot may move across a range of locations, including both indoor and outdoor areas.
- Data Collection: The robot is capable of wirelessly transmitting data and pictures to a distant computer or mobile device while simultaneously collecting data and photographs.
- Security: The robot may be used to improve security in a number of locations, including residences, companies, and public areas.

- Accessibility: Because the robot is simple to use, it is available to a variety of users, including those with impairments.
- Economical: Because the robot can be constructed from inexpensive parts, it is an affordable option for security and surveillance tasks.

### 5. PROPOSED METHODOLOGY AND CIRCUITRY

The project's work is shown in the following flowchart.

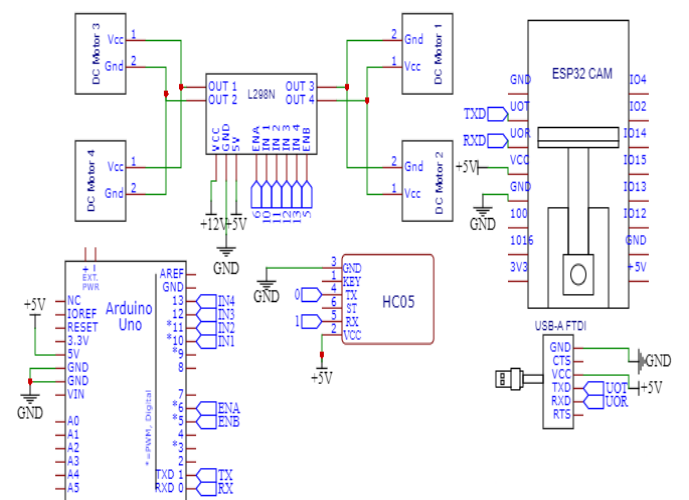
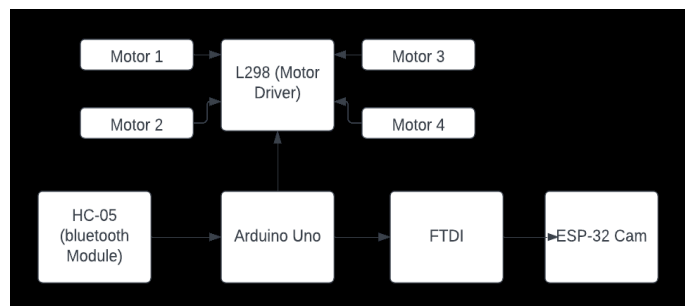

### 6. BENEFITS AND DRAWBACKS

#### Benefits:

- Remote Control: Bluetooth gesture-controlled surveillance robots' key benefit is the ability to be controlled remotely with hand gestures through a Bluetooth connection. This makes it possible for the operator to operate the robot without having to physically engage with it, which is very beneficial in risky or dangerous circumstances.
- High-Quality Surveillance: The robot is equipped with sensors and cameras of the highest caliber, enabling it to conduct precise and ongoing surveillance. This makes it

the perfect tool for security officers who need to remotely monitor vast regions.

- Versatile: Bluetooth gesture-controlled surveillance robots can operate in a wide range of settings, including factories, warehouses, airports, and other public spaces.
- Relatively affordable compared to other forms of surveillance technology, Bluetooth gesture-controlled surveillance robots are a desirable solution for companies and organizations with tight budgets.

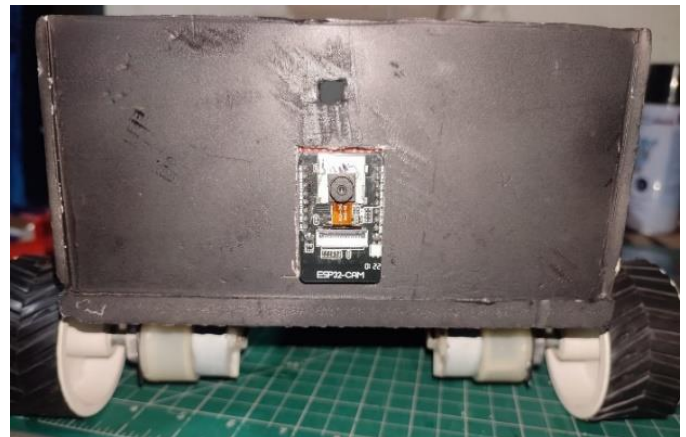

### Drawbacks

- Bluetooth gesture-controlled surveillance robots' low range is one of their key limitations. The robot can only be operated within a set range thanks to the 30-metre maximum range of Bluetooth technology.
- Interference: The communication between the robot and the operator may be hampered by Bluetooth technology's susceptibility to interference from other wireless devices. This might result in the robot becoming uncontrollable and jeopardize the security of the region being watched.
- Battery Life: The batteries that power Bluetooth gesture-controlled surveillance robots have a finite lifetime. The robot's battery life influences how long it can run before having to be recharged. If the robot must be operated for extended periods of time, this may be an issue.
- Limited Functionality: Even though Bluetooth gesture-controlled surveillance robots are very adaptable, they nonetheless have significant functional restrictions. For instance, they may not be able to maneuver through certain terrain or settings or carry out specific jobs that need human interaction.

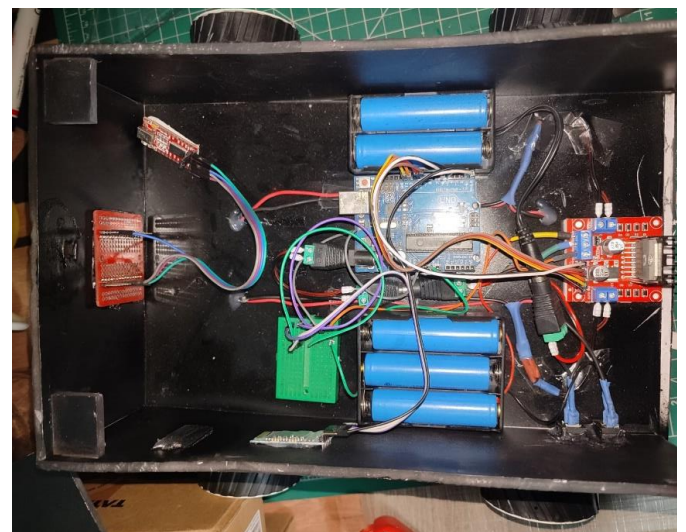

### 7. HARDWARE IMPLEMENTATION

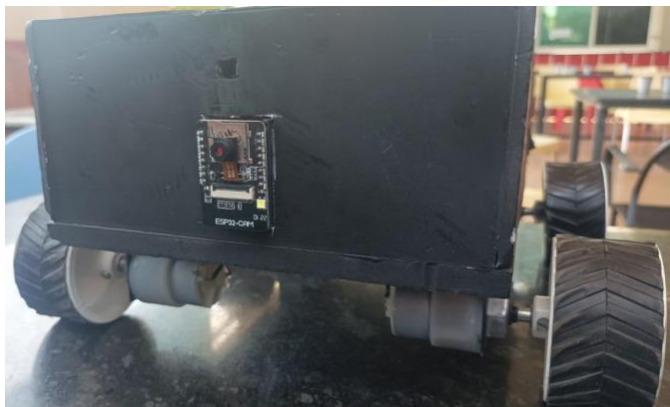

### 8. RESULT

The above-described technique is used for this project. It uses a two-switch arrangement, one of which turns on the main control circuit and the other the motor circuit. The motors are controlled by the Arduino Uno board using a Motor Driver, and mobile device control is made possible using a Bluetooth module. As a surveillance model, an ESP32 Cam module connects to a website to produce real-time video and enable prompt communication over the defined channel. This adaptable surveillance system, which provides dependable monitoring and quick reaction capabilities, may be used in a variety of circumstances where surveillance is necessary.

### 9. APPLICATIONS

- Wherever remote-controlled vehicles are utilized for surveillance and reconnaissance, the Bluetooth Gesture-controlled Surveillance Rover may be deployed. The following are some uses for this technology:

- **Military:** These rovers may be used by the military to conduct surveillance in dangerous settings where human lives are in danger.
- **Law Enforcement:** These rovers may be used by police forces to regulate traffic, control crowds, and keep an eye out for suspicious activity.
- **Industrial Inspection:** These rovers may be employed in manufacturing facilities to check and keep an eye on machinery and procedures that pose a risk to workers.
- **Search and Rescue:** The rovers may be utilized for search and rescue operations in disaster-stricken regions.
- **Agriculture:** Farmers may use these rovers to regulate irrigation, analyze soil, and monitor crops.
- **Wildlife Conservation:** These rovers may be used by wildlife conservationists to follow and monitor animal numbers and behavior in their natural settings.
- **Education:** These rovers may be used in educational facilities for

## 10. CONCLUSION

Finally, Bluetooth gesture-controlled surveillance robots provide a strong and adaptable tool for improving security and surveillance operations. These robots can transmit and gather data in real-time, enabling remote control of their motions and easy hand gesture-based environment monitoring. Due to Bluetooth technology's low cost, more businesses and organizations are now able to use these robots.

These robots offer several benefits, including usability and real-time situation awareness, but they also have drawbacks. It may be difficult to cover huge regions due to the Bluetooth technology's restricted range, which can also limit the operator's control distance. The accuracy of the robot's control signals may also be impacted by interference from other electrical equipment.

Future innovations could include more sophisticated control systems, such Wi-Fi or radio-frequency technology, to expand the range and dependability in order to get over these restrictions. In conclusion, Bluetooth gesture-controlled surveillance robots have enormous potential to enhance security measures in institutional, governmental, military, commercial, and industrial contexts by offering effective and efficient surveillance solutions. The initiative helps to develop a community of recycling plastic.

## REFERENCES

- [1] A. Singh, T. Gupta, and M. Korde, "Bluetooth controlled spy robot," 2017 International Conference on Information, Communication, Instrumentation and Control (ICICIC), Indore, India, 2017, pp. 1-4, doi: 10.1109/ICOMICON.2017.8279135.
- [2] Hasan, A. S., Jewel, M. K. H., Mostakim, M. N., Bhuiyan, N. H., Rahman, M. K., Hossain, S. D., & Hossain, M. K. (2017). Smartphone controlled spy robot with video transmission and object collector. *International Journal of Engineering and Manufacturing (IJEM)*, 7(6), 50-58.
- [3] Suhendar, B., & Hendra, Y. (2020, March). Spy Robot that is Controlled by Bluetooth Android Mobile. In *1st International Multidisciplinary Conference on Education, Technology, and Engineering (IMCETE 2019)* (pp. 37-39). Atlantis Press.
- [4] Bokade, A. U., & Ratnaparkhe, V. R. (2016, April). Video surveillance robot control using smartphone and Raspberry pi. In *2016 International Conference on Communication and Signal Processing (ICCSP)* (pp. 2094-2097). IEEE.
- [5] Infantina, L. R. J., Sherin, L., & Priya, L. R. Hand Gesture Controlled Surveillance Robot using IOT. vol, 2, 488-494.
- [6] Naik, Y. M., Deshpande, C. M., Shah, R. R., & Kulkarni, R. R. (2013). Android Controlled Spy-Robot. *International Journal of Software and Web Sciences*, 4(1), 54-57.