

IoT-based automatic billing and milk quality management system

Prathamesh Jadhav¹, Deepa Bagildavar², Preeti Hiresheedi³, Sunil Huttaganavar⁴,
Lohit Dalal⁵, Shridevi Baragi⁶

¹Student, Dept. of Ece engineering, SGBIT Belagavi, Karnataka, India

²Student, Dept. of Ece engineering, SGBIT Belagavi, Karnataka, India

³Student, Dept. of Ece engineering, SGBIT Belagavi, Karnataka, India

⁴Student, Dept. of Ece engineering, SGBIT Belagavi, Karnataka, India

⁵Professor, Dept. of Ece engineering, SGBIT Belagavi, Karnataka, India

⁶Professor, Dept. of Ece engineering, SGBIT Belagavi, Karnataka, India

Abstract - "IoT-based automatic billing and milk quality management system" is an integrated solution designed to enhance the efficiency and accuracy of milk processing operations. This project focuses on addressing key challenges in the dairy industry by implementing advanced technologies for quality assessment, billing automation, and auto-filling. The system begins with a robust milk quality measurement module, utilizing sensors and data analytics to assess various parameters such as fat content, temperature, and PH. Real-time monitoring ensures that only high-quality milk is processed, contributing to improved product standards and consumer satisfaction. The Auto Billing component of the system automates the billing process by integrating with the milk collection data. This eliminates manual errors, streamlines financial transactions, and provides transparent and traceable billing information for both farmers and processors. The system is designed to generate accurate invoices based on the quality and quantity of milk received from individual farmers, promoting fairness in transactions. In addition, the Auto-filling System optimizes the packaging process by employing automated machinery that efficiently measures and dispenses the appropriate quantity of milk into packaging units. This not only reduces the chances of human errors but also enhances the overall speed and consistency of the filling process. The integration of these three components into a seamless system result in a more streamlined and cost-effective milk processing workflow. The project aims to enhance the overall productivity of dairy farms and processing units, ensuring the delivery of high-quality products to consumers while promoting fair and transparent business practices within the dairy supply chain.

Key words- IoT, Milk quality management, Billing automation, Auto-filling, Dairy industry challenges

1.INTRODUCTION

The dairy industry plays a crucial role in global food production and economy. With advancements in technology, there has been a paradigm shift towards modernizing dairy operations for efficiency, accuracy, and quality assurance.

One such innovation is the IoT-based Automatic Billing and Milk Quality Management System, aimed at revolutionizing the traditional milk collection process. The conventional milk collection process involves manual sampling, testing, and billing, which are labor-intensive, time-consuming, and prone to errors. Moreover, ensuring milk quality and fair pricing for both producers and consumers remains a challenge. The proposed system leverages IoT technology to address these challenges by automating the entire process while enhancing quality control.

The advent of the Internet of Things (IoT) has revolutionized various industries, including agriculture and dairy farming. One such innovative application is the development of an IoT-based automatic billing and milk quality management system. This system integrates IoT technology with traditional dairy farming practices to streamline operations, enhance efficiency, and ensure product quality. At its core, the IoT-based automatic billing and milk quality management system comprises several interconnected components designed to monitor, assess, and manage crucial parameters related to milk production and billing processes. These components include sensors for measuring fat content, pH levels, and temperature of the milk, as well as mechanisms for auto-filling containers and generating automated bills.

The IoT-based system consists of sensor nodes installed at milk collection points, processing units, and billing terminals. These nodes are equipped with sensors for measuring key parameters such as fat content, pH level, and temperature of the milk. The data collected by these sensors are transmitted wirelessly to a central processing unit where they are analyzed in real-time. The fat content measurement is particularly crucial as it directly impacts the grade and market value of the milk. Fat Measurement: Accurate measurement of fat content in milk is essential for determining its quality and value. The system employs specialized sensors or techniques such as ultrasonic or near-infrared spectroscopy to precisely measure the fat content.

Based on the measured parameters, the system automatically grades the milk quality and calculates the appropriate billing amount. Auto-filling mechanisms are

employed to streamline the collection process, ensuring accurate quantity measurement and reducing spillage or wastage. Auto billing functionality enables seamless and transparent transactions between dairy farmers and collection centers, eliminating manual invoicing errors and disputes. One of the key features of the system is its ability to generate automated bills based on the grade of the milk calculated from the measurements obtained by the sensors. The grade is determined by factors such as fat content, pH levels, and temperature, which are indicative of the milk's quality. By automating the billing process, the system eliminates the need for manual invoicing, thereby saving time and reducing administrative overhead.

1.1 Background

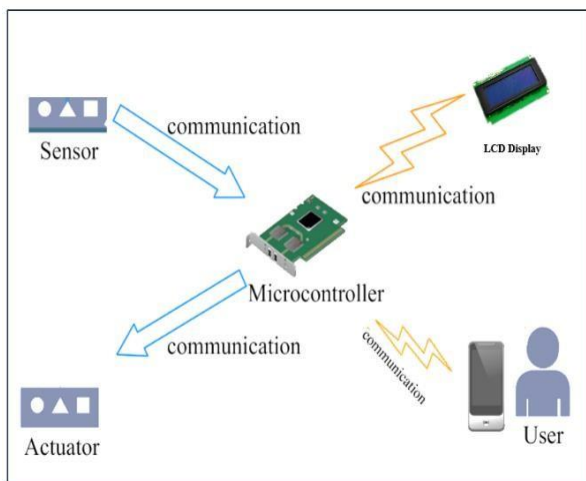

Fig. 1.1.1 Microcontroller Ecosystem

An IoT system is a network of devices that collect and share data. The block diagram shows the basic components and how they interact. **Sensor:** The sensor is used to detect or measure a physical characteristic of the environment, such as temperature, light, or motion. **Microcontroller:** The microcontroller is the brain of the system. It receives data from the sensor, processes it, and then sends instructions to the actuator. **Actuator:** The actuator is a device that takes action based on the instructions from the microcontroller. For example, it might turn on an LED, open a valve, or sound a buzzer. **LCD Display:** The LCD display shows information about the system, such as sensor readings or actuator status. **Communication:** The communication arrows show how the different components communicate with each other. The wireless communication system allows the devices to communicate with each other without wires.

2. METHODOLOGY

The core of the IoT-based automatic billing and milk quality management system is structured around several key components: sensors PH, temperature, load cell, and fat sensor, a central processing unit Arduino Mega with

ATMEGA328 microcontroller, a flow management module pump and flow sensor, and an IoT communication module (NodeMCU board). Each of these components plays a crucial role in the seamless operation of the system, working in tandem to measure, analyze, process, and communicate milk quality and quantity data.

Microcontroller Unit (MCU) - Arduino Mega

At the heart of the system lies the Arduino Mega, which is equipped with the ATMEGA328 microcontroller. This unit is responsible for:

- Receiving data from various sensors.
- Processing this data to determine milk quality parameters such as pH, temperature, fat content, and volume.
- Calculating the grade and price of the milk based on predefined criteria and algorithms.
- Managing user inputs and outputs through a user interface.
- Controlling peripheral devices like pumps and sensors based on user requests and sensor data.

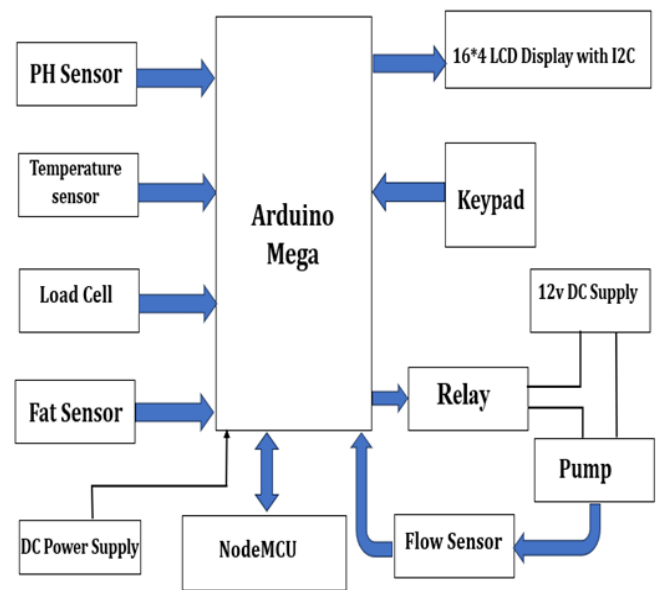

Fig. 2.1 Block Diagram of The Proposed Method

The Flow chart of this proposed depicts the process of milk quality management that uses IoT (Internet of Things) to enhance efficiency.

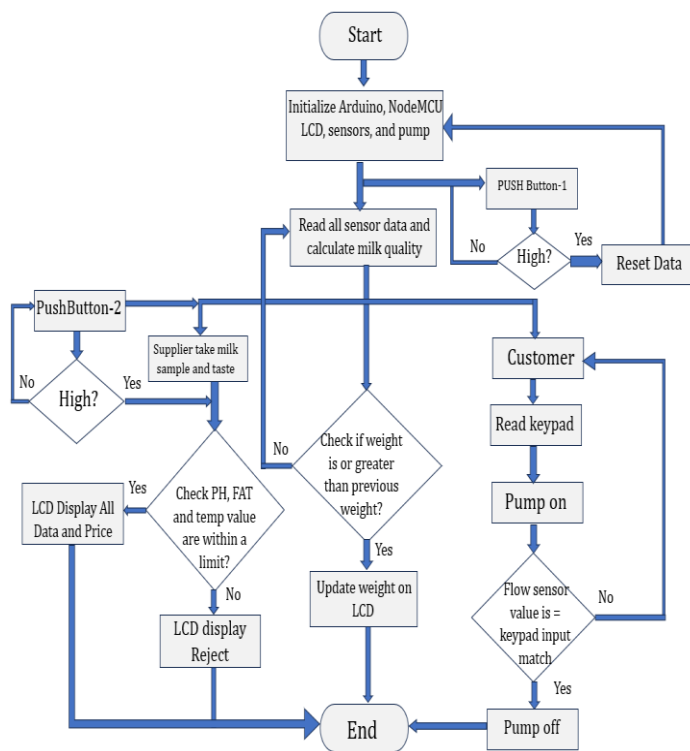

Fig. 2.2 Flow chart of the proposed System

Initial Display: The system powers up and displays "Milk Quality Management System" on the LCD.

Check Stock: The system checks if there is stock (milk) on the weight sensor.

- If stock is present, it displays the stock value.
- If no stock is detected, it continues to display "Milk Quality Management System".

User Action - Calculate:

- If the user presses the 'Calculate' button, the system proceeds to gather input from various sensors (like temperature, fat content, etc.).
- The milk parameters and price are then calculated based on these inputs and displayed on the LCD. If the 'Calculate' button is not pressed, the system continues to display the stock value.

User Action - Reset:

If the user presses the 'Reset' button at this stage, the system returns to the initial display of "Milk Quality Management System". If not, the process moves to the next user decision point.

User Sale Input:

The user inputs the desired amount of milk to sell to the customer via a keypad.

If the '#' key is pressed, the pump starts and the milk dispensing begins.

If the '#' key is not pressed, the system prompts for correct inputs until it is provided.

Pumping and Monitoring:

While the pump is active, the flow sensor continuously monitors the milk flow.

If an out-of-range flow is detected, the pump is stopped.

If the flow is within the acceptable range, the pumping continues.

Final User Action - Reset:

If during or after the sale, the user presses the 'Reset' button, the system returns to the initial display "Milk Quality Management System".

If the 'Reset' button is not pressed after the transaction is completed, the system ends the current operation cycle, ready for a new one.

This flow chart ensures that the milk quality management system operates efficiently, handling stock checks, user inputs, and sales transactions systematically while continuously monitoring and adjusting based on user interactions and sensor data.

2.1 System Operation

1. Data Acquisition: Sensors continuously monitor and gather data on milk parameters.
2. Data Processing: The Arduino Mega analyzes sensor data to determine milk quality and calculate pricing
3. User Interaction: Through a user interface, the seller can input the desired amount of milk to sell, which triggers the system to dispense milk using the pump and measure the amount using the flow sensor.
4. Data Communication: The NodeMCU transmits all relevant data to a cloud server or local host, allowing for real-time tracking and management.
5. Automatic Billing: Based on the quality and quantity of milk dispensed, the system automatically calculates the cost, which can be instantly communicated to the customer and processed for transaction.

The proposed IoT-based system automates critical aspects of milk quality management and billing, providing a scalable, efficient, and user-friendly solution for dairy businesses. By integrating advanced sensors, robust processing capabilities, and IoT connectivity, the system ensures high-quality dairy products reach consumers in an economically efficient manner. Future enhancements may include integration with blockchain for secure transactions and expanded analytics for predictive maintenance and supply chain optimization. This detailed block diagram methodology not only illustrates the interconnectivity of the components but also underscores the practical impact of IoT in modern agricultural practices.

3.SUMMARY

The "IoT-Based automatic billing and Milk Quality Management system" marks a significant advancement in the dairy industry, addressing various long-standing challenges through the application of the Internet of Things. This comprehensive solution integrates state-of-the-art technologies to enhance the quality control, billing, and filling processes in the dairy supply chain, ensuring a seamless flow from farm to consumer. Enhancing Milk Quality with IoT Sensors: At the core of this innovative system are IoT-enabled quality sensors strategically deployed at critical points in the supply chain. These sensors perform real-time analysis of the milk to detect parameters such as temperature, pH levels, and bacterial content. This immediate data capture ensures that any deviation from established quality standards is quickly identified, allowing for prompt action to rectify any issues, thereby maintaining the integrity and safety of the milk. Auto-Billing Module: The auto-billing module is a critical component of this system. It utilizes the data from IoT sensors to accurately calculate charges based on the quality and quantity of milk delivered. This automation ensures transparency and fairness in billing, reducing errors associated with manual entry and helping to build trust between dairy farmers and processors, as well as between processors and retailers. Energy and Resource Efficiency: The IoT system optimizes the use of energy and resources across the dairy processing chain. By aligning energy usage and resource allocation with actual production needs, the system reduces excess consumption and minimizes waste. This not only lowers operational costs but also contributes to the environmental goals of the dairy industry. Transparency and Traceability: Every step of the milk's journey from the farm to the consumer is recorded and monitored through the IoT system. This level of traceability is invaluable for consumer confidence and regulatory compliance. Consumers increasingly demand transparency in the food supply chain, and this system provides it by offering detailed information about the product's origin, handling, and quality.

Impact on the Dairy Supply Chain: By integrating these technologies, the system transforms the entire dairy supply chain. It enhances efficiency and transparency, reduces waste, and improves product quality. These improvements

can lead to better market competitiveness for dairy businesses and higher satisfaction for consumers.

4.RESULTS AND DISCUSSION

The results and discussion sections provide insights into the data collected during the experimentation phase of the project and elaborate on their implications in the context of the IoT-based automatic billing and milk quality management system.

Measurement of Milk Weight

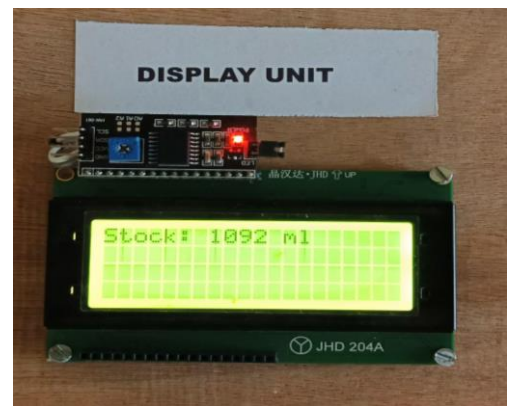

Fig. 4.1 Measurement of Milk Weight

The system accurately measured the weight of the milk using a load cell, providing output displayed on the LCD as stock value. This real-time feedback on the milk's weight allowed for efficient inventory management and ensured that the milk supply could be closely monitored. Through multiple tests and calibration of the load cell, the system consistently provided precise readings. This reliability is essential for maintaining a smooth workflow and avoiding discrepancies in billing or inventory control.

PH Value and Temperature Monitoring

The PH sensor and temperature sensor provided essential data on the quality of the milk. The PH value indicates the milk's acidity, which is an important factor in determining freshness and suitability for consumption. The temperature sensor ensured that the milk was stored at an appropriate temperature to preserve its quality. The system effectively tracked these parameters and displayed them on the LCD, allowing for immediate assessment and decision-making. This comprehensive monitoring of PH and temperature helped in adhering to quality standards and regulatory requirements.



Fig. 4.2 PH Value and Temperature Monitoring

Dispensing of Milk

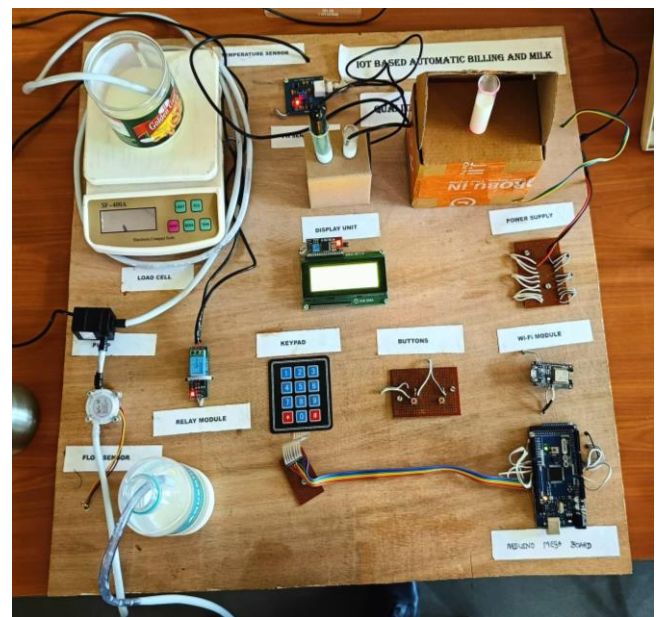

Fig. 4.4 Dispensing of Milk

Price Calculation



Fig.4.3 Price Calculation

A pricing table was created based on the values of PH, fat content, and temperature. This table was designed to account for variations in milk quality and ensure fair and dynamic pricing for the consumer. By using the system's data on milk quality, the pricing table could adjust prices in real-time to reflect changes in the milk's characteristics. This dynamic pricing strategy is beneficial for both the seller and the buyer, as it ensures the sale price matches the milk's quality.

The system was equipped with a flow sensor to dispense milk according to the user's requirements. The flow sensor measured the quantity of milk dispensed, ensuring that the exact amount requested by the customer was delivered. When the desired amount was dispensed, the pump would automatically turn off, preventing any overflow or wastage. This level of precision in dispensing not only improved customer satisfaction but also helped in accurately billing customers based on the volume of milk purchased.

5. CONCLUSION

IoT-Based Automatic Billing and Milk Quality Management System We have developed a comprehensive solution that addresses key aspects of milk production, quality assessment, and distribution. This project integrates several components, including load cells, pH sensors, temperature sensors, and a custom-designed milk fat sensor, to accurately measure and monitor various properties of the milk. The data collected from these sensors is displayed on an LCD screen for easy visualization and monitoring. The project also includes an automatic billing and dispensing system that allows users to enter the desired amount of milk they wish to sell to customers. The system then dispenses the specified amount of milk and calculates the price based on the milk's parameters, such as weight, pH value, temperature, and fat content. The integration of IoT technology in this project enhances the efficiency and reliability of milk production and distribution processes. By automating the measurement and monitoring of milk properties, the system reduces the likelihood of human error and ensures that the milk meets quality standards. This contributes to customer satisfaction and builds trust in the milk's quality. The project also

highlights the importance of real-time data visualization and decision-making. The ability to quickly assess and respond to changes in milk quality and quantity allows producers to optimize their operations and maintain consistent quality. Furthermore, the project demonstrates the potential for IoT technology to revolutionize traditional industries by providing innovative solutions that improve productivity, quality control, and customer service

In conclusion, IoT Based Automatic Billing and Milk Quality Management System is a significant achievement that showcases the potential of integrating advanced technology into the dairy industry. By providing accurate measurements, efficient billing, and quality control, the system contributes to a more streamlined and effective approach to milk production and distribution. This project paves the way for further innovations in the field and serves as a model for other industries seeking to adopt IoT solutions.

REFERENCES

- [1] Dr G Rajakumar, Dr T Ananth Kumar, Dr TS Arun Samuel, Dr E Muthu Kumaran, "IoT Based Milk Monitoring System for Detection of Milk Adulteration", IJPAM, 2018.
- [2] Sumitra Goswami, Ashok Dangi, "Arduino-Based Milk Quality Monitoring System", International Journal of Agriculture Environment & Biotechnology, Volume 14, Issue 2, IJAEB, 2021.
- [3] M Sujatha, P Nagarjuna, A Hemanth Venkata, "Visible spectroscopy analysis of fat content in milk using LabVIEW", International Journal of Recent Technology and Engineering Volume-7, Issue 5S4, IJRTE, 2019.
- [4] Manisa Rathi A. and Raveesh SJ Proposed a "Automated Milk Quality Analyzer with Billing System" in the International Journal of Environment, Agriculture and Biotechnology in 2022
- [5] Prof. Dipti S. Bhade¹, Shradha J. Dobariya, Sanchita S. Landge, Prachi D. Babhale, Veebha M. Proposed a "Implementation Of Iot Based Milk Quality Analyzer Using AVR Microcontroller" in the JETIR May 2019.
- [6] Sanya Kaunkid, Apinan Aurasopon, and Anut Chantiratiku Proposed a "Automatic Milk Quantity Recording System for Small-Scale Dairy Farms Based on Internet of Things"
- [7] V.Hema,, N. Monishkumar, N. Nandhakumar, B. Narmadha Proposed a "Iot Based Milk Monitoring System For Detection Of Milk Quality Using Sensor" in IJCRT 2020.
- [8] Dhamale Avinash, Game Avinash, Kandekar Kiran, Prof. RG Dabhade, "Milk Analyzing and Billing System", Vol 2, Issue 2, IJARIE, 2016.
- [9]. Cristian Piras, Oliver J Hale, Christopher K Reynolds, AK Jones, Nick Taylor, Michael Morris, Rainer Cramer, "Speciation and milk adulteration analysis by rapid ambient liquid MALDI mass spectrometry profiling using machine learning", Biotechnology and Biological Sciences Research Council, 2020.