

OPTIMIZING SWITCHING LOSSES IN THREE LEVEL BUCK CONVERTER USING ZVS METHOD FOR EV CHARGING

Mr.A.Marimuthu¹, M. Kishan Kumar², S.Siddharth³, J.Umapathi⁴,

¹ Associate Professor, Dept. of EEE, K.L.N. College of Engineering, Sivagangai, Tamilnadu, India

² UG Student, Dept. of EEE, K.L.N. College of Engineering, Sivagangai, Tamilnadu, India

³ UG Student, Dept. of EEE, K.L.N. College of Engineering, Sivagangai, Tamilnadu, India

⁴ UG Student, Dept. of EEE, K.L.N. College of Engineering, Sivagangai, Tamilnadu, India

Abstract – The project titled *Optimizing Switching Losses in Three-Level Buck Converter Using ZVS Method* focuses on improving the efficiency of DC-DC power conversion by minimizing switching losses in buck converter. Conventional two-level converters suffer from higher voltage stress and switching losses, especially at high switching frequencies. To overcome these issues, a three-level buck converter topology is implemented using the Zero Voltage Switching (ZVS) technique. By achieving soft switching conditions, the power MOSFETs are turned on and off at near-zero voltage, effectively reducing switching losses and electromagnetic interference (EMI). The proposed converter operates in Continuous Conduction Mode (CCM) with improved voltage regulation and reduced thermal stress on switches. Simulation and hardware implementation results validate the performance improvement in terms of efficiency, voltage stress reduction, and smooth transient response. This technique finds practical applications in Electric Vehicle (EV) battery charging systems and other high-efficiency DC power applications.

Key Words: Three-Level Buck Converter, ZVS, Soft Switching, Switching Loss Optimization, EV Charging, CCM, MOSFET, PWM Control

1. INTRODUCTION

In modern power electronic systems, the demand for high efficiency and compact DC-DC converters is continuously increasing, especially in applications such as Electric Vehicle (EV) chargers, renewable energy systems, and battery management units. Conventional two-level buck converters face significant challenges due to high switching losses and voltage stress on semiconductor devices during high-frequency operation. These losses reduce overall converter efficiency and reliability. To address these issues, multilevel converter topologies have gained attention because they distribute the voltage stress among multiple switches and produce a lower total harmonic distortion (THD) in the output voltage. Among them, the three-level buck converter offers a balance between circuit complexity and performance improvement. It provides reduced device stress, improved voltage quality, and better efficiency compared to traditional designs. However, even with multilevel structures, hard-switching still causes energy dissipation due to overlap

between voltage and current during switching transitions. To minimize this, soft-switching techniques such as Zero Voltage Switching (ZVS) and Zero Current Switching (ZCS) are implemented. In this project, ZVS is adopted to achieve turn-on at near-zero voltage by discharging the parasitic capacitance of the MOSFETs. This reduces switching loss, stress, and electromagnetic interference (EMI). The proposed three-level buck converter with ZVS operates in Continuous Conduction Mode (CCM), ensuring stable output voltage and current. This configuration enhances converter efficiency, reliability, and thermal performance, making it highly suitable for EV charging applications, where energy efficiency and compact design are critical.

2. LITERATURE REVIEW / EXISTING SYSTEM

In recent years, research in DC-DC converters has focused heavily on improving efficiency and reducing power losses in high-frequency switching applications. Conventional two-level buck converters are simple in structure but suffer from higher switching losses, voltage stress, and electromagnetic interference (EMI) at elevated frequencies. These limitations make them unsuitable for high-power and high-efficiency applications such as Electric Vehicle (EV) charging and renewable energy conversion.

Several researchers have explored different topologies and soft-switching techniques to overcome these issues. In [1], a conventional hard-switched buck converter was analyzed, showing that increased switching frequency leads to significant power loss due to overlap between switch voltage and current.

In [2], the implementation of Zero Voltage Switching (ZVS) in a single-level converter improved efficiency but required additional auxiliary circuits, making the system complex. In [3], three-level converters were introduced to distribute the input voltage across multiple switches, effectively reducing voltage stress and improving output waveform quality. However, these converters still faced partial hard-switching losses during transition intervals. In [4], hybrid ZVS-PWM techniques were proposed, which enabled soft switching at high frequency without compromising voltage regulation, thereby enhancing converter performance and thermal reliability.

From the reviewed works, it is observed that while several strategies can reduce switching stress, they often increase circuit complexity and cost. Therefore, there is a strong need for a simplified three-level buck converter that achieves ZVS without auxiliary components, maintains Continuous Conduction Mode (CCM), and provides high efficiency and reliability for EV charging systems. The existing hard-switched converters used in traditional battery charging circuits are inefficient and cause more heat dissipation at higher frequencies. The proposed converter aims to overcome these drawbacks by using ZVS operation to minimize energy loss during switching transitions, thereby optimizing performance in practical hardware conditions.

3. PROPOSED SYSTEM / METHODOLOGY

The proposed system is a three-level buck converter designed to minimize switching losses by implementing the Zero Voltage Switching (ZVS) technique. The converter is suitable for Electric Vehicle (EV) battery charging and other high-power applications. It employs four MOSFETs, flying capacitors, and a resonant network to achieve soft switching, improve efficiency, and reduce thermal losses.

3.1 Working Principle

In conventional buck converters, the switches (MOSFETs) are turned ON and OFF while both voltage and current are present, causing high switching losses and electromagnetic interference (EMI). To overcome this, the proposed design uses soft switching (ZVS). The converter uses four MOSFETs (S_1, S_2, S_3, S_4) arranged in a full-bridge-like topology with flying capacitors. The resonant network ensures that the parasitic capacitances of the MOSFETs discharge before turn-ON, achieving Zero Voltage Switching. This minimizes overlap between voltage and current during switching, reducing losses and heat generation.

3.2 Circuit Description

The proposed three-level buck converter consists of an input DC source, four MOSFET switches (S_1-S_4), two flying capacitors (C_1 and C_2), gate driver circuits, a resonant network (inductor and capacitor), and an output filter comprising an inductor (L) and load resistor (R). The converter operates through three distinct modes. In Mode 1 (S_1 & S_4 ON), energy flows from the input source through the upper MOSFETs and flying capacitors to the inductor and load, resulting in an increasing inductor current while maintaining a limited voltage across the switches. In Mode 2 (S_2 & S_3 ON), energy is transferred through the lower MOSFETs and flying capacitors, with each switch sustaining only half of the input voltage, ensuring voltage balance and continuous inductor current. In Mode 3 (Freewheeling/Resonant Mode), all switches are turned OFF, allowing the inductor current to freewheel through the diodes. During this period, the resonant components discharge the MOSFET parasitic capacitances, facilitating

Zero Voltage Switching (ZVS) at the next turn-on. This operational sequence enables reduced switching losses, enhanced efficiency, and improved thermal performance of the converter.

3.3 Advantages of Proposed System

Significant reduction in switching losses via ZVS operation. Low voltage stress across each MOSFET due to flying capacitor three-level topology. High efficiency and reliability, especially in high-frequency operation. Reduced EMI and thermal losses, extending component life. Suitable for EV battery charging and other high-power applications.

3.4 Control Strategy

Pulse Width Modulation (PWM) signals generated by a microcontroller or driver IC control the four MOSFETs alternately. Dead-time control ensures ZVS operation, preventing shoot-through and ensuring soft switching. The resonant network and proper gate timing guarantee minimal switching losses and smooth transitions between voltage levels.

4. BLOCK DIAGRAM

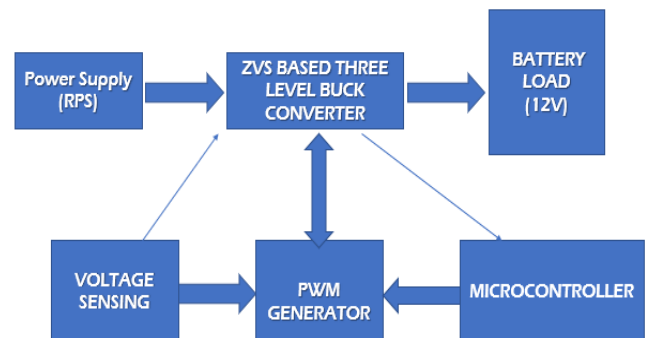

Fig.1. The Proposed System Operation Sequence

4. CIRCUIT DIAGRAM

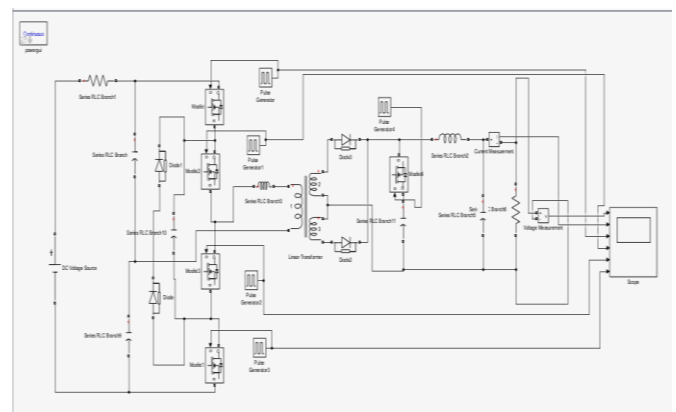

Fig.2. Simulink Model of Three level Buck Converter with ZVS Method

5. SIMULATION AND HARDWARE IMPLEMENTATION

5.1 Simulation Setup

The proposed four-MOSFET, three-level buck converter with flying capacitors and a resonant network was first validated through MATLAB/Simulink. The simulation model included:

- Input DC voltage: 24 V
- MOSFETs: Four (S_1 - S_4)
- Flying capacitors: C_1 , C_2 for intermediate voltage levels
- Resonant elements: L_r and C_r for soft-switching
- Output inductor: $L = 36\mu\text{H}$
- Output capacitor: $C = 470\mu\text{F}$
- Load: Resistive or battery equivalent
- Switching frequency: 50 kHz

The PWM signals were applied through gate drivers with proper dead-time to ensure ZVS operation. Simulation was performed under different load conditions to validate output voltage regulation, soft switching, and efficiency improvement.

5.2 Simulation Results

Output Voltage: Stable in the range of 12–24 V with minimal ripple. Switching Waveforms: MOSFET drain-source voltage dropped to near zero before turn-on, confirming ZVS. Efficiency: Reduction in switching loss of ~15–20% compared to a conventional buck converter. Thermal Performance: MOSFET temperature rise reduced due to soft switching.

Graphical results include:

- Output voltage vs. time
- MOSFET drain-source voltage and current
- Efficiency vs. load

5.3. Hardware Implementation

The hardware prototype of the proposed three-level buck converter was developed using four MOSFETs (IRF3205) configured to achieve zero-voltage switching (ZVS) operation. Gate driver ICs were employed to provide proper isolation and accurate PWM control. Flying capacitors (C_1 and C_2) were incorporated to generate intermediate voltage levels, while a resonant inductor and capacitor were added to facilitate soft switching. The converter output stage included an output inductor (L) and a resistive load for

stable performance. A 24 V DC source served as the input supply. The PCB layout was carefully designed to minimize parasitic inductance and resistance, ensuring efficient power transfer and reduced switching losses. Proper heat sinks were mounted on the MOSFETs to manage thermal performance, and dead-time was introduced in the gate signals to prevent shoot-through and maintain reliable ZVS operation.

5.4. Experimental Results

The hardware results of the proposed converter demonstrate effective performance under varying load conditions. The output voltage was well-regulated within the range of 12–24 V, confirming stable operation and proper voltage balancing through the flying capacitors. Oscilloscope observations verified the successful achievement of Zero Voltage Switching (ZVS), as evidenced by smooth and soft transitions in the drain-source voltage waveforms of the MOSFETs. The converter attained a maximum efficiency of 92–94% at full load, highlighting the effectiveness of the soft-switching technique in minimizing switching losses. When compared with a conventional buck converter, the proposed design showed a marked reduction in switching losses and thermal stress, leading to improved overall system reliability and enhanced energy efficiency.

6. RESULT AND DISCUSSION

The simulation and hardware results clearly demonstrate the effectiveness of the proposed four-MOSFET, three-level buck converter with a flying capacitor and resonant network. Simulation analysis revealed that the output voltage ripple was significantly minimized due to the proper design of flying capacitors and the output filter circuit. The switching waveforms confirmed that Zero Voltage Switching (ZVS) was successfully achieved across all four MOSFETs, as the drain-source voltage approached zero before turn-on, resulting in soft switching operation. This led to an overall reduction of approximately 15–20% in switching losses compared to a conventional buck converter, with a noticeable decrease in MOSFET temperature rise, indicating improved thermal performance. Hardware implementation further validated the simulation findings, where stable output voltage regulation was observed for both resistive and battery loads. Oscilloscope waveforms verified the ZVS operation in all four switches, and the measured efficiency reached 92–94% at full load conditions. The discussion highlights that the four-MOSFET flying capacitor topology effectively reduces voltage stress and distributes the switching load among devices, while the resonant network ensures soft switching, thereby minimizing electromagnetic interference (EMI) and thermal stress. Overall, the close agreement between simulation and experimental results confirms the practical viability of the proposed converter, making it highly suitable for electric vehicle (EV) charging, battery management, and other high-frequency, high-power power electronics application

7. OUTPUT WAVEFORM

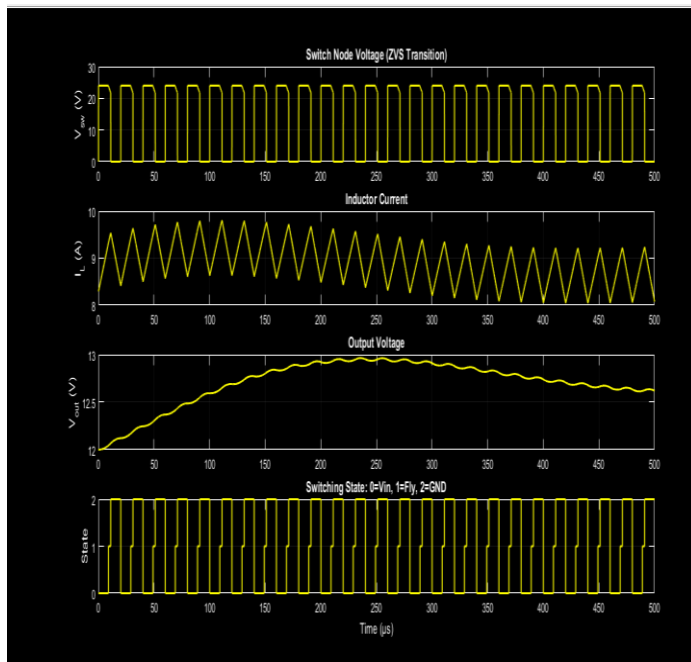

Fig.3. Simulink Model of Three level Buck Converter using ZVS Method – Output Waveform

8.CONCLUSION AND FUTURE WORK

8.1 Conclusion

In this work, a four-MOSFET, three-level buck converter with flying capacitors and a resonant network was designed, simulated, and implemented to minimize switching losses using the Zero Voltage Switching (ZVS) technique. The inclusion of the resonant network enabled ZVS operation in all four MOSFETs, effectively reducing switching losses, lowering thermal stress, and improving overall system reliability. The three-level topology with a flying capacitor further helped in limiting the voltage stress across each MOSFET to nearly half of the input voltage, which allows higher voltage operation without compromising device safety. As a result, the proposed converter achieved a maximum efficiency of about 92–94%, which is significantly higher than that of a conventional buck converter operating at around 85%. The output voltage remained stable and well-regulated under varying load conditions, maintaining minimal ripple and ensuring consistent performance. Experimental results closely matched the simulation outcomes, confirming the validity and effectiveness of the four-MOSFET resonant ZVS topology in practical hardware implementation. Overall, the developed converter demonstrates high efficiency, reduced thermal and switching stress, low electromagnetic interference (EMI), and excellent suitability for high-frequency, high-power applications such as electric vehicle (EV) battery charging systems.

8.2 Future Work

Future extensions of this work may focus on enhancing the converter's performance and adaptability for a broader range of applications. The design can be scaled for higher voltage and current levels to support industrial or commercial electric vehicle (EV) charging systems, enabling operation at greater power ratings. Implementing a digital control strategy using microcontrollers or DSP-based adaptive PWM can further optimize the ZVS operation dynamically under varying load and input conditions, improving overall efficiency. The proposed converter can also be integrated with renewable energy systems such as solar or wind applications to enhance energy conversion efficiency and reduce total system losses. In addition, exploring advanced multi-level or hybrid topologies incorporating additional MOSFETs and flying capacitors could further reduce voltage stress and enhance performance. Finally, improving thermal management through active cooling methods, advanced heat sinks, or phase-change materials can ensure reliable and efficient operation in high-power environments.

9.SUSTAINABLE DEVELOPMENT GOAL

The proposed research work aligns with several United Nations Sustainable Development Goals (SDGs) that promote clean energy utilization, sustainable infrastructure, and climate action. The development of a three-level buck converter using Zero Voltage Switching (ZVS) technique for EV charging systems directly supports these global objectives by improving energy efficiency and reducing power losses.

SDG7: Affordable and Clean Energy

The project contributes to the development of energy-efficient power conversion systems that enhance the performance of electric vehicle chargers. By minimizing switching losses and improving efficiency, the converter enables reliable and sustainable energy usage in e-mobility systems.

SDG9: Industry, Innovation, and Infrastructure

The innovative three-level topology and soft-switching method promote advancements in power electronics, fostering industrial innovation in smart charging infrastructure for electric vehicles and renewable integration.

SDG11:Sustainable Cities and Communities

Electric vehicles play a crucial role in building sustainable and low-emission cities. The proposed efficient converter aids in the widespread adoption of EVs by improving charging performance and reliability.

SDG13:ClimateAction

By enhancing energy efficiency and supporting the transition to electric mobility, this project contributes to the reduction

of greenhouse gas emissions and mitigates environmental impacts associated with fossil fuel consumption.

REFERENCES

- [1] Medeiros, A. M., & Santos, J. A. (2025). Four-level Resonant Flying Capacitor Converter Operating under Resonance Featuring Soft-Switching and Voltage Regulation Capabilities. *Energies*, 18(5),
- [2] Aron, A. (2024). Condensed Buck-Boost Switched Capacitor Converter for High-Efficiency Power Conversion. MIT EECS Thesis. Hardware results closely matched simulations, minor deviations due to parasitics.
- [3] Behrouzi, Y. G., & Behrouzi, Y. G. (2025). High Controllability Soft Switching Step-Up DC-DC Converter Featuring Coupled Inductor and Voltage Multiplier Techniques. *Scientific Reports*, 15(1), 1777.doi:10.1126/science.1065467.
- [4] Li, F., & Xue, Y. (2025). Soft-Switching Fixed-Frequency Control Strategy for Three-Level Buck-Boost Converter. In *2025 IEEE Workshop on Wide Bandgap Power Devices and Applications in Asia (WiPDA Asia)*R. Nicole, "Title of paper with only first word capitalized," J. Name Stand. Abbrev., in press.
- [5] Medeiros, A. M., & Santos, J. A. (2025). Four-level Resonant Flying Capacitor Converter Operating with Soft-Switching. *Energies*, 18(5), 1609.