

Preliminary design and flow simulation on a 6-seater electric vehicle - Case study

Saransh Gupta¹, Arpan Rai², Raj Kushwaha³, Ashutosh Patel⁴, Manish Kumar⁵

¹saransh.gupta.ug21@nsut.ac.in

²arpan.ra.ug21@nsut.ac.in, ³raj.kushwaha.ug21@nsut.ac.in, ⁴ashutosh.patel.ug21@nsut.ac.in

Prof. Manish Kumar ⁵Department of Mechanical Engineering, Netaji Subhas University of Technology (West Campus), New Delhi, India

Abstract - A preliminary study was conducted to explore the design of a six-seater commuter vehicle aimed to be a cost-effective solution for urban residential complex and campus settings. The study focused on developing concepts for tubular chassis design and structural integrity, selecting appropriate electrical and electronic components, and understanding the fundamental mechanisms of the steering system, powertrain, and suspension. Additionally, a basic airflow simulation was performed to visualize the path of air through the vehicle, along with structural tests to assess the chassis performance under heavy loading conditions.

These tests for structural analysis and stress distributions were performed on ANSYS, while the flow simulation was performed on SOLIDWORKS. This study sets the foundation for full-scale prototyping and future iterations of the vehicle design

1. INTRODUCTION

The recent paradigm shift toward the sustainability of energy and its impact on mobility is evident through government policies and shifts in the general population's mindset. The increase in numbers of electric busses and cabs is a live example to this statement. Due to EVs' zero tailpipe emissions, they are well-equipped for public transport. present a unique challenge, Due to absence of large budgets.

1.1 Background

In today's era, designing a cost effective 6 seater vehicle present a unique challenge, Due to absence of large budgets and full-scale wind tunnel testing, simulation techniques become critical. These techniques can be used for optimising vehicles exterior shape and making them safer while minimizing coefficient drag. This would ensure uniform airflow distribution across the body. Uniform flow would also help analyse thermal flow behavior as it would directly impact the battery cooling and cabin ventilation.

Although EV's are very efficient in nature they do have a glaring problem in them. Even the state-of-the-art electric vehicle with modern charging technology and Level 3 charging systems, also known as Fast DC-DC charging systems, take about 8 hours. One commonly overlooked parameter is aerodynamics for a multi seater vehicle. Due to their blocky designs the drag coefficient is significantly higher compared to other 4-seater EV's. This parameter indirectly affects the range of the vehicle further affecting the efficiency of the vehicle. A flow study would ensure uniform airflow distribution across the body. Uniform flow would also help analyze thermal flow behavior as it would directly impact the battery cooling and cabin ventilation.

1.2 Problem Statement

While the global markets seem to be expanded at a large rate than usual for electric vehicles, they are largely for cars and buses. The intermediate category for transit such as electric golf cart remains under-developed. These vehicles have a popular demand in institutional campuses and large residential complex. Hence, there is a need for a simulation-based design approach that can allow engineers to optimize vehicle shape during the preliminary design phase.

1.3 Objective of this study

This study was aimed to explore a viable CAD model for manufacturing and perform preliminary flow simulation to optimize the CAD model further.

- To develop preliminary CAD model of a 6-seater EV.
- To perform external flow simulation using Ansys Discovery
- To simulate loading of chassis for enhanced safety

2. LITERATURE REVIEW

A study on structural analysis of a ladder-frame chassis by Patel et.al. (2012) [1] highlighted the advantages of tubular ladder frame chassis for medium to heavy-weight vehicles. It tells us how tubular frames enhance structural rigidity while reducing weight, a critical factor in electric vehicle design to make it energy efficient. Finite Element Analysis (FEA) was used to assess the frame under 2-ton load, the highest stress that occurred is 106.08 MPa.

Another research paper by Shendge et.al. (2021) [2] on the design and FEA analysis of a double wishbone suspension system for improved handling and ride quality. The study utilized kinematic and dynamic simulations to determine the suspension's response to various road conditions. Results demonstrated that the double wishbone configuration on front ensures better control of wheel alignment angles, minimizes body roll, and enhances cornering stability.

Zhang et al. (2019) conducted a comparative study on various RANS and DES turbulence models applied to a full-scale sedan, revealing significant discrepancies in aerodynamic predictions, particularly in drag and wake flow structure. Their work highlighted the **limitations of RANS models in capturing complex separated flows** and stressed the **increasing reliability of DES models** despite their higher computational cost, especially in early vehicle aerodynamic design stages.

Sarkar et al. (2019) presented a comprehensive review of CFD-based aerodynamic studies focused on drag reduction in passenger and commercial vehicles. The review highlights the pivotal role of aerodynamic optimization in improving fuel efficiency, top speed, and vehicle stability. A consistent theme among the surveyed studies was the effectiveness of computational fluid dynamics (CFD) in the early design phase, using tools like ANSYS and SolidWorks to assess drag coefficient and wake flow structures. These findings support the use of virtual wind tunnel simulations for optimizing body shapes and frontal areas, particularly in low-speed applications such as urban electric vehicles. The importance of minimizing parasitic drag—form drag and skin friction—was also emphasized, aligning closely with the objectives of the present study on a 6-seater electric vehicle prototype.

3. Vehicle Design and modelling

3.1 Chassis

The first step to design designed a light weight ladder frame chassis for electric vehicle. The main objective is to provide a rigid structure to all the components during any collision. The specifications for 6-seater electric vehicle chassis are-

- Side bar of the chassis is made from Rectangular hollow shafts with 50 mm x 25 mm (thickness 2 mm) and 25 mm x 25 mm (thickness 1.5 mm).

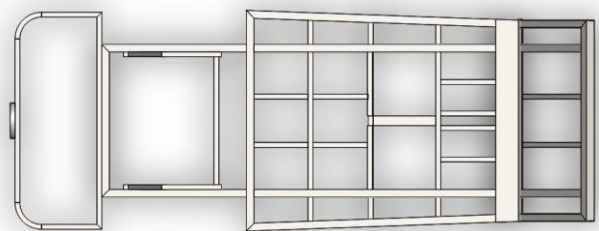

Fig -1: Top view of ladder frame chassis



Fig-2 Side view of ladder frame chassis

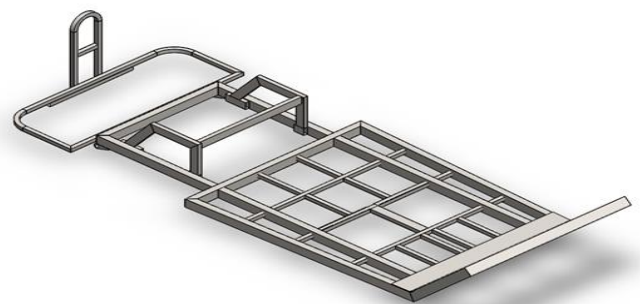

Fig -3 Isometric view of ladder frame chassis

Following considerations were taken into account while designing the chassis-

- **Wheelbase of the vehicle:** The wheelbase was selected based on the availability of differentials in the market, while also ensuring

sufficient space for two occupants. Additionally, it was designed to minimize the risk of vehicle rollover by maintaining an optimal length-to-height ratio.

- **Track width of the vehicle:** The track width was determined to provide comfortable seating for both the driver and the passenger, taking into account ergonomic seating posture and adequate legroom. It also ensured proper space allocation for the steering system, dashboard, and pedal assembly.
- **Chassis material (S275):** S275 structural steel was chosen due to its favourable balance of high strength and low cost, making it suitable for a lightweight yet robust chassis design.

3.2 Structural Analysis of the Tubular Chassis:

Shaikh [1] designed a six-seater electric golf cart with an emphasis on tubular chassis structure, solar integration, and lightweight materials, which aligns with our design goals for institutional settings.

As, mass of the vehicle and 6 passengers (excluding components which are under chassis) is 816 kg approx.

- Total load acting on chassis = $9.8 \times (816) = 8000$ N

Taking FOS as 1.6, so finally, total weight static load on chassis

$$= 8000N \times 1.5 = 12000 \text{ N}$$

We have taken uniform load to simplify calculation.

Following static structural analysis are analysed for load bearing and impact force on ladder frame chassis.

- Deformation
- Stress
- Impact analysis

Load bearing analysis of ladder frame chassis with 12000 N downward force.

Finally Following different view of the complete chassis including the ladder frame and other structure.

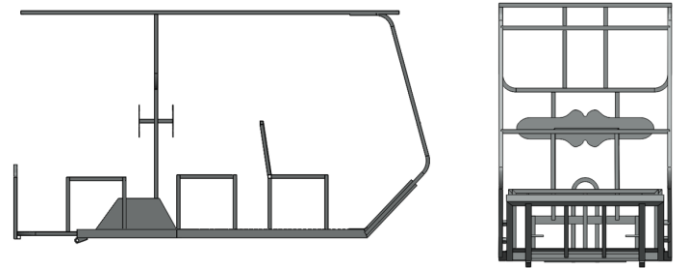

Fig- 4 From left to right: side view and front view

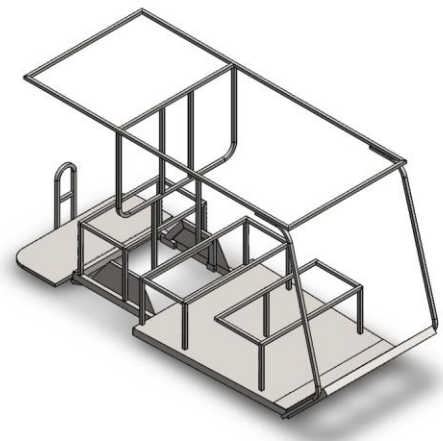

Fig- 5 Iso-metric view of complete vehicle chassis

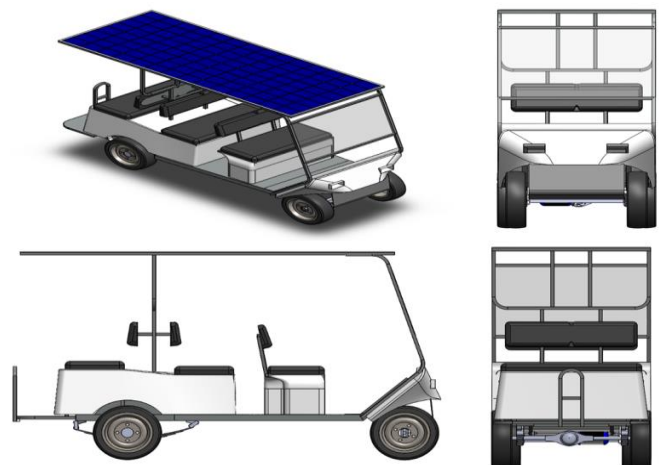

Fig- 6 Complete view of final rendered model

3.3 Load bearing Analysis

The ladder frame chassis mentioned earlier was acted upon with a load of 1560 N in the downward direction.

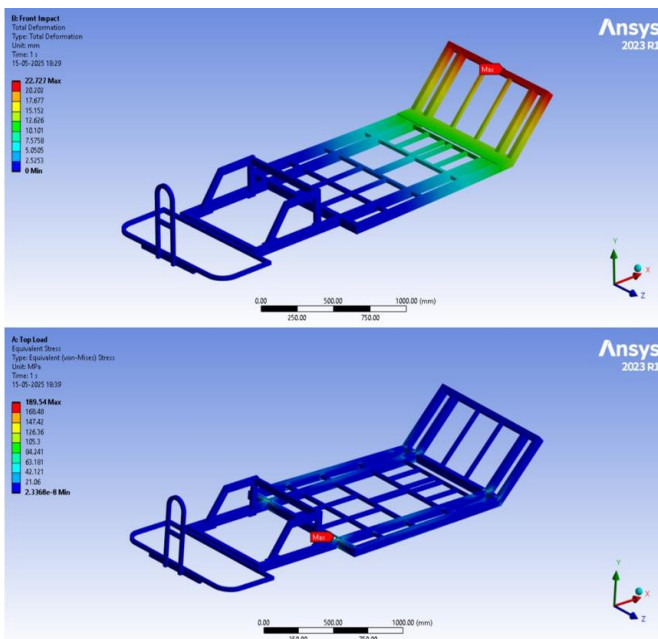

Fig- 7 From top to bottom a) Total deformation b) Equivalent stress distribution

Front impact analysis of ladder frame chassis with 10000 N force acting from front frame with rear part of the frame as fixed support.

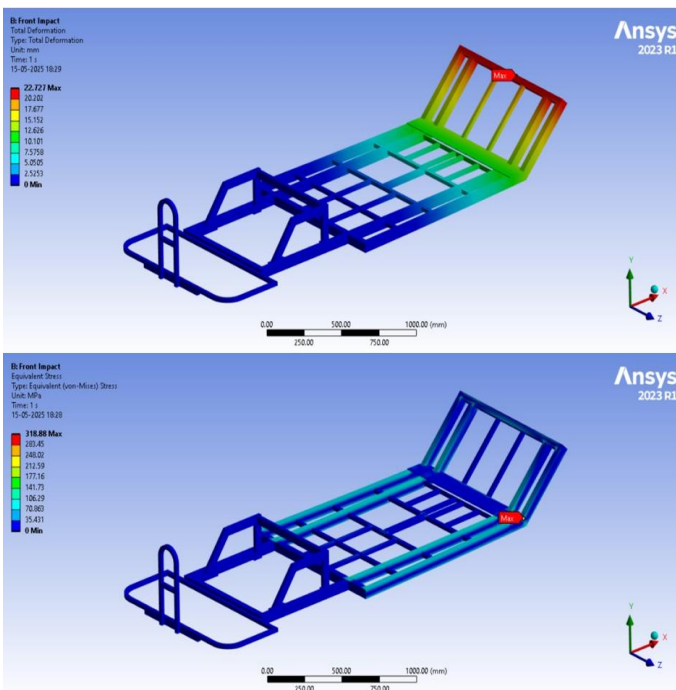

Figure- 8 Top to Bottom a) Total deformation b) Equivalent stress

Side impact analysis of ladder frame chassis with 10000 N force acting from one side of the frame with other side of the frame as fixed support.

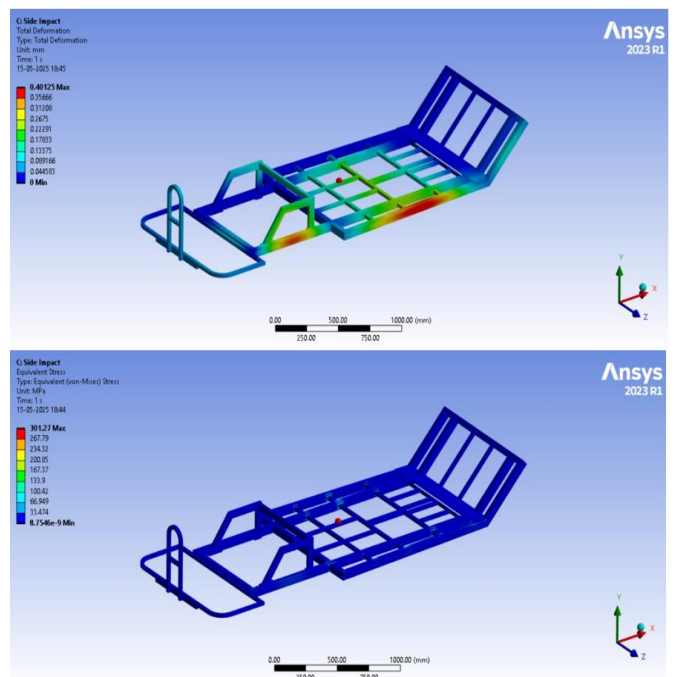

Figure- 9 Top to bottom a) Total deformation b) Equivalent stress

4. Flow analysis

4.1 Basic equation of CFD

The equations used in Computation fluid dynamics otherwise known as CFD are momentum, continuity and mass conversation also known as Navier Stokes Equation. Solving this equation would help visualize the air flow along the exterior of vehicle. Further it would help determining the high-pressure zones and the low-pressure zone. The Navier stokes equation is only applicable on incompressible fluids.

$$\frac{D\rho}{Dt} + \nabla \cdot (\rho \vec{u}) = 0$$

Where ρ is the density of the flow medium, unit is kg/m^3 , \vec{u} denotes the velocity vector and ∇

Denotes the del operator.

Momentum Equation:

$$\rho \frac{D\vec{u}}{Dt} = \nabla \cdot \vec{\sigma} + \rho \vec{g}$$

Where $\vec{\sigma} = \mu (\nabla \vec{u} + (\nabla \vec{u})^T) - (\rho + \frac{2}{3} \mu \nabla \cdot \vec{u}) I$, combined with P as the mechanical pressure in N/m^2

and μ is the coefficient of viscosity in this case.

$$\frac{D}{Dt} \left(\rho e + \frac{1}{2} \rho \vec{u} \cdot \vec{u} \right) = -\nabla \cdot \vec{q} + \nabla(\vec{\sigma} \cdot \vec{u}) + \rho \vec{g} \cdot \vec{u}$$

Where,

e = intrinsic energy per unit mass (J/kg) and

\vec{q} = Heat flux vector

4.2.1 Objective of Flow analysis

The primary objective of this flow analysis is to evaluate the aerodynamic performance of the preliminary 6-seater electric vehicle design. Since electric vehicles heavily rely on aerodynamic efficiency to maximize range. Zhang et al. [2] compared various RANS and DES turbulence models and found significant performance differences in flow separation predictions, which influenced our choice of CFD model and A comprehensive review by Sarkar et al. [4] emphasized the importance of minimizing parasitic drag in early EV designs, reinforcing the motivation behind our external flow study.

4.2.2 Software and Tools used

The aerodynamic analysis for the 6-seater electric vehicle was conducted using **SolidWorks Flow Simulation**, it comes with an integrated flow visualization system. This software allows engineers to simulate fluid flow, heat transfer, and aerodynamic forces directly on 3D CAD models without the need for external meshing or preprocessing tools. Azmi et al. [3] demonstrated the use of realizable k- ϵ turbulence modeling for MPV designs, recording drag coefficients that informed our simulation benchmarks

It uses the Finite volume method (FVM) to solve the governing Navier-stokes equation. The domain is separated into small cells and the equations are applied to individual cells.

The flow is assumed to

1. Steady-State
2. Incompressible
3. Turbulent

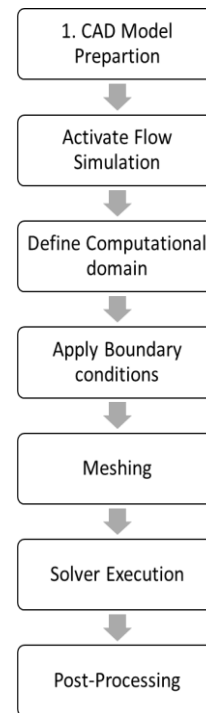

Flow Chart for CFD methodology

4.2.3 Results and discussion

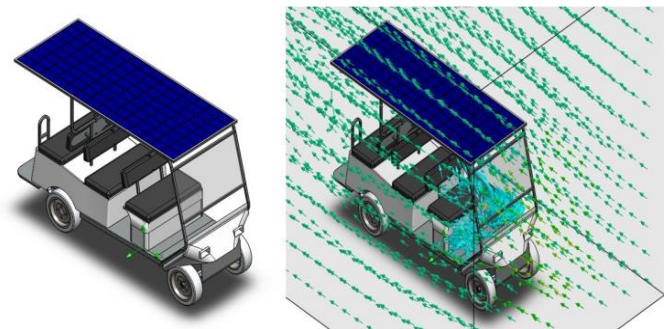

Fig- 10 Left to Right: a) CAD model of a 6-seater EV b) Isometric view for flow visualization

Left: SolidWorks CAD model of the 6-seater electric vehicle, featuring a solar panel-integrated roof. The design includes three rows of seating, a simplified chassis, and a streamlined frontal section to reduce aerodynamic drag.

Right: Visualization of external airflow using SolidWorks Flow Simulation. Velocity vectors illustrate the airflow behavior around the vehicle. Flow separation is noticeable at the windshield and rear region, while the flat roof and sharp edges contribute to wake formation. The simulation confirms the necessity for aerodynamic refinements to reduce drag and improve energy efficiency.

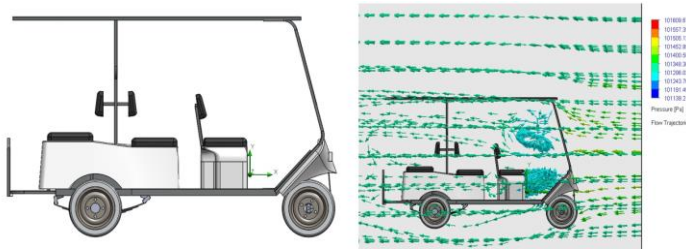

Fig- 11 Left to Right: a) Side view of a 6-seater EV b) Side view for flow visualization

Left: Side elevation of the 6-seater electric vehicle designed in SolidWorks, showing the simplified body profile, driver and passenger seating arrangement, and

solar panel-integrated roof structure. The linear chassis layout is optimized for structural simplicity and ease of packaging components.

Right: Pressure contour and flow trajectory visualization from SolidWorks Flow Simulation. The color scale represents the static pressure distribution in pascals(Pa), highlighting high-pressure accumulation at the front surface and sharp pressure drop in the wake region behind the vehicle.

Table showing values of different parameters at speed 8.33 m/sec (30 km/hr)

Parameter	Unit	Value
Maximum Total Pressure	Pa	101455
Maximum Dynamic Pressure	Pa	82.13
Average Velocity	m/s	7.596
Maximum Velocity	m/s	11.679
Average Velocity (X)	m/s	-7.540
Maximum Velocity (X)	m/s	3.227
Aerodynamic Force (Drag)	N	81.882

Table showing values of different parameters at speed 11.11 m/sec (40 km/hr)

Parameter	Unit	Value
Maximum Total Pressure	Pa	101533.8
Maximum Dynamic Pressure	Pa	135.73
Average Velocity	m/s	10.890
Maximum Velocity	m/s	15.012
Average Velocity (X)	m/s	-10.866
Maximum Velocity (X)	m/s	4.258
Aerodynamic Force (Drag)	N	134.971

CONCLUSION

The preliminary study presented here explored design and simulation for a 6-seater electric vehicle, tailored for short distance application such as inter-campus commute and usage inside a residential complex. The ladder type chassis was structured and analysed under various loads and impact conditions using ANSYS. These tests were performed to confirm its ability to withstand operational loads. The external flow analysis performed inside SOLIDWORKS flow simulation tab was also use-full in revealing pressure, temperature and drag force along the surface of the vehicle body. The tests reveal a drag force of 81.88N and 134.97N at 30km/hr and 40km/hr respectively.

The study confirms the utility of simulation based approach in early phases of design where budget and resource constraints are very prominent.

Future Scope

Future studies can be focused on reducing drag, enhancing thermal management system and usage of suspension system to increase ride comfort of the vehicle for more practical usage along with integrating advanced electronics system such as regenerative braking. The foundational work has been set for further prototyping and real-world application

REFERENCES

- 1. Design of an Electric Golf Cart with Batteries & Solar Panel for 6 Seat Capacity**
M. A. Shaikh, "Design of an Electric Golf Cart with Batteries & Solar Panel for 6 Seat Capacity," *International Research Journal of Engineering and Technology (IRJET)*, vol. 6, no. 2, pp. 2103–2110, Feb. 2019.
- 2. Turbulence Modeling Effects on the CFD Predictions of Flow over a Detailed Full-Scale Sedan Vehicle**
C. Zhang, C. P. Bounds, L. Foster, and M. Uddin, "Turbulence modeling effects on the CFD predictions of flow over a detailed full-scale sedan vehicle," *Fluids*, vol. 4, no. 3, p. 148, Aug. 2019, doi: [10.3390/fluids4030148](https://doi.org/10.3390/fluids4030148).
- 3. Vehicle Aerodynamics Analysis of a Multi-Purpose Vehicle Using CFD**
M. F. M. Azmi, M. A. B. Marzuki, and M. A. A. Bakar, "Vehicle aerodynamics analysis of a multi-purpose vehicle using CFD," *ARPN Journal of Engineering and Applied Sciences*, vol. 12, no. 7, pp. 2345–2346, Apr. 2017.
- 4. A Review Paper on Aerodynamic Drag Reduction and CFD Analysis of Vehicles**
S. Sarkar, K. Thummar, N. Shah, and V. Vagrecha, "A review

paper on aerodynamic drag reduction and CFD analysis of vehicles," *International Research Journal of Engineering and Technology (IRJET)*, vol. 6, no. 1, pp. 231–233, Jan. 2019.