

# Solar-powered Charging Station Vending Machine

Alberto Delaña<sup>1</sup>, Cloue Deriada<sup>2</sup>, Leslie Esparar<sup>3</sup>

<sup>1</sup> Assistant Professor, Department of Electrical Engineering, CPSU, Kabankalan City, Philippines

<sup>2</sup> Instructor, Department of Electrical Engineering, CPSU, Kabankalan City, Philippines

<sup>3</sup> Science & Research Specialist, Department of Science and Technology, Philippines

\*\*\*

**Abstract** - The Solar-Powered Charging Station Vending Machine is a standalone device designed to provide reliable mobile phone charging services in areas with limited or no access to electricity. Developed to address the growing dependence on mobile phones for communication, online learning, and business—especially in remote communities and during power outages—the system harnesses renewable solar energy, thereby reducing carbon footprint and promoting environmental sustainability. The design process involved determining load requirements, sizing solar panels, charge controllers, batteries, conductors, and over-current protection devices. The final prototype featured two USB charging ports and an LED light, powered by a 100 W solar panel, 10 A charge controller, and 80 Ah sealed lead-acid battery, with vending capability based on coin operation. Reliability testing was conducted over 20 days at a public transport terminal, serving 35 smartphones and 40 basic phones. Results showed the vending mechanism performed precisely according to coin-set charging times, with smartphones achieving an average 57% increase in battery capacity and basic phones achieving a 248% increase in charge bars. The study concludes that the machine is highly reliable for both charging and vending operations. Recommendations include increasing the number of charging ports, adding laptop-compatible outlets, and improving portability. This project demonstrates a practical, eco-friendly, and income-generating solution for energy access in underserved areas, contributing to both technological innovation and sustainable development goals.

**Key Words:** Solar energy, charging station, vending machine, renewable energy, mobile phone charging, off-grid system, sustainable technology

## 1. INTRODUCTION

Solar energy is a major renewable energy source that is both eco-friendly and capable of addressing many of the world's pressing challenges. With technological advancements, various devices have been developed to harness solar power, such as the Solar Home System (SHS) and Battery Charging Station (BCS). Alongside these developments, mobile phones have become an essential part of daily life for people worldwide. Their role in maintaining communication with family, managing business affairs, connecting with associates, and providing instant access to social media underscores their growing importance. However, frequent usage leads to high battery consumption, resulting in faster

battery depletion. This becomes a significant concern for commuters without power banks, as well as for communities in remote areas and during power outages, where access to charging facilities is limited.

## Background of the study

The COVID-19 pandemic has made cellphones, particularly smartphones, an essential tool in the academe, as academic institutions shifted from traditional face-to-face classes to online learning. However, not all communities have access to electricity, and those beyond the reach of electric utilities struggle to charge their devices—now vital for education and communication. Frequent brownouts caused by system failures, environmental factors, and human error further compound the problem. To address these challenges, the researchers developed a stand-alone, solar-powered charging station for mobile phones, independent of the electrical grid. Designed as a vending machine, the system also offers an income-generating opportunity for individuals who adopt the technology. This project is especially beneficial to people in remote areas, commuters, and small entrepreneurs seeking passive income during the pandemic. By using a renewable energy source, it produces zero carbon emissions, contributing to climate change mitigation. The study aims to design and test the reliability of the charging station's vending and charging capabilities, while providing a sustainable power source for underserved areas.

## 2. Methodology

This study employed an applied research approach, focusing on the design, fabrication, and performance evaluation of a solar-powered charging station vending machine. The methodology was structured to ensure the device's technical reliability, operational efficiency, and suitability for deployment in off-grid and public areas. The process began with determining the total daily load requirements of the charging station, which served as the basis for the sizing of major system components, including the solar panel, charge controller, battery storage, conductors, and over-current protection devices. Standard engineering calculations and relevant provisions of the Philippine Electrical Code were applied to ensure safety, efficiency, and compliance with industry standards. Once the design parameters were established, the prototype was fabricated using readily available materials and components in the local market. The assembled unit was then subjected to a 20-day field testing

period at a public transport terminal to evaluate both its charging performance and vending functionality under real-world conditions. Data gathered from the tests were analyzed to determine the system’s charging efficiency, reliability, and potential scalability for commercial and community applications.

**2. 1. Steps in designing solar-powered charging station vending machine**

- Step 1. Determine your power/load consumption (Wh per day);
- Step 2. Sizing of solar panel (Wp);
- Step 3. Sizing the DC charge controller (A);
- Step 4. Sizing the batteries (Ah).;
- Step 5. Sizing of conductors (mm2);
- Step 6. Sizing of over-current protection (A).

**2. 2. Design Analysis with load consideration**

2-USB port, 10 watts each for charging mobile phones in 10 hours (8am-6pm) every day.

1-5V DC LED bulb, 5 watts for 1hr (5pm-6pm) every day.

Five (5) hours as the average daily solar exposure (Sun-Hour) in a day.

**Table -1:** Schedule of loads

Load description	Power rating	Operating hours	Watt-hour rating
USB port	10 watts	10 watts	100 Wh
USB port	10 watts	10 watts	100 Wh
LED bulb	5 watts	1 hr	5 Wh
Total			205 Wh

*Determination of power consumption in Watt-hour/day*

Power consumption in watt-hour/day, taking the overall efficiency of the system to be seventy percent. Power consumption = [(10W x 10hours) + (10W x 10hours) + (5W x 1hour)]/0.7 = 292.85 watt- hour/day

*Sizing of solar panel (Wp)*

$I_{pv} = [\text{Power Consumption}] / [\text{system voltage} \times \text{sun-hours in a day}]$  Where:  $I_{pv}$  = photovoltaic total current required to charge the battery from the solar panel (Amperes) System voltage = dc voltage used in the system (12v dc system) Sun-hours in a day = the average number of hours the solar energy can be captured within a day (sun-

hours).  $I_{pv} = [\text{Power Consumption}] / [\text{system voltage} \times \text{sun-hours in a day}] = [292.85 \text{ watt-hour/day}] / [12 \text{ Volts} \times 5 \text{ sun-hours}] = 4.88 \text{ Amperes}$

Therefore, based on solar panel wattage rating for 2Watts to 300Watts, the approximate solar panel wattage would be 90 watts but due to availability constraints in the market of that size the researchers used 100 watts solar panel instead.

*Sizing the charge controller*

The charge controller is rated in Amperes. Its rating depends on the amount of photovoltaic current,  $I_{pv}$ . To ensure that it is not overloaded, 20% of  $I_{pv}$  is usually added as an allowance. Charge controller size

=  $I_{pv} + (20\% \text{ of } I_{pv}) = 4.88 + (4.88 \times 0.2) = 5.86 \text{ Amperes}$ . Therefore, the size of the solar charge controller to be used must be 5.86A or higher in rating. Due to unavailability of that rating in the market the next higher of 10A rating was used in this project.

*Sizing the battery & battery sizing considerations*

The machine should be 12 Volts dc system. Battery should be used only at fifty percent deep of discharge (50% DOD) Days of autonomy should be 2 days or 48 hours. Battery size = [Total load in watt- hour] / [battery deep of discharge x system voltage] = [205 watt-hour/day] / [0.5 x 12V] = 34.17 Ampere- hour required battery size for two days autonomy:

Required battery size= [battery size in Ampere-hour] x [number of days of autonomy] = [34.17 Ampere-hour] x [2 days] = 68.34 Ampere-hours. Therefore, the battery to be used must be equal to 68.34 Ampere-hours or higher in rating. Since the said rating is not available in the market the researcher used the next higher rating of 80 Ampere-hours. For this project, the researchers used 80 Ampere-hours sealed lead acid battery.

*Conductor size calculation*

$$A = \frac{(2D \times I_{pv})}{(\sigma \times \Delta v)}$$

Where: A : cross-sectional area of the cable; D: maximum length of the cable : 4m  $I_{pv}$ : current from the solar panel : 4.88A;  $\sigma$ : conductor used for the cable (specific conductivity of copper) :  $56 \times 10^6 \text{ A/V}$ ;  $\Delta v$  : total voltage drops by the cable; : this is usually taken to be 3% of the system voltage.;  $\Delta v$  : (3% of 12V) =  $0.03 \times 12 = 0.36 \text{ V}$

$$A = \frac{(2D \times I_{pv})}{(\sigma \times \Delta v)}$$

$$A = \frac{(2)(4) \times 4.88}{(56 \times 0.36)} = 1.94 \text{ mm}^2$$

The conductor size to be used should be equal to or greater than  $1.94 \text{ mm}^2$ . Since the said conductor size is not available in the market the researchers used the next higher size of  $2.0 \text{ mm}^2$ . The researcher used  $2.0 \text{ mm}^2$  THW copper conductor.

*Solar panel to charge controller OCPD size*

$$\text{OCPD size} = \text{short circuit rating of the pv panel} \times 125\%$$

$$= 6.25\text{A} \times 1.25$$

$$= 7.81 \text{ Amperes}$$

Therefore, the OCPD size to be used must be equal to 7.81A but since the said rating is not available in the market the researchers used the next higher rating of 8 Amperes. In this project the researchers used 1-8 Amperes fuse.

*Charge controller to battery OCPD size*

In determining the fuse size needed between the charge controller and battery it simply need to match the amperage rating on the charge controller. Therefore, charge controller to battery OCPD size is equal to Charge controller size. In this project the researchers used 10 Ampere fuse.

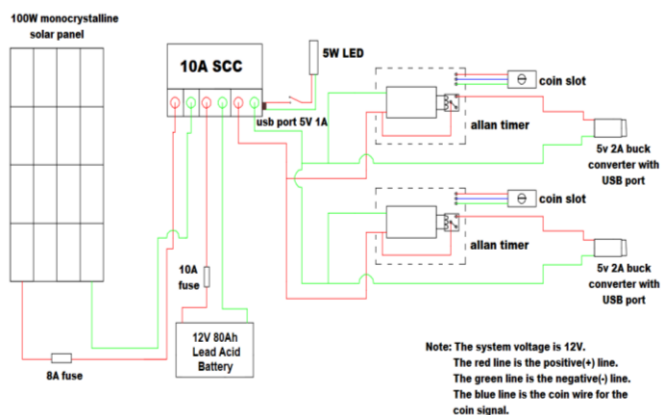

Figure 1. Circuit Diagram

**3. Results**

The solar-powered charging station vending machine was tested over a 20-day period at the Ceres Terminal, Barangay Bantayan, Kabankalan City, serving a total of 35 smartphones and 40 basic phones of various brands.

Table 2. Test results

Phone type (random brand)	Mean time	Mean time Actual	Mean Battery status		
			Before	After	% increase
Smart phones	34.57	34.57	28.74%	45.31%	57 %
Basic phones	29.25	29.25	0.87%	3.03%	248 %

Note: \*time in minutes setting based on coins inserted by clients; \*\*time done by the machine

The vending mechanism demonstrated precise performance, delivering charging durations exactly matching the time set by coin insertion. For smartphones, the device increased battery levels from an average of 28.74% to 45.31%, equivalent to a 57% gain. For basic phones, battery status rose from an average of 0.87 to 3.03 bars, representing a 248% increase. These results indicate that the system is both reliable and effective in providing timed charging services for different mobile phone types under real-world operating conditions.



Figure 2. The machine in the public transport

**3. CONCLUSIONS**

The results of the 20-day field test demonstrated that the solar-powered vending machine charging station is highly reliable. Its vending mechanism consistently delivered charging durations that matched the preset time based on the coins inserted, while effectively charging various types and brands of mobile phones. This validates the system's capability as both a sustainable energy solution and a functional income-generating device.

To further enhance the machine's functionality and market potential, the following improvements are recommended:

1. Increase the number of charging ports to allow simultaneous charging of more mobile devices.
2. Add charging ports compatible with laptop computers.
3. Upgrade the machine's construction using lightweight materials to improve portability and ease of transport.

**REFERENCES**

[1] M. Boxwell, *Solar Electricity Handbook 2017 Edition: A Simple, Practical Guide to Solar Energy—How to Design and Install Photovoltaic Solar Electric Systems*. Birmingham, U.K.: Greenstream Publishing Ltd., 2017.

[2] BatteryStuff.com, "Battery basics: A layman's guide to batteries," *We Have The Stuff*, Apr. 12, 2021. [Online]. Available:

<https://www.batterystuff.com/kb/articles/battery-articles/battery-basics.html>

[3] CCL Components, "Choosing the correct solar charge controller," Aug. 2020. [Online]. Available: <https://blog.cclcomponents.com/solar-charge-controller-choosing-the-right-one>

[4] R. Elder, "Creating new markets in the lifecycle of connected things: Starting at the end—Obsolescence planning," Feb. 11, 2019. [Online]. Available: <https://blog.equinix.com/blog/2019/02/11/creating-new-markets-in-the-lifecycle-of-connected-things/>

[5] P. I. Okwu *et al.*, "Details of photovoltaic solar system design calculations and accessories," *International Journal for Research in Applied Science in Engineering Technology (IJRASET)*, vol. 5, no. 6, pp. 1–6, 2017.

[6] *Philippine Electrical Code Part 1*. Quezon City, Philippines: Institute of Integrated Electrical Engineers of the Philippines, Inc., 2017.

[7] WindyNation, "How to properly fuse a solar PV system," Jan. 13, 2010. [Online]. Available: <http://www.windynation.com/articles/how-properly-fuse-solar-pv-system>

[8] S. Writer, "What is a list of electronic devices?," Apr. 1, 2020. [Online]. Available: <https://www.reference.com/world-view/list-electronic-devices>