

MULTILEVEL INVERTER BASED VFD FOR THREE PHASE INDUCTION MOTOR

Vishnudas C S¹, Sreehari S²

¹ Student, Electrical And Electronics Department, Adi Shankara Institute of Engineering And Technology, Kerala, India

² Assistant Professor, Electrical And Electronics Department, Adi Shankara Institute of Engineering And Technology, Kerala, India

Abstract - Numerous industrial applications requires apparatus with require higher power and also some medium voltage motor drives and utility applications need medium voltage and megawatt power levels. It is vexatious to connect only one power semiconductor switch directly for a medium voltage grid. Respectively, a multilevel power converter structure has been introduced for high power and medium voltage situation as an alternative. Multilevel Inverters usually achieve high power ratings, and also enable the use of renewable energy sources such as photovoltaic, wind, and fuel cells. Multilevel Inverter's achieves higher power by using power semiconductor switches with several dc voltage sources. MLI's perform the power conversion by synthesizing a desired staircase voltage waveform. The commutation of these power switches aggregates these multiple DC sources for achieving high voltage at the output. Also the rated voltage of the power semiconductor switches depends only on the rating of the dc voltage sources to which they are connected. In this paper a survey on various multilevel inverter topologies is studied along with its various modulation techniques. Simulation is carried out using MATLAB / SIMULINK. The simulation is carried out for NPCMLI with ILBC for an unmodulated system, driving a motor drive as load. The results show that the DC Link unbalance in NPCMLI can be avoided using ILBC and required motor speed can be maintained for an unmodulated system.

Key Words: MLI, NPC Inverter, ILBC...

1. Introduction

Power inverters are basically circuits that convert DC signals to AC signals. First things first so the question come, why we require inverters in first place? That's simple because AC signal travels easily and is more useful in our daily appliances. And now the question comes why multilevel inverters are required? and the answer to that is even simpler i.e., it is much easier to use multilevel inverters in preference to using multiple power lines. Another million dollar question is what's the difference

between conventional inverters and a multilevel inverter? And the answer to this is as follows:

1. MLI's helps to provide higher power levels.
2. Multiple switches are used to operate MLI's instead of one.
3. MLI's can convert environmental friendly energies like Wind, solar etc to AC.

2. Working of a multilevel inverter, Types And Applications

Switching frequency is the key feature of inverter. Fast switching of DC signal bequeathing multiple levels is obligatory to convert DC signals to AC signals which pirouette into a staircase wave that is nearest to typical sine wave. There are substantially three types of multilevel inverters:

Cascaded H-Bridges - The circuit consists mainly of diodes and switches and usually uses Separate DC sources (SDCs). Haphazardly, due to vogueish progressions, H-Bridge Cascaded inverters with single DC source can also be formed. H-Bridge Cascaded multilevel inverters can invert up to three voltage levels. The distinctive positions of switches determine distinctive voltage levels.

Diode Clamped - DCMLI's uses capacitors and diodes for inversion. Conversion of DC voltage into capacitor voltage is the main desideratum of DCMLI's. To avoid over charging of capacitors proper precautionary measures should be taken.

Flying Capacitor - As the capacitors need to be pre charged this method is relatively a complicated way of inversion. Contrariness is that clamping is done through capacitors instead of diodes in FCMLI's. FCMLI's are also known as imbricated cell multilevel inverter.

Owing to the usefulness of MLI's bounteous research are still underway regarding MLI's. Numerous topologies have been conferred to make most out of these basic MLI topologies. The output waveform can be either a sine wave or can be a modified sine wave.

Two methods or modes for converting DC voltage to AC voltage are :

_ Convert DC signals to Higher-Power DC signals and then convert it to required AC.

_ Convert DC signals to AC signals at the lower level and then using line frequency we get the requisite output voltage.

The potential applications of Multilevel Inverters are generally in industrial applications. Multilevel inverters are indubitable in the areas where we need higher power levels. Some areas of usage include power conditioning, active filters, industrial motor drives etc.,

3. Relevance of the Area And Objective

In recent years, MLI's has achieved some significant advantages over traditional two-level converters, especially in case of high power and high voltage applications, in addition to MLI's first-rate output voltage quality. MLI's are also capable of reducing voltage stress across switching devices. Lower dv/dt is achieved as the output voltages have multiple levels, which greatly assuage EMI problems as a result of high frequency switching. In general, as there are many voltage levels, MLI's have the less harmonic contents and better power quality. A major concern for MLI is the increase in converter complexity and number of switching devices. By this research on speed control of NPC MLI it will be possible to improve Staircase waveform quality and also can reduce the Total Harmonic Distortion (THD) in case of a variable frequency drive (VFD).

Also the DC link unbalancing of NPC MLI is effectively rectified using Interleaved Buck Converters (ILBC).

The objectives includes

1. To improve the output waveform of the MLI and thereby reduces its respective harmonic content and hence the size of the filter used the level of EMI generated by the switching operation of the inverter.
2. Eliminate the DC link unbalancing in NPC inverter using ILBC.

1.1 Neutral point clamped MLI

The use of voltage clamping diodes is vital in NPCMLI topology. A common DC bus is divided by an even number, which depend on the number of voltage levels in the inverter. Also bulk capacitors are implanted in series with a neutral point in the middle of the line. The reason for the inverter to have clamping diodes connected in series is so that all diodes can be of the same voltage rating and be able to block the right number of voltage levels. Using diodes and limiting the power devices voltage stress is the main concept of this inverter. V_{dc} is the voltage over each capacitor and each switch. As the numbers of voltage levels are increased the quality of the output voltage is more appropriate and the voltage waveform becomes closer to sinusoidal waveform.

Advantages of NPCMLI includes

1. Harmonic content will be very low enough to obviate the need for filters when the number of levels is high.
2. Efficiency is high as all devices are being switched at the fundamental frequency.

Figure .1 shows the Neutral point clamped multilevel inverter.

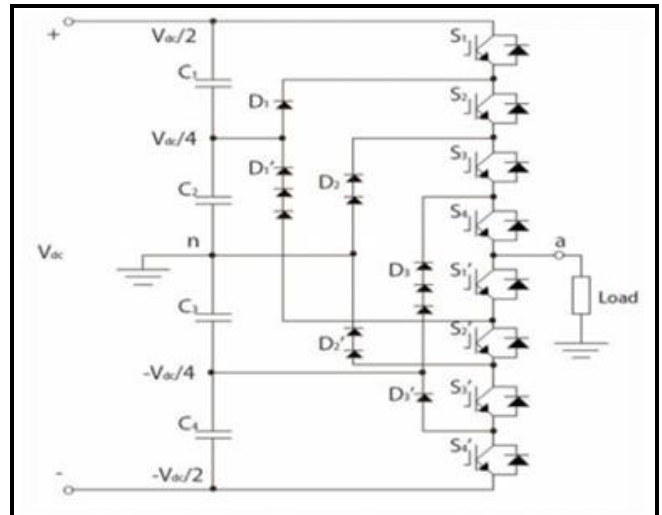

Fig 1: NPC inverter general structure

1.2 Interleaved buck converter

The basic function of buck converters is converting DC voltage to step down DC voltage. Interleaving adds additional aids such as reduced ripple currents in input and output circuits. The output current is split into two paths, this realize higher efficiency by substantially downing losses. Interleaved techniques found application in very early days. The interleaved technique finds application in high power as the voltage and current stress can easily clear of the range that one power device can tiller. Parallel and/or series connection of multiple power devices could be a better solution to this issue. The concerns that still prevail are voltage and current sharing. Paralleling converters is a quick fix which could be more benign like harmonic cancellation, better efficiency and thermal performance, and high power density than paralleling power devices.

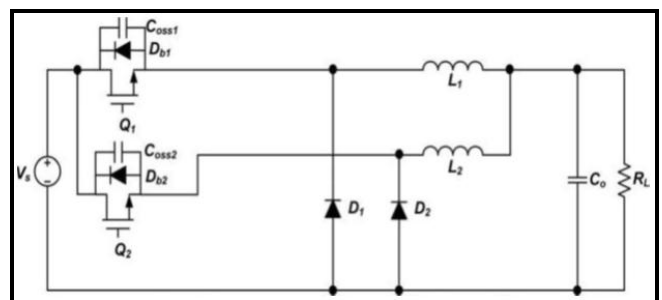

Fig 2: ILBC general structure

An ILBC usually integrates more than two conventional topologies, and in the same power condition, the current in the element of an ILBC is half of that of the conventional topology. To reduce the switching losses of the high-frequency switching, single buck converter can use either zero-voltage switching (ZVS) and/or zero-current switching (ZCS). Due to simple structure and low control complexity an interleaved buck converter (ILBC) has received a lot of attention, in applications where high output current with low ripple and step-down conversion ratio are required.

However, in the conventional ILBC shown in Figure 2. high rated voltage devices aloft the input voltage should be used since all the semiconductor devices endure from the input voltage. Characteristics such as high cost, high on resistance, high forward voltage drop, severe reverse recovery are generally destitute in case of high-voltage-rated devices. High cost and poor efficiency arise when operated under hard switching condition. The converter act on higher switching frequencies for higher power density and better dynamics but increase the switching losses cognated with turn-on, turn-off, and reverse recovery. An extremely short duty cycle is experienced in the case of high-input and low output voltage applications. In short, before turn-on or after turn-off, when the operating duty is below 50, the voltage stress across all active switches is halved to that of the input voltage.

2 Simulation Results

The Simulink model of an uncompensated Neutral Point Clamped Inverter driving a motor load (IM) with ILBC is as shown in figure 2.1. The model consists of NPC Inverter with ILBC (for an unbalanced system), which balances the DC link voltage of NPC Inverter. It provides constant voltage across the capacitors and which in turn provides for the efficient charging and discharging of the capacitor.

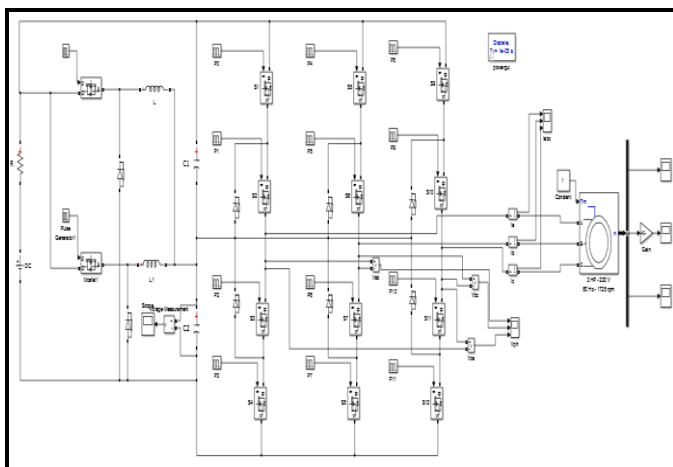

Fig -1: Matlab/Simulink model of NPC inverter with ILBC (uncompensated system)

2.3 Voltage waveform of NPC inverter with ILBC system

Figure 2 shows the phase voltages of the NPC inverter with ILBC model.

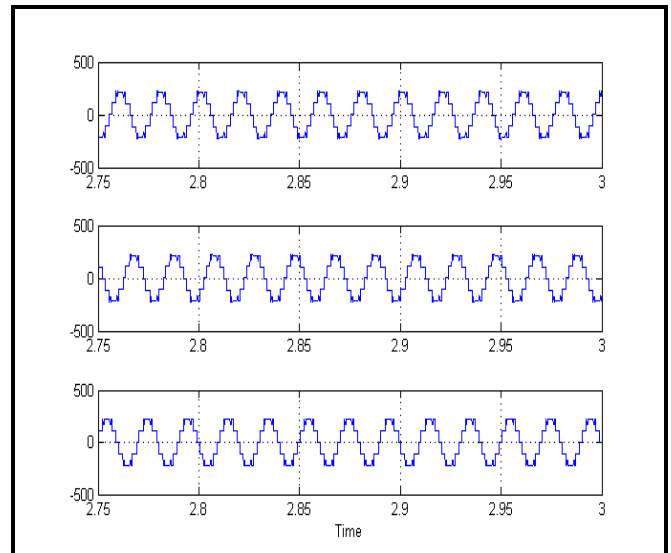

Fig -2: Voltage waveform of NPC inverter with ILBC (uncompensated system)

2.3 Speed of motor of NPC inverter with ILBC system

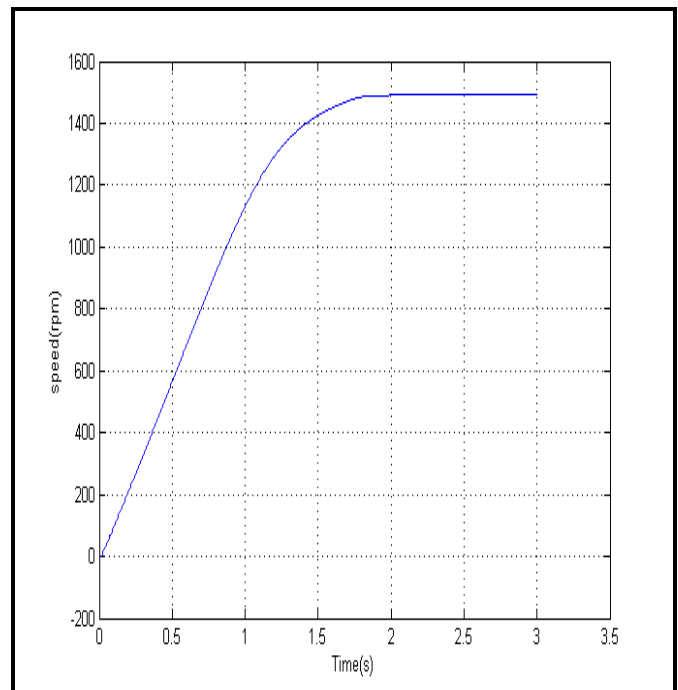

Fig 3: Motor speed of NPC inverter with ILBC (uncompensated system)

2.3 Speed of motor of NPC inverter with ILBC system

Figure 4 shows the DC link Capacitor voltage. Here by the use of ILBC for DC link capacitor balancing, we get the desired waveforms and desired speed. The capacitor voltage is maintained to a constant value by ILBC.

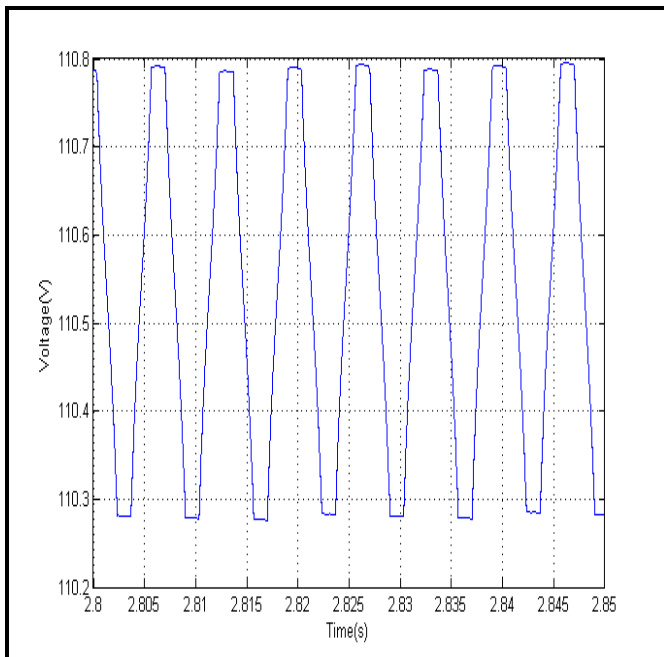

Fig 3: DC Link Capacitor voltage of NPC inverter with ILBC (uncompensated system)

3. CONCLUSIONS

Even though an early patent for the multilevel inverter can be traced back to 1975, however the commercial products that utilize this superior circuit topology were not available until mid 1990s. Today more commercial products are based on the MLI structure, and more worldwide research and development of MLI related technologies is occurring.

In this report, the survey on various MLI topologies and control schemes has been presented. Introduction of ILBC for DC Link unbalancing were also discussed. An insight in different control techniques and its benefits, classification of existing and new methods were studied with their advantage and disadvantages. A study on the NPCMLI for an unmodulated system has been carried out by MATLAB SIMULATION runs confirming that the DC link unbalancing can be effectively overcome by using ILBC across the capacitor in the DC Link. The simulation of the proposed system has been done for unmodulated system by taking motor drives as the application area is described in this project. Effectiveness of the model in speed control of motor drives over a wide range of operating conditions

can be carried out introducing control schemes. The future work on the thesis includes the speed control of motor drive using SVM control scheme using DTC/FOC algorithm.

ACKNOWLEDGEMENT

This is not mandatory. I would like to express my sincere gratitude to our institution, Adi Shankara Institute Of Engineering and Technology, Kalady. I also thank our honorable Principal Dr. N. Hariharan for providing us with all the facilities for making my project a success.

I am grateful to the Head of the Department Prof. Krishnakumari.T for her constant encouragement and support.

I would like to extend my gratitude to my guide Mr. Sreehari S, Assistant Professor of EEE department for his inspiring assistance, support and timely advice and for her enterprising attitude that made my project successful.

Also I would like to thank our PGPP Divakara Menon Sir of the department for giving us innovative suggestions and assisting us in times of needs. This acknowledgement will stand incomplete if my parents, friends and classmates are not thanked whose constant encouragement and timely criticism helped us to a great extent. They were instrumental in keeping my spirit high and their association with me will be always remembered.

REFERENCES

- [1] J. P. F. Rodriguez, J.; Lai, \Multilevel inverters: Survey of topologies, controls, and applications," Transactions on Industry Applications., vol. 49;no.4., Aug.2002;pp.724-738.
- [2] F. Lai, J.S.; Peng, \Multilevel converters-a new breed of power converters," IEEE Trans. Ind. Applicat., vol. 32;pp.509-517, May/June 1996.
- [3] I. H. Nabae, A.; Takahashi, \A new neutral-point clamped pwm inverter," IEEE Trans. Ind. Applicat., vol. IA-17;pp.518-523, Sept/Oct.1981.
- [4] F. H. T. Tolbert, L.M; Peng, \Multilevel converters for large electric drives," IEEE Trans. Ind. Applicat., vol. 35;pp. 36-44, Jan./Feb. 1999.
- [5] K. Damodharan, P.; Vasudevan, \Indirect back-emf zero crossing detection for sensorless bldc motor operation." In Proceedings of the International Conference on Power Electronics and Drives Systems (PEDS 2005), Kuala Lumpur, Malaysia, 28.
- [6] R. Patel, H.S.; Hoft, \Generalized harmonic elimination and voltage control in thyristor converters: Part i harmonic elimination," IEEE

Transactions on Industry Applications, vol. 9; pp.310-317, Sept./Oct. 1974.

- [7] T. Sinha, G.; Lipo, \A new modulation strategy for improved dc bus utilization in hard and soft switched multilevel inverters," IECON, 1997.a. Juan Manuel Carrasco; and et, \Power electronics systems for the integration of renewable energy sources: a survey," IEEE Trans. on Industrial Electronics, vol. 53; no.4, August 2006.
- [8] R. R. C. P. K. G. K. Sivakumar, A. Das, \A ν ve level inverter scheme for a four pole induction motor drive by feeding the identical voltage profile windings from both sides," IEEE Trans. on Industrial Electronics(accepted for publication.
- [9] A. d. C. P. K. K.Sivakumar, Rijil Ramchand, \Two different schemes for three-level voltage space vector generation for induction motor drives with reduced dc-link voltage," EPE(European power electronics journal),(accepted for publication and scheduled on march 2010.
- [10] L. . A. M. . W. S. Sejjal, L. ; Lopes, \Neutral-point voltage balancing of three-level ev traction inverter using modified carrier-based svm and thd comparison with a two-level inverter," Transportation Electrification Conference and Expo (ITEC), 2013.
- [11] F. . S. L. Yang Jiao ; Lee, \Space vector modulation for three-level npc converter with neutral point voltage balance and switching loss reduction," Power Electronics, IEEE Transactions, vol. 29, 2014.
- [12] I. . A. S. . A. I. . M. D. Mazuela, M. ; Baraia, \Comprehensive analysis of voltage balancing techniques for 5l-npc converters," Power Electronics and Applications (EPE), 2013 15th European Conference, 2013.
- [13] J. . P. E. Betanzos, J.D. ; Rodriguez, \Space vector pulse width modulation for three-level npc-vsi," Latin America Transactions, IEEE (Revista IEEE America Latina), vol. 11, 2013.

BIOGRAPHIES



Vishnudas C S was born on 27th February 1991. He received her Bachelor Of Technology Degree In Electrical And Electronics from Toc H Institute Of Science And Technology, Arakkunnam under Cusat University in 2013. He is currently pursuing Master Of Technology In Power Electronics And Power System at Adi Shankara Institute Of Engineering And Technology Kalady, Ernakulam. His current research interests include Speed control of VFD using Multilevel Inverters.



Sreehari.S was born in Kerala, India. He received his Bachelor of Technology Degree in Electrical and Electronics engineering in 2010 from Calicut University of Engineering and Technology. Masters of Technology Degree from Amrita School of Engineering, Coimbatore in 2013.He is currently work as a Assistant Professor in Adi Shankara Institute of Engineering and Technology ,Cochin. His current research interests include Power Electronics and Power System.