

“ DESIGN OF FINITE ELEMENT MODEL FOR THE EFFECT OF HEAT INPUT & SPEED ON RESIDUAL STRESS DURING WELDINGS ”

Kiran D Gaidhani¹, Prof V L Kadlag²

¹ Research scholar Mechanical engineering department SVIT COE Chincholi. SVIT COE CHINCHOLI-422101, Maharashtra (INDIA).

² Professor and head of Mechanical workshop department SVIT COE Chincholi. SVIT COE CHINCHOLI-42210, Maharashtra (INDIA).

ABSTRACT — This report is a presentation of ANSYS FE models for the thermal and mechanical welding simulation. To develop suitable welding models, we must consider the process parameter (welding speed, Heat flux, Gap and Temperature), the geometrical constraints, the material nonlinearities and all physical phenomena involved in welding. Therefore it is a great challenge to consider all factors at the same time, so generally the models include some approximations: in the works ,we can find some attempts to reduce modelling efforts, and Reduces Residual stress in welding

Keywords— ANSYS FE model , Welding speed , Heat flux , Gap , Temperature.

1. INTRODUCTION

The welding process is an integral manufacturing procedure in many engineering and structural component, having a direct influence on the integrity of the components and their thermal and mechanical behaviour during service. Due to the high temperature introduced during welding and subsequent cooling of weld metal, welding can produce undesirable residual stress and the deformation on the component due to rupture of the welded joints. It is important interest to simulate the process of welding to delineate the ensuring the residual stress and deformation and predict the behaviour of welded structures. Some of the other identified effects are as Shrinkage, Inclusions, Segregation, Porosity, Surface defects. Reduces Residual stress in welding. The present work deals with the following main assumptions and features about the thermal model:

- a) The displacements of the parts, during the welding, do not affect the thermal distribution of the parts themselves;
- b) All the material properties are described till to the liquid phase of metal;
- c) Convection and radiation effects are considered;
- d) TIG methodologies for root and/or filling weld are modelled;

e) The ANSYS birth and death procedure is used and the CPU time was strongly reduced.

2. TYPES OF WELDED JOINTS

The welding joints are also different types like

- i. Fillet-joint
- ii. Butt joint
- iii. Lap joint

2.1. FILLET JOINT

Fillet welding is a type of joint used for welding pieces or plates in which the angle between them varies from 0 (zero) to 180 degrees. The strength of the fillet weld is in the thickness of the weld itself rather than the depth of penetration.

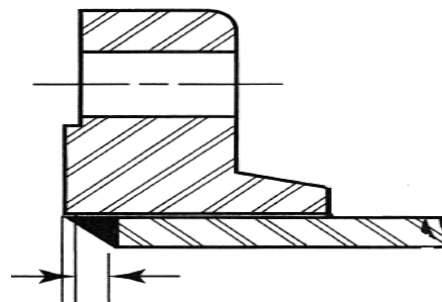

Figure 2.1.1 fillet Welding joint

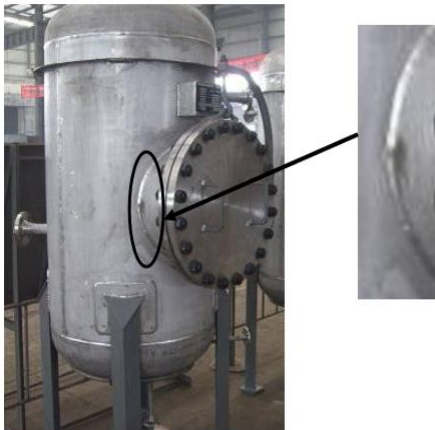

Figure 2.1.2 Welding joint used in pressure vessel

2.2. PROBLEMS OCCURS DURING WELDING

The welding process is an integral manufacturing procedure in many engineering and structural component, having a direct influence on the integrity of the components and their thermal and mechanical behaviour during service. Due to the high temperature introduced during welding and subsequent cooling of weld metal, welding can produce undesirable residual stress and the deformation on the component due to rupture of the welded joints. It is important interest to simulate the process of welding to delineate the ensuring the residual stress and deformation and predict the behaviour of welded structures. Some of the other identified effects are as Shrinkage, Inclusions, Segregation, Porosity, Surface defects.

2.3. OBJECTIVE

The objective of the current work is stated below

- The maximum stress, displacement and strain are to be calculated for curved plates being welded.
- The deformation due to the temperature variation is to be calculated.

3. Scope of paper

The scope of this study is as follows

- The material selected is AISI stainless steel.
- The effect of temperature is only to be studied.
- The considered case of the plate is curved plates.
- The material properties are adopted from previous studies carried out in the same area.

3.1. CAD MODELING FOR WELDING PLATE

In this case CAD modelling of curved plates is described using Solid Works. The Solid Works application is mechanical design automation software that takes advantage of the familiar Microsoft Windows graphical user interface. This easy-to-learn tool makes it possible for mechanical designers to quickly sketch ideas, experiment with features and dimensions, and produce models and detailed drawings. SolidWorks is a 3D mechanical CAD (computer-aided design) program that runs on Microsoft Windows and is developed by Dassault Systems. It integrates a broad range of mechanical CAD, design validation, product data management, design communication, and CAD productivity tools in a single, affordable easy to use package. One can go from concept to virtual prototype faster than ever thought possible with the desired quality using a single easy to use application. SolidWorks is so complete that one can progress from a product concept to a highly accurate virtual prototype without employing any other software. Figure 3.1.1 shows typical user interface of SolidWorks.

- A SolidWorks model consists of 3D solid geometry in a part or assembly document.
- Drawings are created from models, or by drafting views in a drawing document.
- Typically, you begin with a sketch, create a base feature, and then add more features to your model. (You can also begin with an imported surface or solid geometry.)
- You can refine your design by adding, editing, or reordering features.
- Associatively between parts, assemblies, and drawings assures that changes made to one document or views are automatically made to all other documents and views.
- You can generate drawings or assemblies at any time in the design process.
- With a Rear-view-compatible graphics card installed, you can display photo-realistic models and environments.
- Click Tools, Options on the main menu to display System Options and Document Properties.
- The Solid Works software saves your work for you with auto-recover. You can also choose to be reminded to save your work.

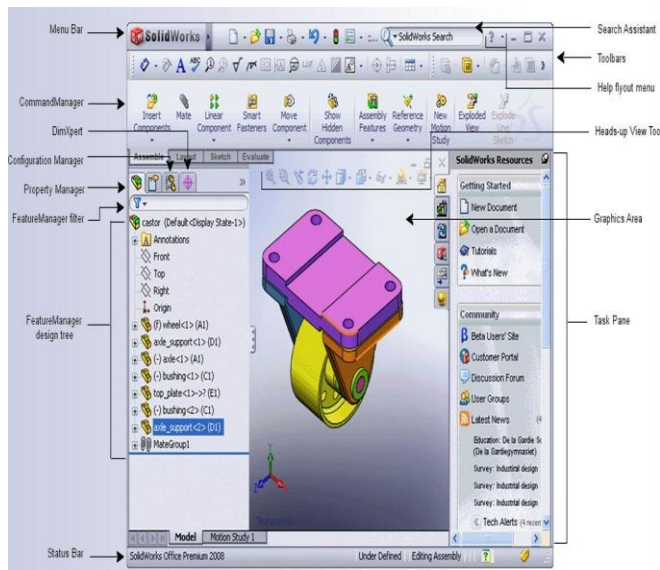

Figure 3.1.1 SolidWorks User Interface

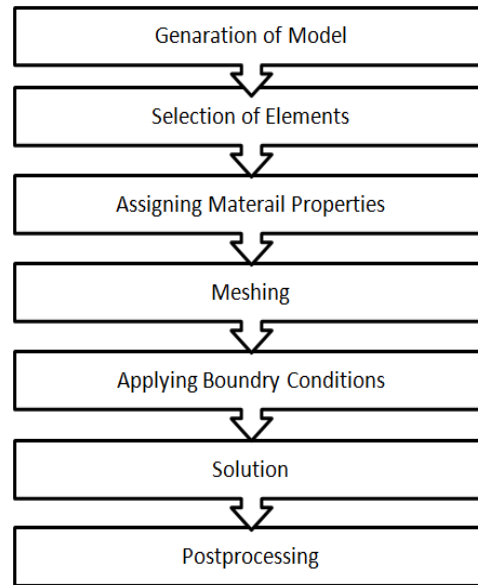

Figure 3.2.1 Flow chart of Steps in software analysis

3.2. FINITE ELEMENT ANALYSIS OF WELDING PLATE

The FEM is one such approximate solution technique. The FEM is a numerical procedure for obtaining approximate solutions to many problems encountered in engineering analysis. Mathematically, the structure to be analyzed is subdivided into a mesh of finite sized elements of simple shape. Within each element, the variation of displacement is assumed to be determined by simple linear or quadratic shape function & nodal displacements. For this the equations of equilibrium are assembled in a matrix form which can be easily be programmed & solved on a computer. After applying approximate boundary conditions, nodal displacements are found by solving the matrix stiffness equation. Once the nodal displacements are known, element stresses & strains can be calculated. For getting the solution in FEM analysis step by step procedure are required these procedure are mentioned below.

Present work uses ANSYS for FEM analysis of welding plate. ANSYS is widely used FEM analysis software both in academics as well as in industry. Using ANSYS one can perform various tasks of FE analysis and there is huge element library available to meet the user requirements of various type of analysis. There are two different user interfaces available i.e. ANSYS classic and ANSYS workbench. Traditionally, ANSYS classic is choice of analysts but of late ANSYS workbench is becoming popular with analysts. Present work used ANSYS classic version 14.2. After analysis, various results are reviewed such as stress, strain and deformation.

4. FEA of welding of curved plate

In the welding process high amount of heat is generated which causes change or deformation of the two parts being welded together. Thus to carry out the analysis of the parts being welded as in this case the welding of the curved plated both the thermal and the structural analysis is needed to be carried out. In this the major stresses are being generated due to the temperature change and the deformation occurs in the plates. Thus first we need to carry out the thermal analysis and then the structural analysis must be carried out.

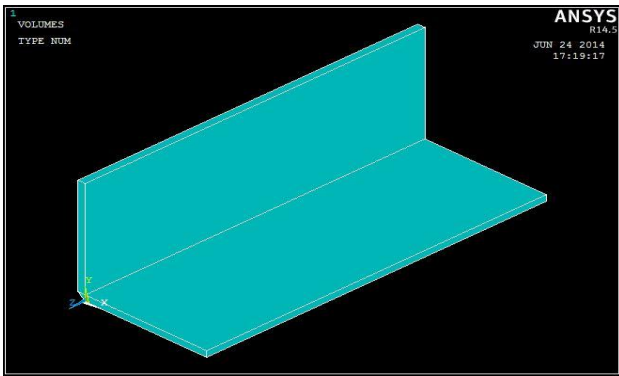

Figure 4.1 Model of the curved plate

4.1. Thermal Analysis

1. Generation of model

Based on the dimensions of the curved plate, the model is created in the solid work, as shown in Figure 3.2.1

2. Selection of Elements

The model is using two types of element i.e., SOLID 70 and SHELL 131 (ANSYS element library). The details of the selected elements are mentioned below.

i. Solid 70 (Brick 8node70)

SOLID70 has a 3-D thermal conduction capability. The element has eight nodes with a single degree of freedom, temperature, at each node. The element is applicable to a 3-D, steady-state or transient thermal analysis. The element also can compensate for mass transport heat flow from a constant velocity field.

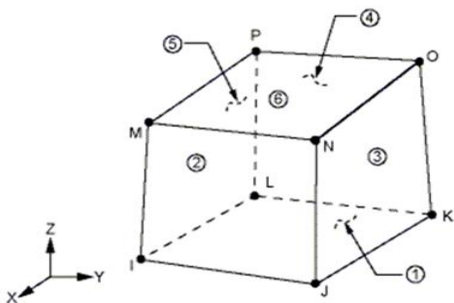

Figure 4.1.1 Geometry of solid70 element

ii. Shell 131(3 D 4node 131)

SHELL131 is a 3-D layered shell element having in-plane and through-thickness thermal conduction capability. The element has four nodes with up to 32 temperature degrees of freedom at each node. The conducting shell element is applicable to a 3-D, steady-state or transient thermal analysis. SHELL131 generates temperatures that can be passed to structural shell elements in order to model thermal bending.

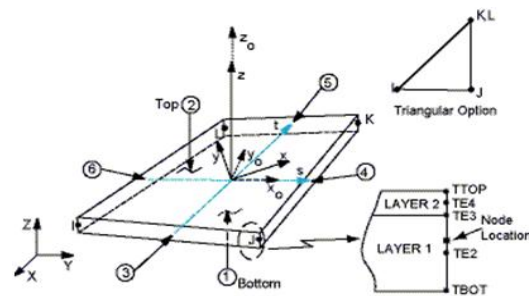

Figure 4.1.2 Geometry of Shell131 element

4.2. MESH

As mentioned above the solid70 and shell131 element used. The meshing of the model is done by using the hex shape elements. In these the fine meshing were done for getting the accuracy in the solution.

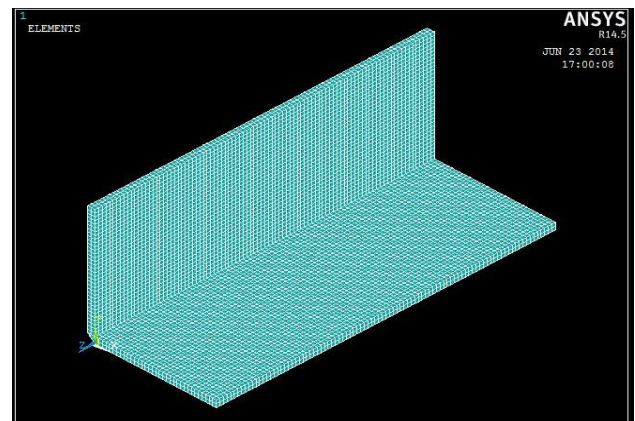

Figure 4.2.1 Meshing of the welded plates

4.3. BOUNDARY CONDITIONS FOR FEA

Due to the heat applied to the plate it gets liberated to the surrounding through the mode of convection. For that

purpose the convection were applied to the plate as the boundary condition.

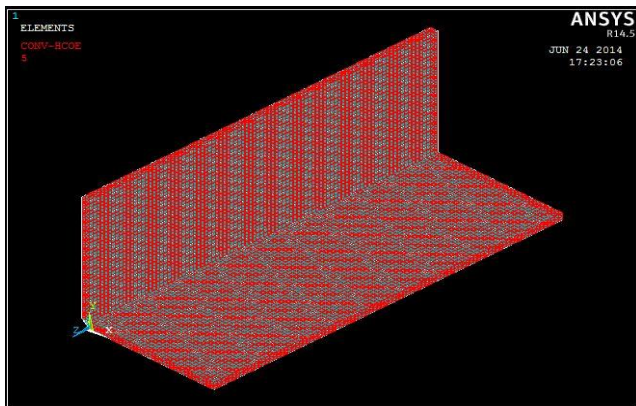

Figure 4.3.1 Boundary condition applied to the thermal welded plates

4.4. Load

For obtaining the effect of the welding temperature the heat flux is applied as load on the welded curved plate model.

4.5. STRUCTURAL ANALYSIS

To carry out the structural analysis the thermal profile obtained in the table 5.1 is taken as loads acting on the welded plates. Thus the need of material properties and other relevant details get avoided.

1) Boundary condition

The Figure 5.2 shows the application of the boundary conditions to the model. The displacement at both the end of the plate is zero i.e. $U_x=U_y=U_z=0$.

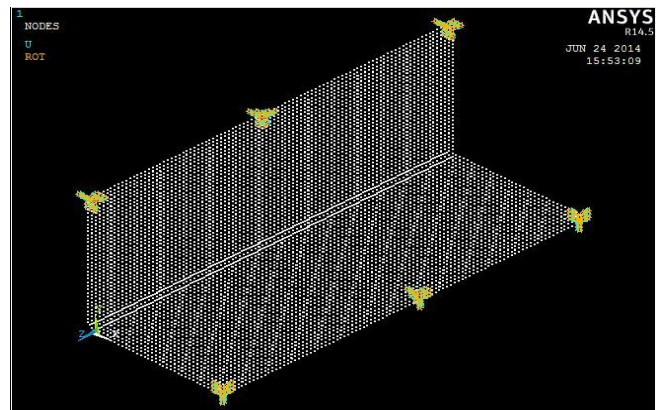

Figure 4.5.1 Boundary condition applied to the structural welded plates

2) Load

The temperature profile obtained from the thermal analysis is taken as the load for the structural analysis

3) Solution

After applying the load there is need to check the deformation, stress, strain occurred on the curved plate for that purpose in ANSYS the solution step is employed.

4) Post processing

In post processing the effect of welding in terms of displacement, stress, strains were found out. For the further results the heat flux and the speed were varied.

5. RESULT AND DISSCUTION

5.1 Effect of process parameter on Welding

In this work, two cases with different combinations of parameters have been studied.

The two cases are as described in table 5.1 below. Each parameter was investigated with low, medium, and high values of heat flux and speed.

Table 5.1.1 Changing parameter of Heat flux and Speed

Case	Study	Heat Flux	Speed
1	Effect of Heat Flux	Changed*	Medium
2	Effect of Speed	Medium	Changed*

Thermo-mechanical responses such as residual stresses, strains, and displacements were obtained from the finite element elasto-plastic analysis. The responses were taken along the vertical path and horizontal path. For all two cases, the responses at each node along the path were plotted over the nodes along the cross sections.

The following table represents the case of varying parameters along horizontal path.

Table 5.1.2 Values of parameters

Sr. No	Parameter variables	Heat Flux (w/m ²)	Speed (mm/s)
1	Low	1.61x10 ⁸	1
2	Medium	1.82x10 ⁸	2
3	High	2.15x10 ⁸	10

5.2 EFFECT OF HEAT FLUX

The change in the heat flux due to welding there is considerable effect on the displacement, stress, elastic strain and plastic strain along the vertical path and horizontal path of the curved plate.

A. ALONG VERTICAL PATH

The parameters like displacement, stress, and strain changes along the vertical path, are calculate and the results of the same are discussed below.

5.2.1 Displacement

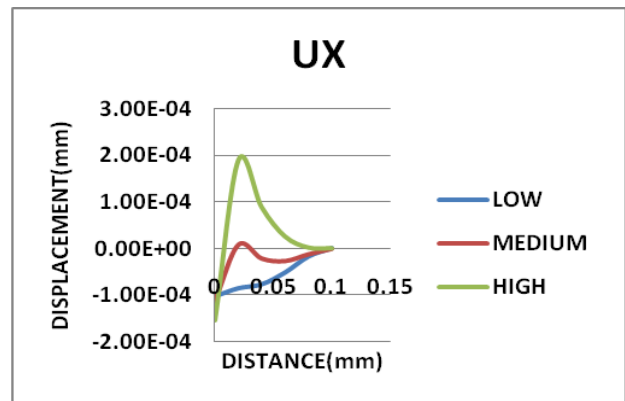

Graph 5.2.1.1 Effect of heat input on displacement along X direction

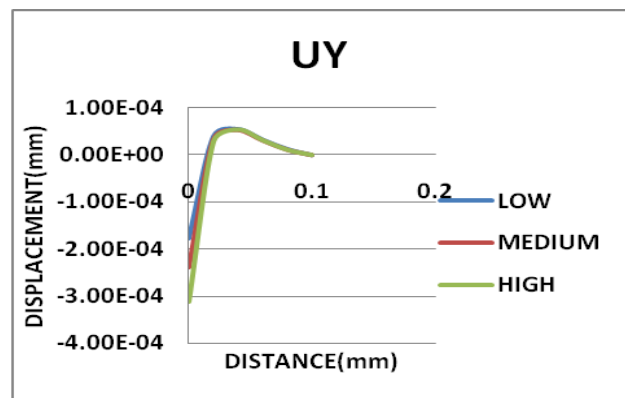

Graph 5.2.1.2 Effect of heat input on displacement along Y direction

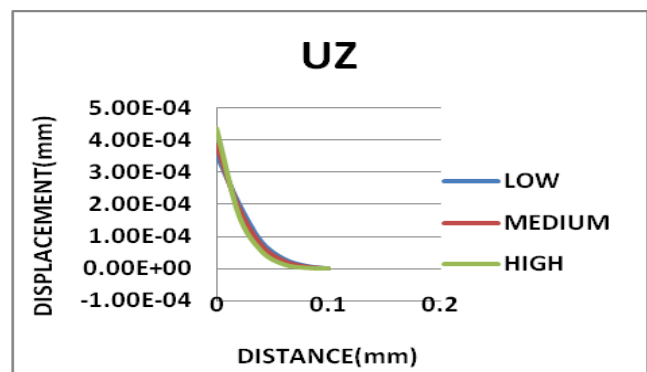

Graph 5.2.1.3 Effect of heat input on displacement along Z direction

As shown in figures 5.2.1.1, 5.2.1.2 and 5.2.1.3 displacements in X direction of the vertical plate is more sensitive to heat input, from figure it is observed that maximum displacement occurs at 30 mm cross section which is in the heat affected zone. The displacement obtained in the vertical path is more as compared to the displacement in the horizontal path.

5.2.2 Elastic Strain

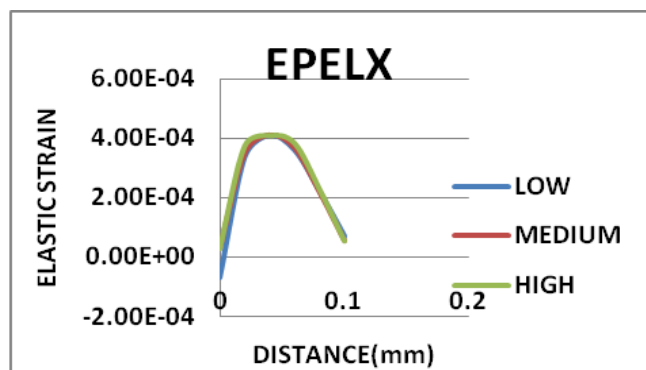

Graph 5.2.2.1 Effect of heat input on elastic strain along X direction

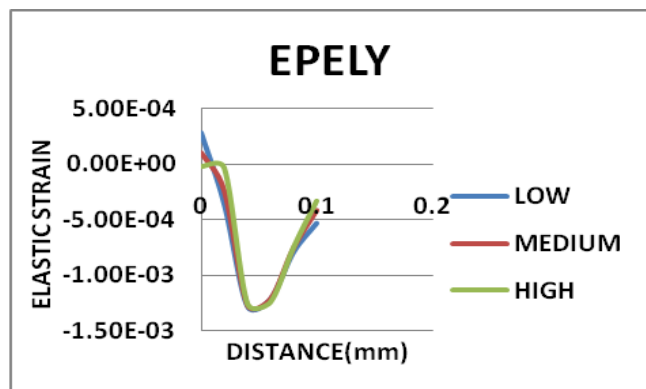

Graph 5.2.2.2 Effect of heat input on elastic strain along Y direction

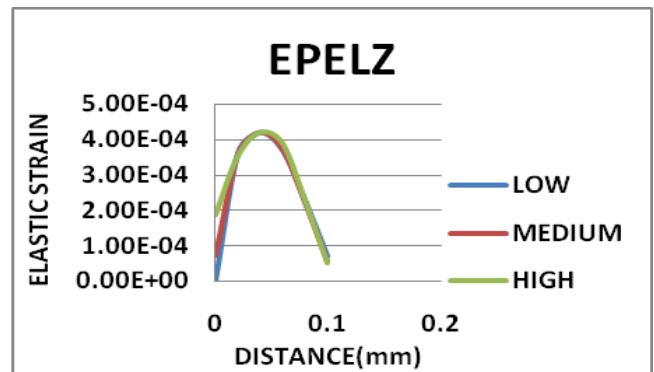

Graph 5.2.2.3 Effect of heat input on elastic strain along Z direction

The above figures 5.2.2.1, 5.2.2.2 and 5.2.2.3 shows that X elastic strain, Y elastic strain and Z elastic strains are sensitive to heat input. As heat input changes strain changes respectively.

5.2.3 Plastic Strain

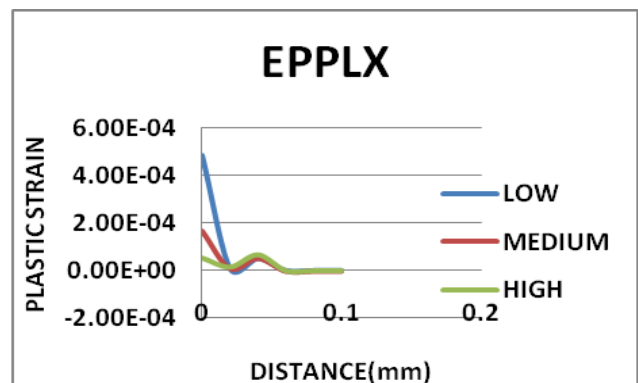

Graph 5.2.3.1 Effect of heat input on plastic strain along X direction

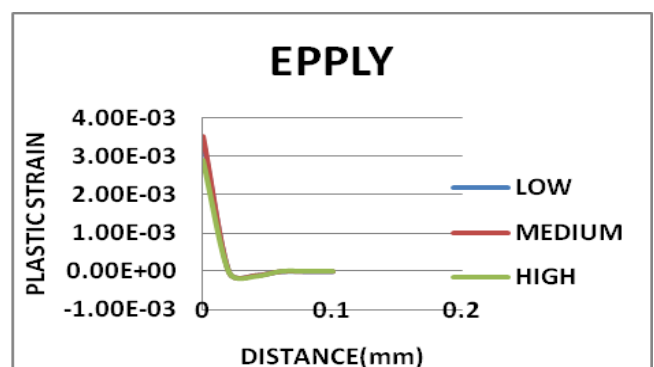

Graph 5.2.3.2 Effect of heat input on plastic strain along Y direction

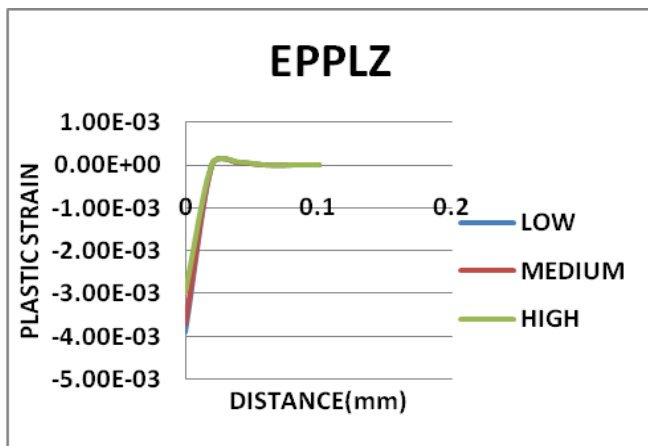

Graph 5.2.3.3 Effect of heat input on plastic strain along Z direction

Figures 5.2.3.1, 5.2.3.2 and 5.2.3.3 shows that heat input do not have significant effect on plastic strain. Plastic strain value is Maximum at horizontal zone and Minimum at vertical zone in the weld zone and becomes zero at another cross section.

5.2.4 Stress

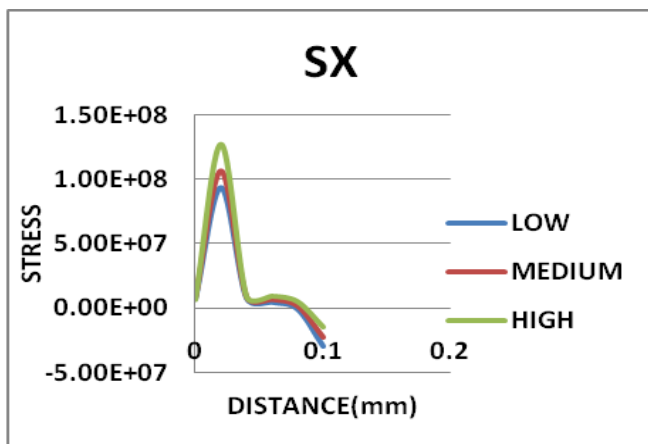

Graph 5.2.4.1 Effect of heat input on stress along X direction

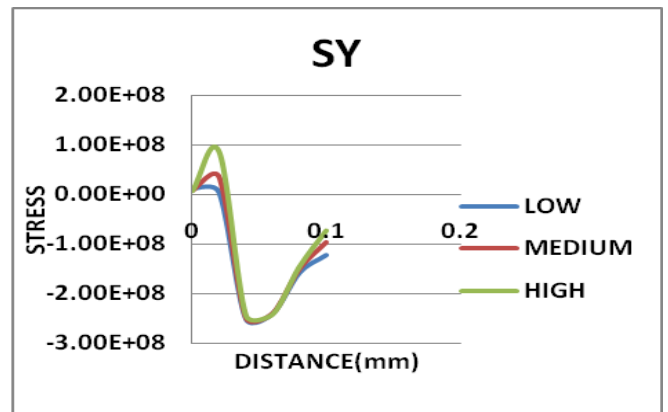

Graph 5.2.4.2 Effect of heat input on stress along Y direction

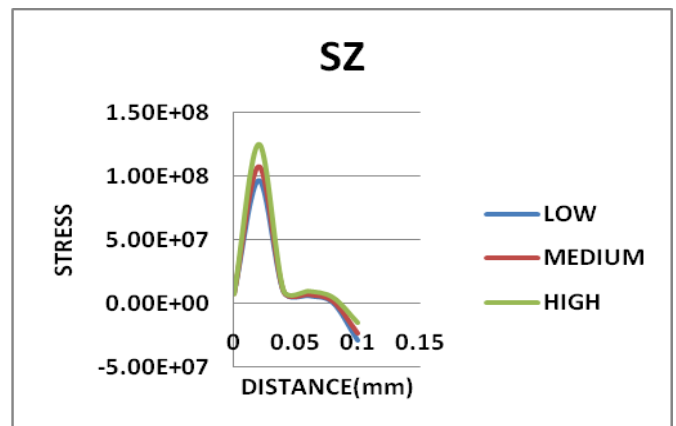

Graph 5.2.4.3 Effect of heat input on stress along Z direction

Figures 5.2.4.1, 5.2.4.2 and 5.2.4.3 show that stress value decreases as heat input increases. This is due to fact that we cannot consider cooling time in the solution. As we can see from the graph that Y-stress and Z-stress in the vertical plate is more sensitive to the heat input as compare to X-directional stresses.

As heat input increases the stresses decreases, this is due to the fact material properties such as young's modulus decreases as temperature in the material increases. As the heat input increases temperature generates in the plate increases and thus the stress generated decreases"

The results showed that the welding heat input has significant effect on the welding responses. When the heat input increases, the responses such as displacements, strain increase. An increase of 12 % of heat input results in

a significant increase in the Z-displacement (8%), and X-Elastic strain (60 %)and Z-Elastic strain (98 %).

5.3 Effect Of Speed

The change in the speed during welding has a considerable effect on the displacement, stress, elastic strain and plastic strain along the vertical path and horizontal path of the curved plate. The detailed discussion will be carried out on the effect of the speed below.

A. ALONG VERTICAL PATH

The parameters like displacement, stress, and strain changes along the vertical path, are calculate and the results of the same are given below.

5.3.1 Displacement

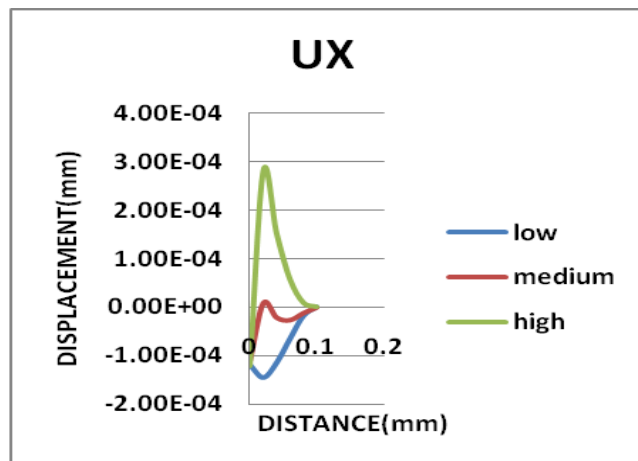

Graph 5.3.1.1 Effect of speed on displacement along X direction

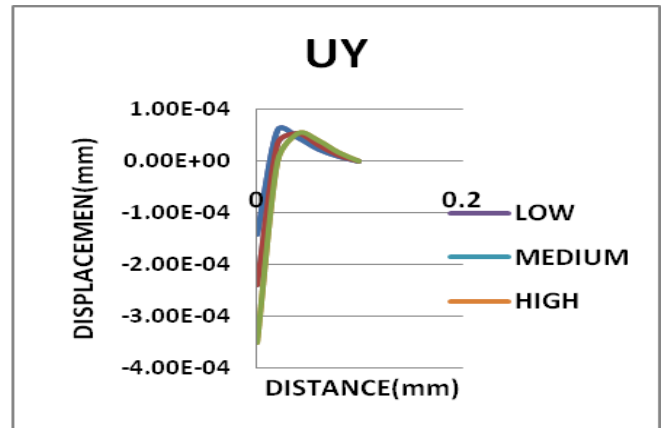

Graph 5.3.1.2 Effect of speed on displacement along Y direction

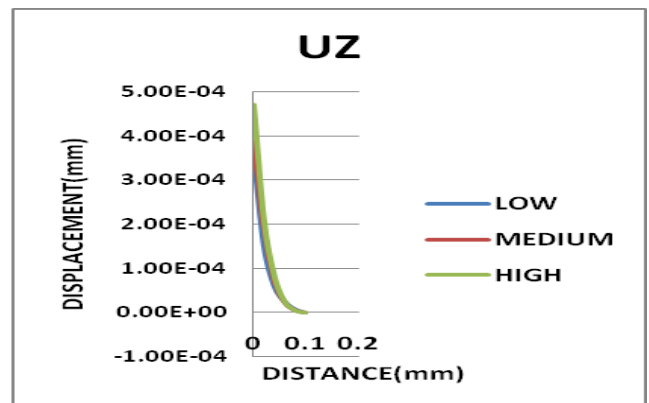

Graph 5.3.1.3 Effect of speed on displacement along Z direction

As shown in figures 5.3.1.1, 5.3.1.2 and 5.3.1.3 displacements in X direction of the vertical plate is more sensitive to speed as compared to other directional displacement i.e. Y and Z displacement, from figure it is observed that maximum displacement occurs at 30mm cross section which is in the heat affected zone. The displacement obtained in the vertical path is less as compared to the displacement in the horizontal path.

5.3.2 Elastic Strain

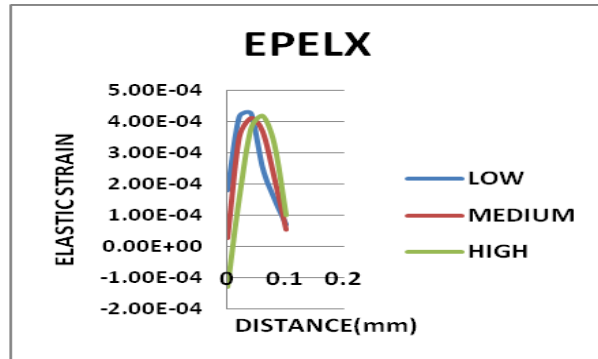

Graph 5.3.2.1 Effect of speed on elastic strain along X direction

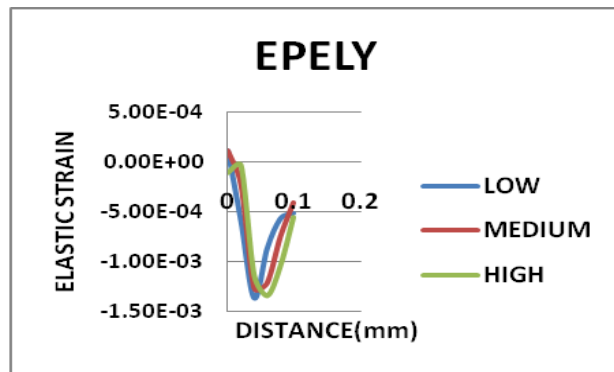

Graph 5.3.2.2 Effect of speed on elastic strain along Y direction

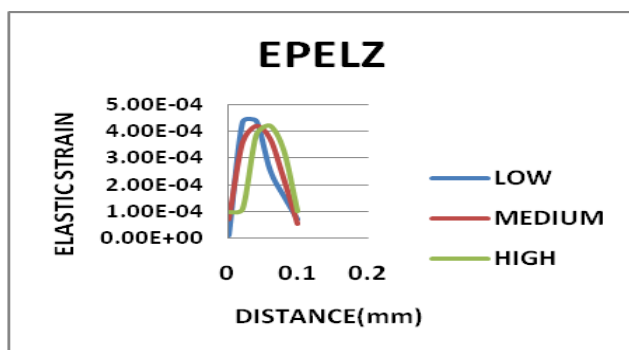

Graph 5.3.2.3 Effect of speed on elastic strain along Z direction

The above figures 5.3.2.1, 5.3.2.2 and 5.3.2.3 show that Yelastic strain and Z elastic strains are sensitive to speed. As speed changes strain changes respectively.

5.3.3 Plastic Strain

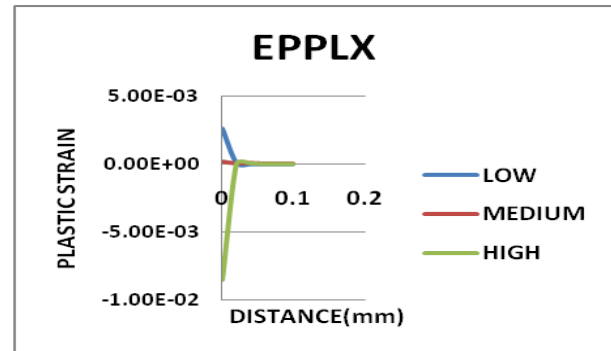

Graph 5.3.3.1 Effect of speed on plastic strain along X direction

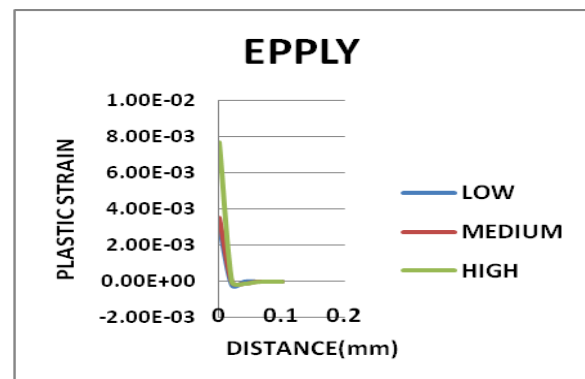

Graph 5.3.3.2 Effect of speed on plastic strain along Y direction

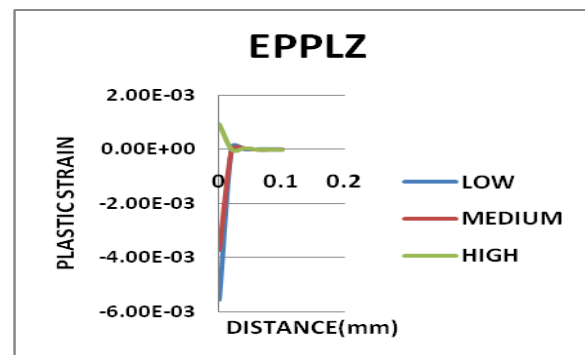

Graph 5.3.3.3 Effect of speed on plastic strain along Z direction

Figures 5.3.3.1, 5.3.3.2 and 5.3.3.3 shows that speed do not have significant effect on plastic strain. Plastic strain value is maximum in the weld zone and becomes zero at another cross section.

5.3.4 Stress

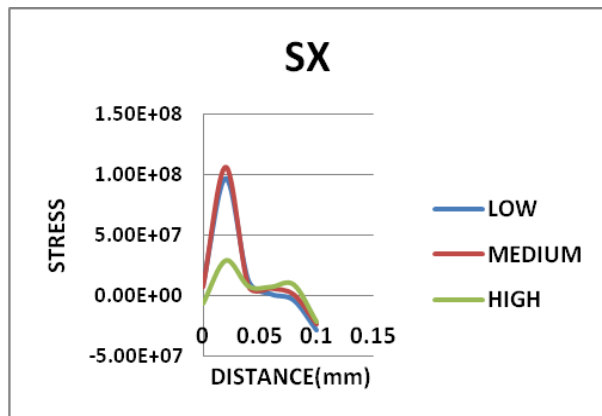

Graph 5.3.4.1 Effect of speed on stress along X direction

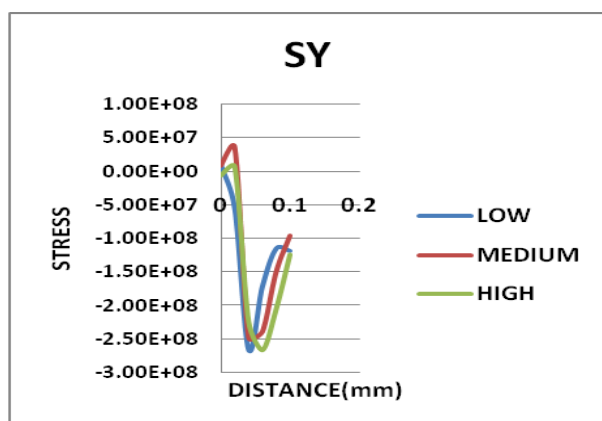

Graph 5.3.4.2 Effect of speed on stress along Y direction

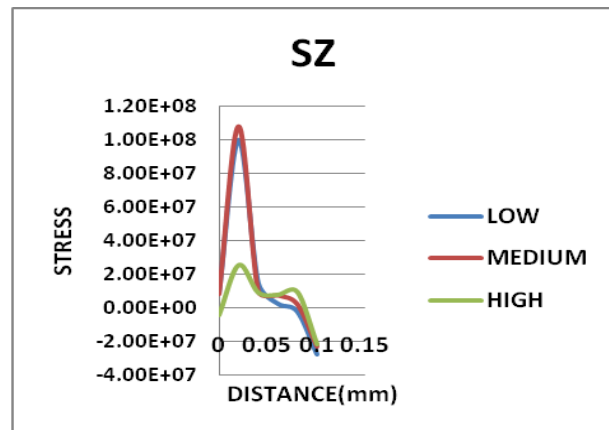

Graph 5.3.4.3 Effect of speed on stress along Z direction

Figures 5.3.4.1, 5.3.4.2 and 5.3.4.3 show that stress value decreases as speed increases. This is due to fact in the solution cooling time is not considered. By observing the graph the Y-stress and Z-stress in the vertical plate is more sensitive to the speed as compare to X- directional stresses.

As speed increases there is considerable amount of stresses decreases, this is due to the fact material properties such as young's modulus decreases as temperature in the material increases.

The results showed that the welding speed has significant effect on the welding responses. When the speed increases, the responses such as displacements, strain increase. An increase of 50% of speed results in a significant increase in the X-displacement by 6%, Z-displacement by 8%, Z-Elastic strain by 24% and Z-plastic strain by 49%.

The results obtained in the above methodology can be summarized or compared as shown in the table below

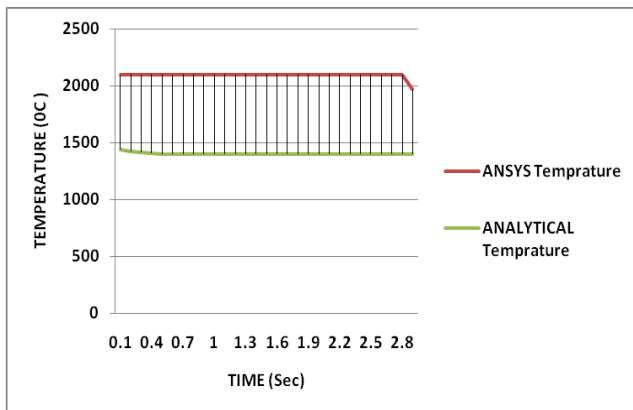

Graph 5.3.1 comparison between Analytical and ANSYS temperature

6. CONCLUSIONS FOR EFFECT OF DIFFERENT PARAMETER ON RESIDUAL STRESS

Complex welding phenomena can be simulated using a commercial Finite Element package, viz., ANSYS. Special features of birth and death element has been used to simulate the deposition of weld material

- 1) Based on the simulation result, distortion or shrinkage of weldment can be predicted. Thus the experimental analysis, which might be costly, can be avoided.
- 2) Heat input and welding speed have significant effect on the weld response. The conclusion that can be drawn from the simulation result are as follows
- 3) An increase of 12 % of heat input results in a significant increase in the Z-displacement (8%), and X-Elastic strain (60 %) and Z-Elastic strain (98 %).
- 4) When the speed increases, the responses such as displacements, strain increase. An increase of 50% of speed results in a significant increase in the X-displacement by 6%, Z-displacement by 8%, Z-Elastic strain by 24% and Z-plastic strain by 49%

7. FUTURE SCOPE

The current study only focuses on the software techniques to find out the temperature of the plate thus, the future study can be carried out by setting up an experimental model for calculating the temperature of the same.

8. REFERENCES

1. Andrea Capriccioli, Paolo Frosi. "Multipurpose ANSYS FE procedure for welding processes simulation". ENEA CR Frascati, Via Enrico Fermi 45, 00044 Frascati, Italy, Fusion Engineering and Design 84 (2009) 546-553.
2. C. Heinze, C. Schwenk & M. Rethmeier. "Numerical calculation of residual stress development of multi-pass gas metal arc welding under high restraint conditions" aBAM Federal Institute for Materials Research and Testing, Division 5.5 "Safety of Joined Components", Unter den Eichen 87, 12205 Berlin, Germany. Materials and Design 35 (2012) 201-209.
3. L.-E. Lindgren "Numerical modelling of welding". Received 18 February 2004; received in revised form 4 August 2004; accepted 6 August 2005. Comput. Methods Appl. Mech. Engrg. 195 (2006) 6710-6736
4. M. Abid & M. Siddique "Numerical simulation to study the effect of tack welds and root gap on welding deformations and residual stresses of a pipe-flange joint" Graduate Student, Faculty of Mechanical Engineering, GIK Institute of Engineering Sciences and Technology, Topi, NWFP, Pakistan. International Journal of Pressure Vessels and Piping 82 (2005) 860-871
5. Dean Deng, Hidekazu Murakawa "Prediction of welding distortion and residual stress in a thin plate butt-welded joint" Joining and Welding Research Institute, Osaka University, 11-1, Mihogaoka, Ibaraki, Osaka 567-0047, Japan. Computational Materials Science 43 (2008) 353-365
6. Avinash Kharat, V. V. Kulkarni "Stress Concentration at Openings in Pressure Vessels - A Review". Research Scholar, Dept. of Production Engineering, K. I. T.'s College of Engineering, Kolhapur, Maharashtra, India. International Journal of Innovative Research in Science, Engineering and Technology Vol. 2, Issue 3, March 2013
7. Vishnu V.S, Nadeera M & Joy Varghese V.M "Numerical Analysis of Effect of Process Parameters on Residual Stress in a Double Side TIG Welded Low Carbon Steel Plate". Dept. Of CIM,

T.K.M College of engg./ Kerala University, India.
IOSR Journal of Mechanical and Civil Engineering
(IOSR-JMCE) e-ISSN: 2278-1684, p-ISSN: 2320-
334X PP 65-68

8. Wenge Zhang , Xuedong Chen, Tiecheng Yang, Jianrong Li & Jilin Yu "Stress analysis and safety assessment for nozzle welding area enduring high pressure and high temperature". Department of Mechanics and Mechanical Engineering, University of Science and Technology of China, Hefei 230027, Anhui, China. Journal of Pressure Equipment and Systems 4 (2006) 86-90.
9. B. Brickstad", B. L. Josefsonb "A parametric study of residual stresses in multi-pass butt-welded stainless steel pipes". International Journal of Pressure Vessels and Piping 75 (1998) 11-25.
10. Ho-Sung Lee, Jong-Hoon Yoon, Jae-Sung Park "A study on failure characteristic of spherical pressure vessel". KSLV Technology Division, Korea Aerospace Research Institute, 45 Eoeun-Dong, Yuseong-Gu, Daejeon, 305-333, Republic of Korea. Journal of Materials Processing Technology 164-165 (2005) 882-888.
11. Harshal B Sonawane, E R Deore "FINITE ELEMENT MODEL FOR THE EFFECT OF HEAT INPUT & SPEED ON RESIDUAL STRESS ". International Journal of Mechanical Engineering Robotics and Research, Volume 3, Issue-3, July 2015.
12. D.Devakumar, D. B Jabaraj "Research on Gas Tungsten Arc Welding of Stainless Steel - An Overview". International Journal of Scientific & Engineering Research, Volume 5, Issue 1, January-2014 1612 ISSN 2229-551.

BIOGRAPHIES



Prof Vijay L Kadlag completed his Master degree in Mechanical (Production) and presently working as Professor and HOD of workshop at the Department of Mechanical of SVIT COE CHINCHOLI-42210, Maharashtra (INDIA). His research interest includes Mechanical Design, FEA, and Pressure Vessel Design etc



Kiran D Gaidhane is a M.E (Design Engineering) Pursuing from SVIT COE CHINCHOLI-42210, Maharashtra (INDIA). He is having overall 7 year experience in Automobile Industry. His major interests are in Manufacturing Science, Production Engg, Fabrication, welded structures