

HAND GESTURE FOR MULTIPLE APPLICATIONS

Janani.K, Assistant Professor

Renuka.N¹, Shyalu .S², Ramalakshmanan .B³, Selvakumar. S⁴

¹²³⁴student(BE), Department Of Electrical and Electronics Engineering,

Sri Krishna College of Technology

Coimbatore, Tamilnadu

Abstract - In today's world where every operations performed by human are getting simple, in order to make it simpler I present an innovation which makes use of HAND GESTURE. Hand Signal Transceiver system will be introduced for the medical purpose. The transceiver will detect several hand gestures and then sent out the corresponding information which will be received by another transceiver and will be displayed on a LCD screen. System design will cover both hardware and software implementation of wireless system. The hardware part is mainly based on PIC 16F877A controller, GSM, Accelerometer. The biggest advantage is that it is cost effective.

Key words- Gesture based Transceiver, accelerometer, system for patient emergency in hospitals, system for blind and dump people, wireless communication with use of hand gesture.

1.INTRODUCTION

Safety was a primary concern for the visually impaired in the past when navigating in an unfamiliar urban environments. Hence the people with disability has lost the independence to navigate in environment. The blind people can use sensors which are provided a better way to reach destination and detect obstacles on ground. With the recent advances in today's technology [2], it is possible to support to blind people. Example can be a smart phone, which cannot be a help to the blind and partially sighted people needed in their daily life.[5] Another example refers to electronic -oriented aids, is the laser (or) ultrasonic, in this energy waves are emitted ahead, which is reflected from the obstacles in the path of the people with disabilities and is detected by a matching sensor.

In recent days there has been a lot of electronic aids designed to help the blind people to navigate safely and independently.[1] To reach the destination and location of blind person and these are based on the solution relied on GPS (or) GSM technology. These system are to be used in outdoors in order to trace the exact location of the blind people, whenever there is an emergency. The location is traced to enhance the means to assist blind person to navigate quickly and safely in a risky environment.



Fig 1 : Hand Gesture Kit

Hand Gesture recognition is performed through a hand curvature method in which involves finding the boundary movements of the hand[3]. The main scope of this paper is to develop a low cost intelligent system capable of encouraging the blind and visually impaired people to walk independently without the help of sighted people. The system is a GPS/GSM based so that it takes the advantage of GSM network such as popularity and cost effectiveness. GPS/GSM module has been used in different areas of where impaired people would navigate, such as the navigation of vehicles and aid to prevent visually impaired pedestrian enabling people to avoid obstacles and reach the destination. Thus here rather for the vehicle usage it gives an extra aid for the blind to assist easily with the use of GSM tracking system.

2.LITERATURE SURVEY

RafiqulZamanKhan and Noor Adnan Ibrahim(2012) applied multivariant Gaussian distribution to recognise hand gesture using non- geometric features.The input hand image is segmented using two different methods ,skin color based segmentation by applying HSV color model and clustering based thresholding techniques.some operations are performed to capture the shape of the hand to extract hand feature.The modified Direction Analysis Algorithm are adopted to find a relationship between stastical parameters from data and use to compute object slope and trend by finding the direction of the hand gesture.

Gurubaran,GowrisankarKasilingam, Mritha Ramalingam (2014), proposed an interacting technique for real time tracking of hand capturing gestures through a web camera and Intel Pentium based personal computer.This system is implemented without the use of sophisticated image processing algorithm and hardware.It uses coin sized accelerometer sensor for manipulating the application.Hand gesture techniques is done in real time environment using vision based techniques.

Stern(2013),developed a smart white cane, called blindspot that combines GPS technology ,social networking and ultrasonic sensors to help visually impaired people to navigate public spaces. The GPS detects the location of the people and alerts the hospitals for their emergency. The GPS does not show the efficiency in tracking the location of people .Inorder to be more accurate we go for GSM.

Siddharth RautaRay (2011), had developed a smart stick using laser sensors to detect the obstacles. Obstacles are detection was signalized by a high pitch BEEP. The design of laser cane is very simple and intuitive. The stick detect only obstacles ,but not provide cognitive and psychological support.

Alejandro R.Garcia Ramirez and Renato Fonseca Livramento da Silvaetal(2012) designed an assistive technology device called the electronic glove to serve as a mobility aid for blind and visually impaired people. The author implements the glove with an ergonomic design and an embedded electronic system, which fits inside the handle of the glove. The system was designed using hepatic sensors to detect the obstacle above the waist line. It works in such a way when the obstacles is

detected the glove vibrates or makes a sound. This system only detects obstacles above the waistline.

Shruti Dambhare and A.Sakhare (2011) designed an artificial vision and object detection withreal-time assistance via GPS to provide a low cost and efficient navigation aid for blind which gives a sense of artificial vision by providing information about the environmental scenario of static and dynamic objects around them.

In 2014, Viraj Sinde, Tushar Bacchav, Jitendra Pawar and Mangesh Sanap developed “ Hand Gesture recognition system using camera” they focus on using pointing behaviours for a natural interface to classify the dynamic hand gesture, they developed a simple and fast motion history image based system. This paper presents low complexity and gesture recognition complexity and more suitable for controlling real time computer system. It is applicable only for the application of power point presentation.

In 2012, Ram Rajesh J, Nagarajunan D and Aarthi R, “Remotely controlled power point presentation navigation using hand gestures” developed the system which slides of power point presentation without using any marker and gloves. After detecting hand calculation is used for hand figures. If the figures are not stretched properly while making a gesture then application does not work properly.

3.EXISTING SYSTEM

Many various system have been developed that are being controlled by gesture. These system consists of games, sign language recognition all these system can be controlled by facial gesture.

From the survey, we analyse that there certain areas can be enhanced in order to have a reliable and efficient blind stick for visually impaired people. Various problems identified, for example using IR sensors for obstacle detection is not good enough due to range of detection which is shot compared to other proximity sensor. This type of sensor detect only the near object. This might lead to accidents when there are vehicles that travel in high speed. Hence electronic stick is not assisting the blind people.

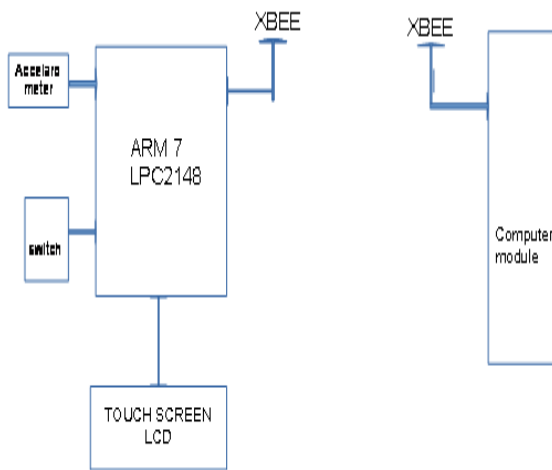

Fig 2 : Existing system

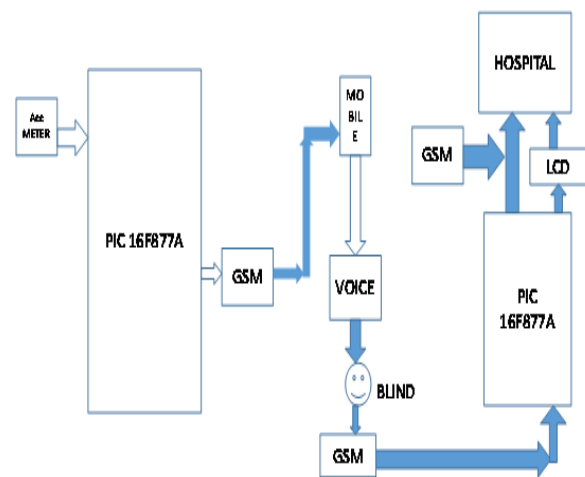

Fig 3 : Proposed system

The use of GPS technology brings in different features. GPS for navigation technique for outdoor and indoor does not differ a normal vehicle. Moreover blind people might also have difficulties on tracking of range obstacle within them via vibrations. It will be very much advanced if there is voice signal giving information on the distance of obstacle within the blind people in the form of voice.

4. PROPOSED SYSTEM

The proposed system is a new technique which is where hand gestures are captured using accelerations and acts as the receiver channel. The received signal is sent to PIC microcontroller which controls and captures the signal. The microcontroller PIC 16F877A is mostly commonly used. It is of low cost. The captured gesture is sent to the mobile phone using GSM which is wireless mode of transmission. These GSM message are sent to nearby hospitals stating that people are in danger. The received message will be displayed on the LCD screen which would be placed in the hospital.

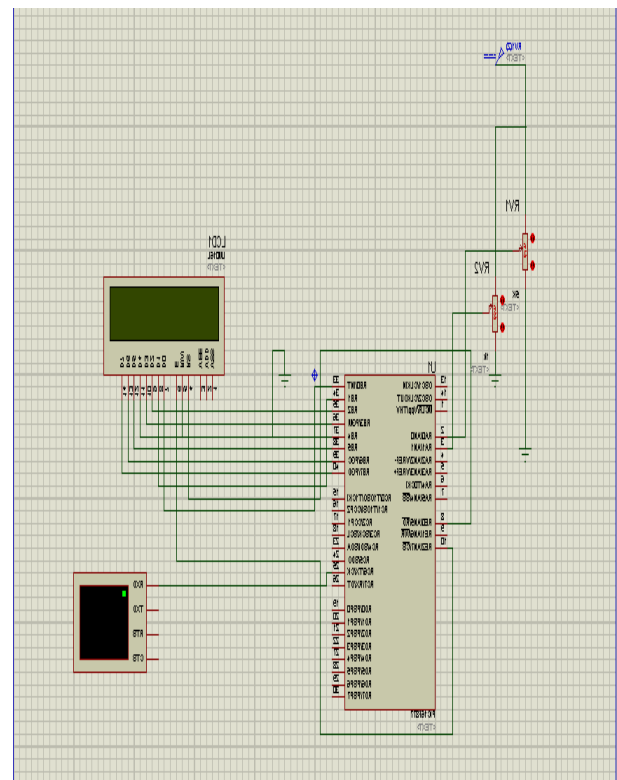

Fig 4 : Circuit diagram

5. CONCLUSION AND RESULT

Thus the system has been used to receive the data from the sensing devices and are made to be received by the GSM module . We have integrated the ultrasonic, accelerometer sensor data in order to detect obstacles ,

and to obtain more detailed regarding the blind's environment . Evaluations of the system that we have developed have been conducted by attaching the prototype to the handle of the glove. The experimental results have shown the usefulness of the system in allowing blind people to move independently, safely and quickly among obstacles and hazardous place.

6.REFERENCE

[1]. Parth B.Panchal , Vimal H.Nayak, "A Hand Gesture Based Transceiver System for Multiple Application" *IEEE sponsored 2nd International Conference on Electrical and Electronics System* , vol.8, no.15,Sep 2015.

[2]. Renqiang Xie , Xia Sun, Xiang Xia , Juncheng Cao, "Similarity Matching – Based Extensible Hand Gesture Recognition" , *IEEE Sensor Journal* , vol.15, no.6, June 2015.

[3]. Abdel Ilah Nour Alshbatat , "Automated Mobility And Orientation System for Blind or Partially Sighted People" , *International Journal on Smart Sensing and Intelligent System*, vol.6, no. 2, April 2013.

[4]. Pratik Bhatt , Deval Mehta , Nirav Faraswami , " Appartus and Method for Gesture Recognition" ,*Gujarat Technological University*, May 2012.

[5]. S Sadhana Rao , "Sixth Sense Technology",*IEEE International Conference on Communication and Computational Intelligence* ,Dec 2010.

[6]. B .Yi , F.C. Harris Jr., L. Wang and Y, Yan , "Real -Time natural Hand Gestures" , In proceeding of *IEEE computing in Science and Engineering* , Jan 2005.

[7]. S. S. Rautarray and A. Agarwal, "A Novel Human Computer Interface Based On Hand Gesture Recognition Using Computer Vision Techniques" , Mar 2009.

[8]. Viraj Shinde , Tushar Bacchav , Jitendra Pawar and Mangesh Sanap "Hand Gesture Recognition System using camera " , *International Journal of Engineering Research &Technology(IJERT)*,Vol.3 ,issue 1,January -2014.

[9]. Ram Rajesh j, Nagarjunan D, and Aarthi R. "Remotely controlled Power point presentation navigation using hand gesture " ,*Proc.of the Intl,Conf on*

Advances in Computer ,Electronics and Electrical Engineering, 2012.

[10]. Ahmed Elgammal , Vinay Shet ,Yaser Yacoob,Larry S.Davis .Learning Dynamics for Exemplar – based Gesture Recognition .*Inproceedings of the fifteenth International Conference on Computer vision*.