

Wireless Sensor Network Based Precision Green House Management System

G.Gnanavel¹, G.Ezhilarasan², N.Pavithra³

Assistant professor^{1,2}, PG scholar³

Department of EEE

V.R.S. College of engineering, Villupuram

gnanavel1982@gmail.com¹, gkar12345@yahoo.com², pavithra24swamy@gmail.com³

Abstract – Precision Green house management based agriculture is a combination of integrated information and production-based farming system that is designed to increase long term site-specific farm production efficiency and profitability while minimizing unintended effects on green house environment. It requires intensive sensing of the climate conditions at ground level and rapid communication of data to the central repository. Wireless sensor network is an emerging field that can be used to monitor and control the agriculture parameters in order to make intelligent automated agriculture system inside the green house. The system basically comprises of CPU for monitoring the data in LABVIEW platform and Zigbee module along with PIC microcontroller to establish wireless communication between two distant locations. The main purpose of the work undertaken in this paper is to sense, monitor and control the temperature, humidity and irrigation in the greenhouse from remote location using the Zigbee technology at low cost. In the present work the data from sensing node after amplification is fed to ADC and then to the microcontroller. This is then connected to the Zigbee module which transmits the data to the Zigbee module at the other end. It reads the data and displays on to the host computer through Labview and the control sequence is generated to control the green house parameters from the control room wirelessly.

Key Words: Green House, Precision Farming, Wireless Monitoring and Control, Zigbee

1. INTRODUCTION

The agricultural growth in future would increase immensely if improvements are made in the productivity of diversified farming systems with specific focus on regional specialization and sustainable management of natural resources. In order to diversify agriculture, agro processing and other value added activities play a pivotal role. Climatological condition monitoring is one of the most

important aspects in agricultural production that has a direct impact on the productivity and maintenance of crop. A huge loss occurs every year damage of crops by various diseases caused by improper climatic conditions. Deployment of intelligent sensor nodes, on the field, promises a wide range of new applications like plant growth monitoring and also monitoring of various environmental conditions that influences agricultural productions tremendously and many have used the wireless sensor nodes for the same purpose. The sensing technique allows acquisition of soil and crop information, communication and identification of environmental changes which can have devastating effects on the farm yield. With the help of that information at regular time intervals, the irrigation and climatic conditions inside the greenhouse can be controlled using automated actuation devices to increase the overall productivity.

Greenhouse is the advanced facility available in which we can control the climate to increase plant growth and avoid the effect of season changes on the plants. Greenhouse is playing a significant role in the production of out-of-season fruits, flowers and vegetables as well as high value and sensitive plants like capsicum. The purpose of greenhouse environmental control is to get the best climatic conditions (controlled temperature, humidity, light and level of carbon dioxide) for crop growth, increased crop yields, improved quality of crops, and regulated growth cycle of crops.

Aim of this project is to design, develop and implement a sensor-based wireless communication system to monitor and control the agricultural parameters such as temperature and humidity in real time for better management and maintenance of agricultural production and to prevent the severe attack of diseases on the crops caused by the climatic conditions. In a monitoring system is proposed which integrates the system on chip (SoC) platform and ZigBee wireless network for precision agriculture. The designed system basically constitute sensors for field signal acquisition, MCU (Microcontroller with integrated LCD controller) as a front end processing device and Zigbee module to transmit the signal in wireless manner. The monitoring and control system

based on radio frequency (RF) transceiver for greenhouse is presented which consists of a few sensor nodes placed in greenhouse and a master node connected to host computer. The sensor nodes collect the signals from the greenhouse, transmits it through wireless RF transceiver and finally sends the data to the host computer for real time monitoring.

In this paper an electronic system based on a microcontroller that integrates ZIGBEE wireless functions with PC is designed and developed. The system allows the acquisition of different climatic parameters (temperature, humidity and soil moisture) in the agricultural greenhouse. In addition a graphical user interface using Labview software has been developed for the acquisition, monitoring through PC and storage of all data. At the same time this interface encompasses at the same time reliability, flexibility of use, interactivity and processing capability of the whole data in real-time. The first part of this paper is devoted to greenhouse structure set up, second part deals with wireless communication architecture, third part discusses on the experimentation and results and finally conclusions are drawn.

2. WIRELESS SYSTEM ARCHITECTURE AND ITS COMPONENTS

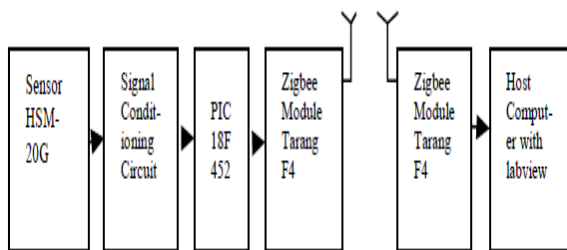

Fig – 1: Block diagram of wireless sensing system

This work is basically divided into the following modules: first is the HSM 20G humidity sensor module with the signal conditioning circuit, second is the PIC18F452 microcontroller, and third is the ZigBee transceiver present at both transmitting and receiving end. At the receiving end the ZigBee module is connected to the host computer for the purpose of continuous monitoring and database maintenance. The HSM 20 G is a precision integrated-circuit humidity and temperature sensor, whose output voltage is linearly proportional to temp in Celsius (Centigrade). The HSM 20G thus has an advantage over the linear temperature sensors calibrated in Kelvin, as the user is not required to subtract large constant voltage from its output to obtain convenient Centigrade scaling. It requires an input voltage of 5V. The HSM 20G is rated to operate over a 0°C to 50 °C temperature range.

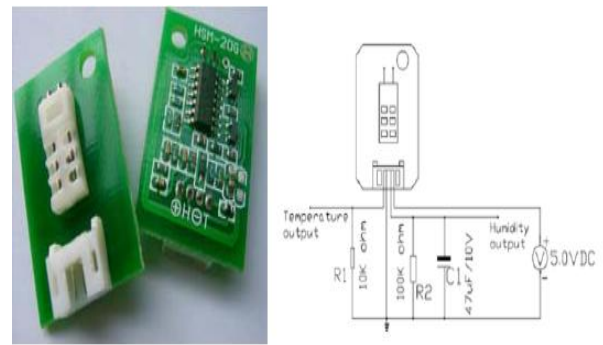

Fig – 2: HSM 20G

In this work PIC 18F452 microcontroller [9] is used to transfer the data to Zigbee module serially. Its pin configuration is shown in Fig. 3.

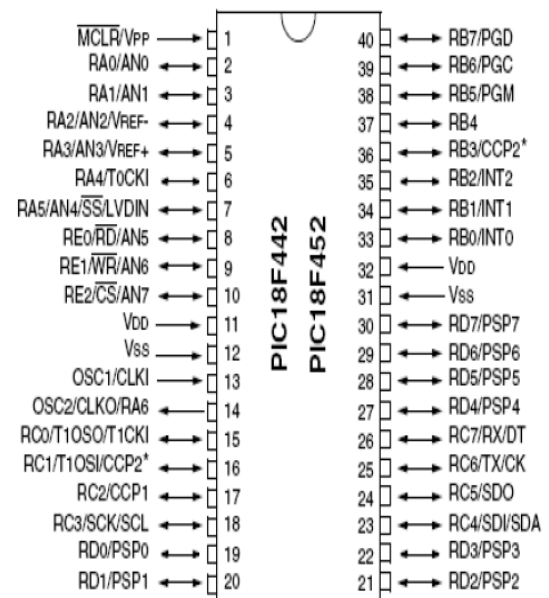

Fig – 3: Pin details of PIC 18F452

PIC 18F452 has Harvard architecture with a RISC processor inside. It is having a 40 pin DIP structure, 33 pins are set aside for five ports PORTA, PORTB, PORTC, PORTD and PORTE. Its standard features are on chip program (code) ROM, data RAM and data EEPROM, timers, ADC, USART etc. PIC18F452 has 10-bits in-built ADC, which converts the analog input data fed to it through PORTA pins. ADCs are mainly used for data acquisition. A strong feature of PIC I/O ports is that its individual bits can be accessed without altering the rest of the bits in that port. This can be used if we need to access few pins of the port instead of the entire 8 bits. PIC 18F452 reads the analog signals and deploys it on in built ADC which digitizes it to a 10 bit resolution data. A proper firmware is developed for dedicated applications, which computes signal into relative humidity in percentage and displays the same on the screen at the receiver end. TxD and RxD serial pins are used to interface the ZigBee module.

ZigBee is a short distance, simple-structured, low power, and low transmission rate wireless communication technology. It has a transmission range of 120 m and uses ISM 2.4GHz transmission frequencies. ZigBee is expected to provide low cost and low power connectivity for equipment that needs battery life as long as several months to several years but does not require data transfer rates as high as those enabled by Bluetooth. Tarang F4 developed by Melange Systems Pvt. Ltd. shown in Fig. 4 is used as a ZigBee transceiver module. Tarang F4 can be interfaced with the microcontroller or a PC using serial port with the help of appropriate level converter.



Fig -4: TARANG F4 module

Tarang F4 supports serial data with:

Flow Control : Hardware, none

Parity : None

Data Bits : 8

Baud Rates : 1200, 2400, 4800,9600,19200,
38400, 57600,115200

MPLAB is employed as the IDE and firmware is developed in embedded C environment. Tarang F4 is configured using the TMFT 2.6 software. It provides the terminal window which displays the received data. Labview is also used for displaying and acquiring the received data and to make control decisions. The ZigBee module in the field receives this control signals and transfers to the RxD pin of PIC microcontroller. The relays are connected to the microcontroller through signal conditioning circuits to actuate the switches of pumps and the exhaust fans.

3. EXPERIMENTATION AND RESULTS

Inside the Greenhouse the temperature and humidity are measured using HSM 20G IC sensor. For temperature measurement, the sensor is calibrated with standard RTD (PT100) along with its signal conditioning circuit shown in Fig. 6. The signal conditioning circuit consists of Wheatstone bridge and differential amplifier. Wheatstone bridge converts the resistance variation of the PT100 to millivolt variations for different temperatures. Differential amplifier amplifies this millivolt to voltage with a predetermined (10) gain.

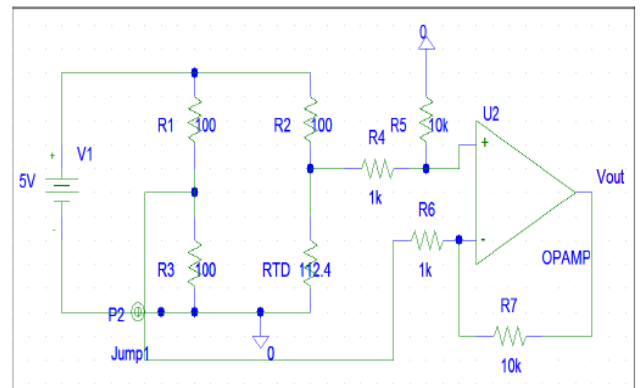

Fig -5: Signal conditioning circuit RTD

The HSM 20G is calibrated for 10% to 90% RH and 30°C to 70°C using the recommended signal conditioning circuit shown in Fig. 3. These sensors output voltages are fed to the ADC (pin no 3, 4, 5, 7, 8) of the PIC18F452. The inbuilt 10 bit ADC converts the analog signals from the sensors to digital. These digital signals are converted into the corresponding temperatures and humidity during the execution of the firmware. The temperatures and humidity are calculated by using the equations obtained from the calibration of the corresponding sensors. The observed voltage against temperature in °C and the humidity in % RH from HSM 20G sensors are shown in Fig.7 and Fig.8 respectively.

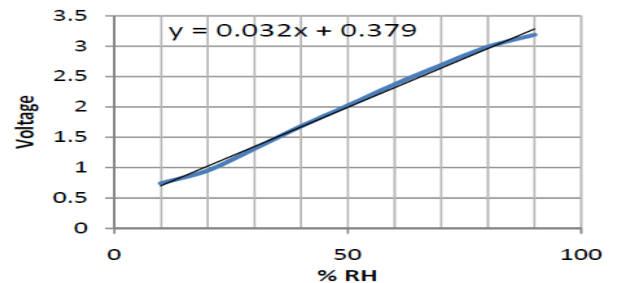

Chart -1: Humidity Vs Output voltage (HSM 20G)

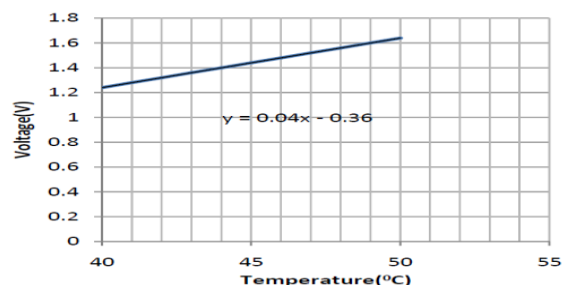

Chart -1: Temperature Vs Output voltage (HSM 20G)

An embedded system is developed to measure humidity and temperature. The sensor data is transmitted to analog input pins of the microcontroller. After processing the data, it is transmitted through ZigBee, which is connected to serial output pin of the microcontroller. At the receiver end, the

zigbee module in the control room is connected to the host computer through RS-232. The LABVIEW software is used to present the data at the user end. This data is then stored as a text file for database maintenance. The LABVIEW program is in such a way that it can be worked in two different modes, read mode and write mode. In read mode it will read the received data and shows it in the front panel and in the write mode the generated control signals are sent from the LABVIEW. These control signals are transmitted to the zigbee module in the field from the control room zigbee module. The 'data out' pin of the field zigbee module is connected to the RX pin (pin no 26) of the PIC microcontroller. These control signals changes the status of the relays in the field. The host computer displays the current value of the temperature, humidity and also the status of the relays in the greenhouse. Relays are controlled by the control signals from the host computer based on the set points specified by the user. The relays are connected to the microcontroller to carry out the required control function. The firmware consists of the serial reception instruction which helps to control the status of the relays. The two relays are connected to the 'interrupt' pins (pin no 33, 34) of the microcontroller. The firmware controls the status of the relays according to the control signals send by the user from the control room. The implemented hardware set up is shown in Fig. 10. The front panel and the block diagram developed in LABVIEW for real time monitoring and control is shown in Fig. 10 and Fig. 11 respectively. This real time monitoring provides reliable, timely information of crop and soil status which is important in taking decisions for crop production improvement.

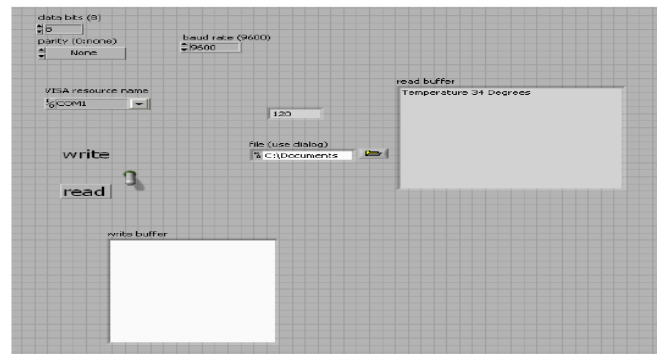

Fig -7: LABVIEW front panel

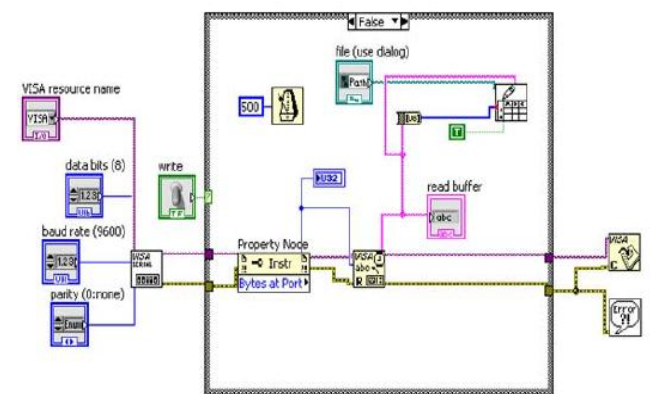

Fig -8: LABVIEW block diagram

4. CONCLUSION

In green house technology, the automation of agricultural parameters becomes a necessary part. Hence wireless communication with simple hardware and user friendly software like Labview is shown to be an efficient solution for automated green house. In this paper a precision Green house management approach to monitor and control the climate and irrigation system is demonstrated. It is proved to be a boon for Hi Tech agricultural field. Although the experimental results have shown for two parameters, the system is completely scalable. The proposed approach has a great potential for remote crop monitoring and control using WSN technology for large scale green house. The system presented here is user friendly, low cost and can be easily implemented.

REFERENCES

[1] Deng Xiao lei, Zheng Lihua, Li Minzan, "Development of a Field Wireless Sensors Network Based on ZigBee Technology," World Automation Congress (WAC), 2010, pp 463 - 467.
 [2] Yunseop (James) Kim, Robert G. Evans, and William M. Iversen, "Remote Sensing and Control of an Irrigation System Using a Distributed Wireless Sensor Network, "IEEE

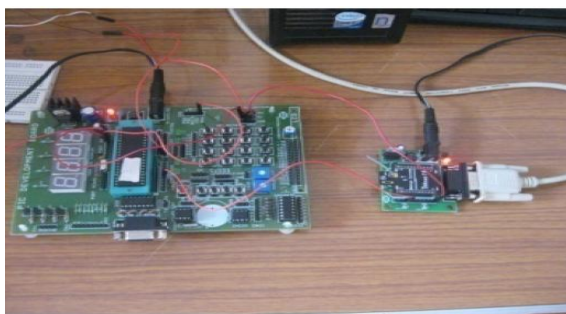

(a)

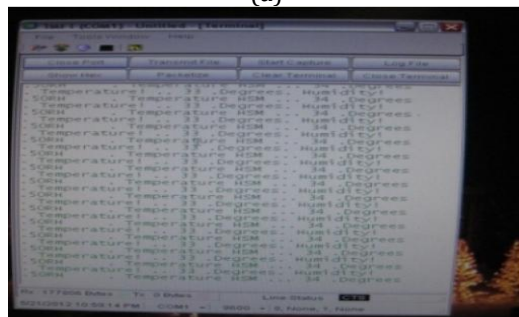

(b)

Fig -6: (a) Transceiver module with microcontroller board
 (b) Monitoring of data in computer screen

Transactions on Instrumentation and Measurement, vol. 57, No. 7, July 2008.

[3] Xuemei Li, Yuyan Deng, Lixing Ding, "Study on Precision Agriculture Monitoring Framework Based on WSN," 2nd International Conference on Anti-counterfeiting, Security and Identification, 2008. ASID 2008. pp 182 – 185.

[4] Chandani Anand, Shashikant Sadistap, Satish Bindal and K. S. N. Rao, "Multi -Sensor Embedded System for Agro-Industrial Applications," 2009 Third International Conference on Sensor Technologies and Applications.

[5] Ning Wang , Naiqian Zhang , Maohua Wang "Wireless sensors in agriculture and food industry—Recent development and future perspective,"Computers and Electronics in Agriculture 50 (2006) 1–

[6] Muhammad Ali Mazidi,Rolin D.Mckinlay, Danny Causey, "PIC Microcontroller And Embedded Systems Using Assembly and C for PIC18," Edition 2008,Pearson Education

[7] Dogan Ibrahim, "Advanced PIC Microcontroller Projects in C-From USB to Zigbee with the PIC18F series,"Edition 2008, Elsevier Ltd.

[8] Martin P.Bates, "Programming 8-Bit PIC Microcontrollers in C with interactive hardware simulation," Edition 2008, Elsevier Ltd. Datasheet

BIOGRAPHIES



G.GNANAVEL,
V.R.S College of Engineering and
Technology,
ASSISTANT PROFESSOR



E.EZHILARASAN,
V.R.S College of Engineering and
Technology,
ASSISTANT PROFESSOR



N.PAVITHRA,
V.R.S College of Engineering and
Technology,
PG SCHOLAR