

# Performance Evolution of Domestic Refrigerator Using LPG Cylinder

Mhaske M. S.<sup>1</sup>, Deshmukh T. S.<sup>2</sup>, Ankush D. D.<sup>3</sup>, Palkar S. M.<sup>4</sup>, Gaikwad V. S.<sup>5</sup>

<sup>1</sup>Asst. Professor, Dept. of Mechanical Engineering, PREC, Loni, Maharashtra, India

<sup>2,3,4,5</sup>Student, Dept. of Mechanical Engineering, PREC, Loni, Maharashtra, India

\*\*\*

**Abstract** - In this project we have designed and analyzed a refrigerator using LPG as refrigerant. As the pressure of LPG is high this stored in cylinder. As this pressurised LPG is passed through the capillary tube of small internal diameter, the pressure of LPG is decreased due to expansion and phase change of LPG occurs in an isenthalpic process. Due to phase change from liquid to gas latent heat of evaporation is gained by the liquid refrigerant and the temperature decreased. In this way LPG can produce refrigerating effect in the surrounding. From experimental investigations, we have found that the COP of a LPG Refrigerator is higher than a domestic refrigerator.

**Key Words:** LPG Refrigeration, Capillary tube, Evaporator, COP, Vapour Compression Refrigeration system, Refrigerating Effect.

## 1. INTRODUCTION

Due to the huge demand of electricity over the world, we think of recovering the energy which is already spent but not being utilized further, to overcome this crisis with less investment. The climatic change and global warming demand accessible and affordable cooling systems in the form of refrigerators and air conditioners. Annually Billions of dollars are spent in serving this purpose. Hence forth, we suggest COST FREE Cooling Systems. LPG is stored in liquefied state in cylinder before its utilization as fuel. According to the energy survey, the refrigerator is one of the heaviest power consumers amongst household appliances. The energy consumption of refrigerators has improved steadily year over year. It works on the principle that the expansion of LPG will be takes place during the conversion of liquid LPG into gaseous form. As a result of this, LPG gas pressure drops and the volume of gas will be increase this will be result into dropped in temperature of gas and it acts as refrigerant. According to second law of thermodynamics, this process of cooling can only be performed with the aid of some external work. Hence, the power supply is regularly required to drive a refrigerator. The substance which works in a refrigerator to extract heat from a cold body and to deliver it to a hot body i.e.to surrounding is called refrigerant. Globally 17500 metric tons of conventional refrigerants is consumed by domestic refrigeration like CFC, HFC which causes high depletion if ozone layer (ODP) and Global Warming Potential (GWP). The use of LPG instead of

CFC 22 has made a better progress since it has an environment friendly orientation with no ODP. Good product efficiency is resulted by the use of LPG because of its characteristics. Thus we have to examine these two types of refrigerants (LPG and CFC 22) in a modified domestic refrigerator comparing their performance characteristics parameters like pressure, temperature etc. in refrigerator and considering safety while conducting the practical experiment. It indicates LPG can be used as an alternative refrigerant to CFC 22 after performing the test on new system.

## 1.1 Objectives

The Objectives of this project "Performance evolution of Domestic Refrigerator using LPG Cylinder" are as follows:

- 1) To identify the form of residual waste in traditional refrigeration system.
- 2) Compare the important characteristics between LPG refrigeration system and traditional refrigeration system.
- 3) To distinguish between the current existing refrigerator cost and estimated cost of LPG refrigerator.
- 4) The performance of existing refrigerator and LPG refrigerator is to be compared.

## 1.2 Scope of Work

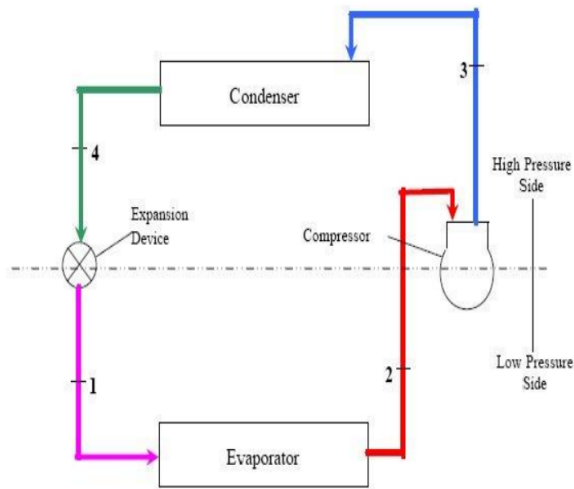
To study and analyze the Vapour Compression Refrigeration system is our basic objective. We are substituting the compressor and condenser by a LPG cylinder. The pressure energy of LPG is very high as it can be compressed up to 12.5 bars and hence this pressure energy of LPG can be used for refrigeration by usage of this LPG system is also very low.

## 2. EXPERIMENTAL SETUP

### 2.1 Working Principle

The LPG Refrigerator is work on the simple Vapour Compression Refrigeration system. The construction and working of simple VCRCs is as shown in fig. 1

Process 2-3: When the compressor is started, it draws the low pressure vapour from the evaporator at state 2 and compresses it is entropically to a sufficiently to a high pressure up to state 3. Since the compression work is done on the vapour, its temp also increases.



**Fig-1:** Schematic diagram of simple VCRs

Process 3-4: Hot vapour from compressor under pressure is discharged into the condenser where condenser cooling medium usually water or surrounding air is absorb the heat from hot vapour. This converts the hot vapour into liquid and the liquid is collected in liquid receiver at state 4.

Process 4-1: The liquid from the liquid receiver at high pressure is then piped to a refrigerant control valve which regulates the flow of liquid into the evaporator. This control valve, while restricting the flow, also reduces the pressure of the liquid with the result the liquid change into vapour of low dryness fraction represented by state 1. During this process the temperature of the refrigerant reduces corresponding to its pressure.

Process 1-2: Finally, the low pressure, low temperature refrigerant passes through the evaporator coil where it absorb its latent heat from the cold chamber or from brine solution at constant pressure and converts into vapour at state 2. It is again supplied to compressor. Thus, the cycle is completed.

## 2.2 Actual System Setup

The simple mechanism of the LPG refrigeration working is shown in figure 2.

The idea behind LPG refrigeration is to absorb heat from surrounding by using the evaporation of a LPG. The pressure of LPG which is stored in cylinder is at about 80 psi. We lowering this pressure of LPG up to pressure 15 psi by using capillary and so that cooling is done on surrounding by absorbing heat isentropically. Pressure of LPG in cylinder is high, when the regulator of gas tank is opened then high pressure LPG passes through gas pipe. After that this high pressure LPG is goes in the capillary tube from high pressure pipe. In the capillary tube this high pressure LPG is

converted in to low pressure adiabatically i.e. enthalpy remains constant. After capillary tube, this low pressure LPG is passed through evaporator. In the evaporator LPG is converted into low pressure and temperature vapour form which absorbs the heat from the cooling chamber. Thus the cooling chamber becomes cools down.



**Fig.-2:** Actual Setup of LPG Refrigerator



**Fig.-3:** Actual Setup of LPG Refrigerator

Thus we can get refrigerating effect in refrigerator. After that the low pressure LPG from evaporator is passed to the burner through high pressure pipe and we can use this low pressure LPG for burning for further application. In this project we use recompressed LPG cylinder instead of compressor. In this way we can achieve refrigerating effect from this system.

## 2.2.1 Construction Features

### A. LPG Gas Cylinder

LPG is general composition of two gases mainly Propane (C<sub>3</sub>H<sub>8</sub>) and Butane (C<sub>4</sub>H<sub>10</sub>), either stored separately or together as a mixture in a cylinder. These gases can be liquefied at a normal temperature by application of a pressure increases. LPG is stored in a cylinder at about 12.5 bars.



**Fig-4:** LPG Gas Cylinder

LPG is used as a fuel for industrial, horticultural, cooking, agricultural, heating and drying processes. LPG can be used as a fuel for automobiles.

### B. Capillary Tube

The capillary tube is the commonly used throttling device in the domestic refrigeration. As you know, the fluid pressure drops when it flows through a conduit. Same principle is used in the capillary tube.



**Fig-5:** Copper Capillary Tube

A capillary tube is of copper having a small bore diameter. It reduces the pressure of liquid refrigerant from condenser pressure to evaporator pressure when connected to a liquid line. The length of capillary tube is greater when the evaporator pressure is lower. The capillary tube is a simple device with no moving part. However its small bore makes it necessary that a filter and drier is fitted before the capillary tube to prevent choking.

### C. Evaporator

The evaporator is also an important component of the refrigeration system. The cooling effect is produced by passing the refrigerant through evaporator coil.



**Fig-6:** Evaporator

The actual cooling effect takes place inside the evaporator in the refrigeration systems. The heat is removed from the substance by transferring the heat from the substance to be cooled to the refrigerant with the help of evaporator. Thus the evaporator acts as heat exchanger surface. The application of evaporator in refrigeration system is variant, thus evaporator is available in various design, dimensions and shapes. Depending on the method of input of refrigerant they are also classified in different ways, the air circulation direction around the evaporator. The freezers are the evaporators as the water freezes into ice in this compartment. The refrigerant is passed through the capillary tube at very low temperature and pressure to the evaporators. The heat is absorbed by this refrigerant from the substance that is to be cooled and thus the refrigerant gets heated while the substance is cooled. In spite of cooling the substance the refrigerant temperature leaving the evaporator is lower than that of the substance. In large refrigeration system the application of evaporators is mainly for chilling water, thus shell and tube type heat exchangers are used as evaporator.

### D. Pressure Gauge

There are many techniques for the measurement of pressure and vacuums. Pressure gauges and vacuum gauges are the instruments used to measure pressure.



**Fig-7:** Pressure Gauge

The most commonly used mechanical gauge is Bourdon type pressure gauge. It is a stiff, flattened metal tube bent into a circular shape. The fluid whose pressure is to be measured is inside the tube. One end of the tube is fixed and other end is free to move inward or outward. The inward and outward movement of free end moves a pointer, through a linkage and gear arrangement, a dial graduated in pressure unit i.e. bar. Pressure gauge records the gauge pressure which is the difference between fluid pressure and outside atmospheric pressure. These gauges are available in the different ranges of pressure.

**E. High Pressure Pipes**



**Fig-8:** High Pressure Pipe

When there is a need of transferring gas at high pressure, the range of high pressure pipes are used. It consists of a steel pipe with steel spheres fixed at both the terminals. These spheres are pressed against the seating of connecting hole with the help of two swiveling nipple and thus the gas leakage is prevented.

**3. EXPERIMENTAL ANALYSIS**

**3.1 Specifications of Components.**

**1. Copper Tubes:** According to the pressure 100 psi the outside diameter of tube = 7 mm and the thickness of the tube is = 1.5 mm.

**2. Capillary tube:** By considering the pressure and flow rate we select the capillary tube with internal diameter 0.78mm and length 2.95m.

**3. Evaporator:** We select the evaporator of standard size of domestic refrigerator which is plate and tube type evaporator.

The evaporator has following dimensions:  
Length = 325 mm, Breadth = 265 mm and  
Height = 135 mm

The evaporator is made from six plywood sheets of 8 mm thickness which enclose six glass wool sheets of 12 mm thickness so as to prevent heat transfer.

The experiment of this project was done on March 13, 2016 at 2 p.m. and readings were taken under fifteen minute's intervals which are under as follow:

**3.2 Operational Parameters**

1. Size of Refrigerator: 325 X 265 X 135

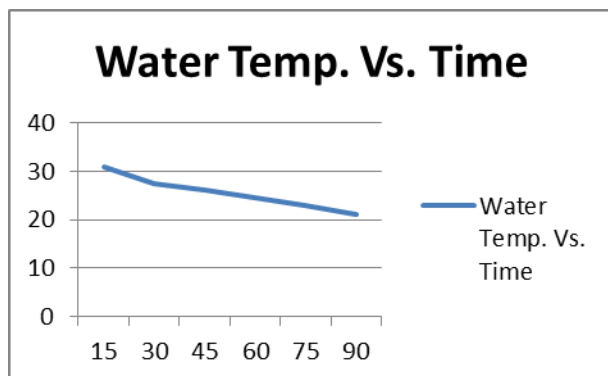
2. Initial temperature of water at the time of experiment: 31°C

3. Initial temperature of evaporator at the time of experiment: 29.5°C

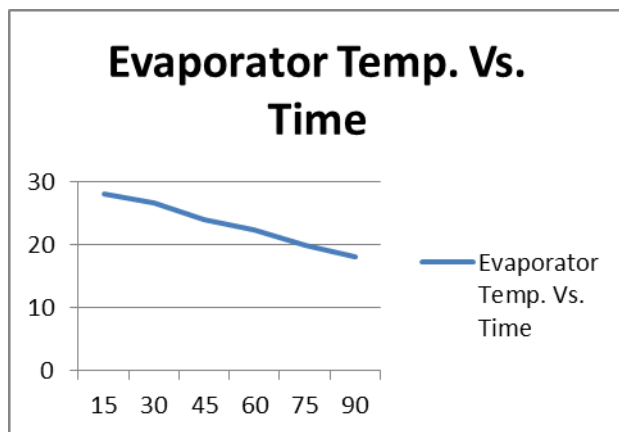
**Table-1:** Observation Table

Time (min)	Inlet Pressure (bar)	Outlet Pressure (bar)	Water temp. (°C)	Evapo. Temp. (°C)
15	5.525	1.22	30.9	28
30	5.525	1.22	27.4	26.6
40	5.525	1.22	26	24
60	5.525	1.22	24.4	22.4
75	5.525	1.22	22.8	20
90	5.525	1.22	21	18

**Charts**

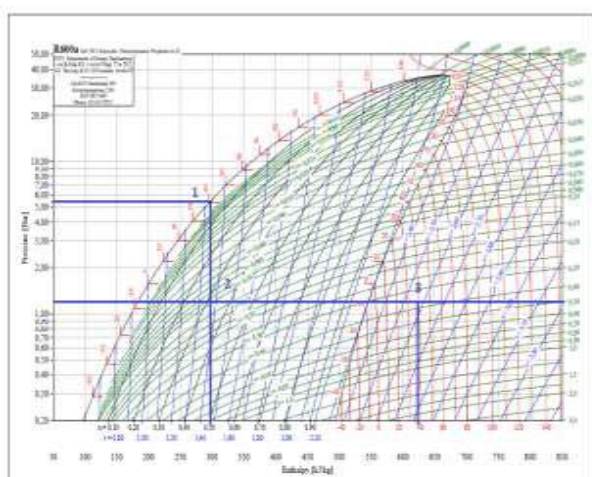


**Chart-1:** Water Temp. Vs. Time



**Chart-2:** Evaporator Temp. Vs. Time

The p-h diagram for LPG refrigeration system is as follows.



**Fig-9:** p-h diagram of LPG Refrigeration system

**3.3 Refrigerating Effect**

The properties of LPG at 5.525 bars are  
 Enthalpy  $h_1 = 430.3 \text{ kJ/Kg}$   
 The properties of LPG at 1.22 bars are

Enthalpy  $h_f = 107.3 \text{ kJ/Kg}$

Temp.  $t_{\text{sat}} = -30 \text{ }^\circ\text{C}$

Heat extracted from evaporator in 1.5 hour ( $Q_{\text{eva}}$ ) = Heat absorbed by LPG ( $Q_{\text{LPG}}$ )

( $Q_{\text{eva}}$ ) = Heat absorbed from (water + surrounding air inside of evaporator + leakage)

$m_w =$  mass of water = 1kg

$c_{pw} =$  specific heat of water = 4180J/kg.K

$(\Delta T)_w = 10^\circ\text{C}$

$X_{\text{LPG}} =$  Dryness fraction of LPG from graph = 0.5

$(Q_{\text{eva}}) = Q_{\text{eva}} + Q_{\text{air}} + Q_L$

$= m_w c_{pw} (\Delta T) + m_a c_{pa} (\Delta T) + Q_L$

We have taken 1 kg of water in bottle.

Since there is very less amount of air so it is neglected.

$$= 1 \times 4180 \times 10$$

$$= 41800 \text{ J}$$

Heat absorbed by LPG ( $Q_{\text{LPG}}$ ) = Latent heat absorbed

( $Q_L$ )<sub>LPG</sub> + Sensible heat gain ( $Q_{\text{Sen}}$ )<sub>LPG</sub>

We have the volume flow rate of LPG is 0.1 liter per min. and the specific volume of LPG at 1.22 bar pressure is  $1.763 \times 10^{-3} \text{ m}^3/\text{Kg}$ .

Therefore mass flow rate of LPG is =  $0.0001 / 1.763 \times 10^{-3}$

$$= 0.0567 \text{ Kg/min}$$

$$m = 9.448 \times 10^{-4} \text{ Kg/sec}$$

$$= m_{\text{LPG}} \cdot X_{\text{LPG}} \cdot h_{fg} + m_{\text{LPG}} \cdot c_{p\text{LPG}} \cdot (T_{\text{sup}} - T_{\text{sat}})$$

$$= 9.448 \times 10^{-4} \times 0.5 \times 375 \times 103 \times 5400 +$$

$$9.448 \times 10^{-4} \times 1.67 \times (48)$$

$$= 0.956812 \text{ MJ/Hr.}$$

$$h_2 = h_f + X \cdot h_{fg}$$

$$= 107.3 + 0.5 \times 375$$

$$= 294.8 \text{ KJ/Kg}$$

$$h_g = h_f + h_{fg}$$

$$= 107.3 + 375$$

$$= 482.3 \text{ KJ/Kg.}$$

$$h_3 = h_g + C_p \cdot \Delta T$$

$$= 482.3 + 1.67 \times 48$$

$$= 562.46 \text{ KJ/Kg}$$

So the refrigerating effect is,

$$RE = h_3 - h_2$$

$$= 562.46 - 294.8$$

$$= 267.66 \text{ KJ/Kg}$$

For calculating the COP of the system, we required the work input. For work input we have a 14.5 Kg. LPG cylinder. Hence, input work is the amount of power required for filling 1 cylinder. From the PCRA energy audit report power required to refill 1 cylinder is 3.1354kWh.

Therefore, for filling 1 kg of LPG power required is,

$$= 3.1354 / 14.5$$

$$= 0.2162 \text{ kWh}$$

We run the setup for 1.5 hr. for that power is

$$= 0.2162 \times 1000 / (9.45 / 10000) \times 5400$$

$$= 42.39 \text{ W}$$

### 3.4 COP of the LPG Refrigeration System

$$\text{COP} = (h_3 - h_2) / W$$

$$= 267.66 / 42.39$$

$$= 6.3$$

After finding out the COP of the LPG refrigerator we found out the heat liberated by LPG after burning in the burner with the burner efficiency of 92 %.

Heat liberated by LPG to atm.  $Q_L = m \times C_v$

The volume flow rate of LPG is 0.1 liter per min. and the specific volume of LPG at 1.525 bar pressure is

$$1.763 \times 10^{-3} \text{ m}^3/\text{Kg}$$

Therefore mass flow rate of LPG is

$$= 0.0001 / 1.763 \times 10^{-3}$$

$$= 0.0567 \text{ Kg}/\text{min}$$

$$m = 9.448 \times 10^{-4} \text{ Kg}/\text{sec}$$

$$C_v = 46.1 \text{ MJ}/\text{Kg}$$

$$Q_L = 9.448 \times 10^{-4} \times 46.1 \times 10^3$$

$$= 43.56 \text{ W}$$

Hence, from this we have got the refrigerating effect from the system as well as heat from the LPG.

## 4. COMPARE WITH DOMESTIC REFRIGERATOR

Cop of a domestic refrigerator is normally up to 2.95 which is lesser than the LPG refrigerator. Domestic refrigerator required high input power than LPG refrigerator. Also there are more moving parts in domestic refrigerator and not eco-friendly. Domestic refrigerator requires more maintenance and operation is noisy.

## 5. FUTURE SCOPE

An introduction of new product in the field of refrigeration is expected and to give out positive result with this normal product. The main aim is to focus on restaurant and community program hall, mid-day meal of school so to preserve food products like vegetables, milk etc. Also at small snack stores by increasing the probability of refrigerator by reducing its weight, removing compressor totally as well as maximum cost reduction due to no cost of refrigeration.

(1) The mine, desert and research areas and countries where lack of electricity this product might be beneficial.

(2) This product can also hold good application in an LPG car air conditioning.

## 6. CONCLUSIONS

The basic goal of the LPG refrigerator was to use the LPG as refrigerant and usage of this high pressure energy in the LPG cylinder for refrigerating effect. The LPG pressure is

as high as 12.41 bars in a domestic 14.5 kg cylinder which we have regulated with the use of capillary tube and brought down up to 1.41 bars. But practically the usage of a low pressure regulator in a traditional domestic LPG gas stove might lead to a difference in the pressure of LPG after passing over the expansion device and before reaching the gas burner. So to avoid this, the refrigerating effect was calculated by us by varying the LPG properties like (pressure, temperature and enthalpy) to and fro the evaporator using a high pressure regulator and the quantity of refrigerating effect we get is 267.66 KJ/kg. We cannot predict the quantity of energy that might be used up in filling of 1 kg LPG in the refinery and no data available in any energy audit report of refinery, so we have considered the input energy from the refilling plant only.

We get slow rate of refrigerating effect because of leakages present in the system. This can be improved by using precise manufacturing techniques and methods.

For input energy we have taken the amount of energy required to refill 1 kg of LPG through the bottle filling plant which is 0.216 kWh. The input energy for different plant might be different. If we give an energy input in this way we get the COP of the LPG refrigerator 6.3 and which is again higher than the domestic refrigerator. There also might be a change in future scope if the energy input for 1kg of LPG filling would be taken from any of the refinery energy audit report.

In a LPG refrigeration system capillary tube is more adjustable and better device. The initial and running cost of this LPG refrigeration system is really less. No outside energy source is required to run the system. As well as no moving components are present in the system which further reduces the maintenance cost as well. This LPG refrigeration system has wide scale application in hotel industries, chemical industries where the LPG consumption is at a higher level.

## REFERENCES

- [1] Zainal Zakaria and Zulaikha Shahrin "The possibility of using liquefied petroleum gas in domestic refrigeration system" International Journal of Research and Reviews in Applied Science(IJRRAS), December 2011, Volume9
- [2] Vishwadipsingh J. Ghariya and Swastik R. Gajjar "International Journal for Scientific Research and Development" ISSN (online): 2321-0613, March 2014, Vol.2
- [3] Ibrahim Hussain Shah and Kundan Gupta "International Journal of Engineering Sciences and Research Technology" ISSN: 2277-9655, July 2014, Vol. 3(206-213).
- [4] Khandare R. S. and Bhane A. B "International Journal of Emerging Technology and Advanced Engineering" ISSN: 2250-2459, March 2015, Volume 5.
- [5] A Textbook of Refrigeration And Air Conditioning By R.S. Khurmi, S. Chand Publication.

- [6] "PCRA energy audit report", HPCL LPG bottling plant Asauda Bahadurgarh (Haryana) Dec. 2006.
- [7] "Basic statics on Indian petroleum and natural gas" 2006-07.
- [8] Shank K. Wang, "Handbook of air conditioning and refrigeration" page no. 11.14 chapter 11.
- [9] S. J. Cleg, "Thermodynamic analysis of LPG as refrigerant for industrial refrigeration and transportation", Institute of Transport Studies, University of Leeds, Working paper of 471, 1996.
- [10] Dr. IqbalHusain, "Analysis of VCR and VAR systems using organic refrigerants", CRC press, Taylor and Francis Group, USA, 2012.
- [11] Text book of refrigeration and air conditioning by Arora and Domkundwar.
- [12] Catalogue of Gas Authority of India on "Properties of combustible gases for industrial purpose".