

SYNTHESIS AND CHARACTERIZATION OF NANO ALUMINIUM PARTICLES

Dr. Siny Paul¹, Vishnu K², Rahul Uday³, Sandeep Athiyarath⁴

¹Associate Professor, Dept. of Electrical and Electronics, Mar Athanasius College of Engineering, Kothamangalam

²Student, Dept. of Electrical and Electronics, Mar Athanasius College of Engineering, Kothamangalam

³Student, Dept. of Electrical and Electronics, Mar Athanasius College of Engineering, Kothamangalam

⁴Student, Dept. of Electrical and Electronics, Mar Athanasius College of Engineering, Kothamangalam

Abstract - Nanotechnology refers to the science and technology conducted at the nanometric scale, precisely 1 to 100 nm. Nano science and Nanotechnology are the study and application of materials of extremely small size and is used across growing fields of scientific research and commercial development. Nano size particles have very large specific surface area resulting in special physical and chemical properties. The main objective of the present research is the production of high purity Nano aluminium powder using pulse power technique. The main advantage of this method is that the size of particles could be carried by varying the injected power and other appreciable features of this technique are the high energy efficiency and high product purity. In the present study charging voltage, dielectric strength of operating medium, length and size of operating wire on the production of Nano particle were analyzed. The production of nano sized powder is one of the main application of wire explosion method, and it is a simple method for producing various kinds of nano sized powders with particle diameters around 1 to 100 nm. In the present work, wire explosion technique is adopted, which is a top down approach for producing nano powders. It is an evaporation technique, where the particles are produced when a high pulsed current is allowed to pass through a thin metallic conductor. This deposited energy melts evaporates and ionizes the wire material resulting in the production of high temperature plasma that expands into the liquid medium and then cools gradually due to the interaction with liquid resulting in a vapor of the wire material that gets uniformly condensed in liquid media to form nanoparticles.

Key Words: Nano particles, Electric explosion process, Trigratron Switch, Centrifugation, SEM, TEM, XRD.

1. INTRODUCTION

Nanotechnology refers to the science and technology conducted at the nanometric scale, precisely 1 to 100 nm. Nano science and Nanotechnology are the study and application of materials of extremely small size and is used across growing fields of scientific research and commercial development. Nano size particles have very large specific surface area resulting in special physical and chemical

properties. For this reason, nano size powders are of several interesting application in material processing for electronics, optics and magnetics. They are also applicable as pigments, catalysts and even used as propellants. They also find applications in physics, biology, chemistry and engineering.

Here wire explosion technique is adopted, which is a top down approach to produce nano powders. The production of nano sized powder is one of the main application of wire explosion method, and it is a simple method for producing various kinds of nano sized powders with particle diameters between 1 to 100 nm. It is an evaporation technique, where the particles are produced when a high pulsed current is allowed to pass through a thin metallic conductor. This deposited energy melts, evaporates and ionizes the wire material resulting in the production of high temperature plasma that expands into the liquid medium and then cools gradually due to the interaction with liquid resulting in a vapour of the wire material that gets uniformly condensed in liquid media to form nanoparticles [1].

The main objective of the present task is the production of high purity aluminium nano particles using pulse power method and thereby corroborating the formation of nano particles by characterisation. The main advantage of this method is that the size of particles could be varied by varying the injected power and other appreciable features of this technique are the high energy efficiency and high product purity. Compared to conventional wire explosion in wire there are several advantages in wire explosion method carried out in liquid media. One such advantage is that a non-oxide metal powder can be produced without a vacuum process, and this phase can be kept safely to the final stage of applications. In the present study dielectric strength of operating medium, charging voltage and length and size of operating wire were analyzed.

2. WIRE EXPLOSION METHOD

Exploding Wire Method (also known as EWM) is a process in which a rising current is applied to a thin electrically conductive wire for a short duration. The high current heats and melts the wire and causes the wire explosion. Exploding Wire Method is best known to be used as a detonator in

nuclear munitions, high intensity light source, and production method for metal nanoparticles [2].

The main components needed for the exploding wire method are a thin wire of small diameter, a capacitor, a high voltage source and a chamber for the explosion. The wire is typically silver, gold, aluminum, copper, iron or platinum, and is usually less than 0.5mm in diameter. The energy consumption of capacitor is about 25kWh/kg and discharges a pulse of charge density $10^4 - 10^6$ A/mm², leading to temperatures up to 100,000K. This occurs over a very short time period of only 10^{-5} - 10^{-8} seconds [2].

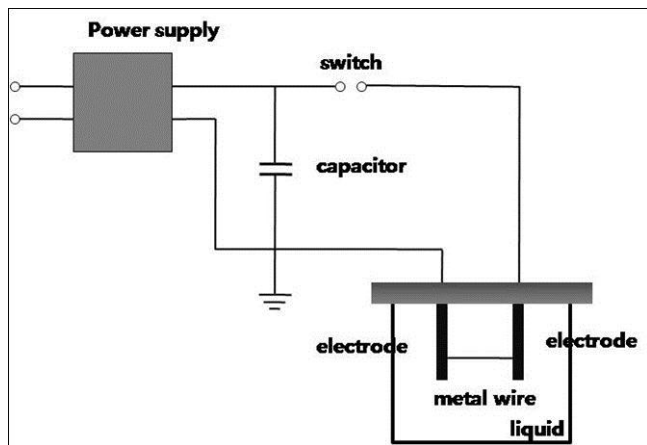

Fig-1: Wire explosion method- Basic circuit

Wire explosion method in liquid media is a method employed for nano material production without the creation of oxide forms. EWM is a top down approach that melts, evaporates, ionizes the wire resulting in the production of plasma that expands in the liquid medium, later it condenses in the liquid to form nanoparticles. The process of sedimentation and separation can be accelerated by the use of a centrifugal separator.

The process is as follows:

1. A high voltage supplied by means of a transformer is applied to the setup consisting of capacitors, resistors and trigatron gap and trigatron switch
2. The capacitor charges up to a rising current and this is used to melt the wire. The metal melts to form a broken series of imperfect spheres called unduloids. The current rises in such a way that the liquid metal has no time to move out of the way.
3. The unduloids vaporize. The metal vapour creates a lower resistance path, allowing a faster current increase.
4. An electric arc is formed, which turns the vapour into plasma. A bright ash of light is also produced.

5. The plasma is allowed to expand freely, creating a shock wave.

6. Electromagnetic radiation is released in tandem with the shock wave.

7. The shock wave pushes liquid, gaseous and plasmatic metal outwards, breaking the circuit and ending the process.

2.1 Chamber Design

The experiment is carried out in a chamber made of PVC material having 200 mm diameter and 150 mm height. It has two electrodes fixed on an insulating wood and separated by a distance of 25 mm. A wire of diameter 0.04 mm is tied across the two electrodes. Once the wire is attached, the chamber is closed with the top cover such that the wire is dipped in distilled water. After each explosion, a new wire is tied between the electrodes. When an appreciable amount of energy is passed through the wire it turns into a plasma state.



Fig-2: Chamber Design

2.2 Calculation of energy to be deposited

For an aluminium wire of 25 mm length and diameter of 0.04 mm,

Total energy required for evaporation = Energy required to melt the wire + Latent heat of fusion + Latent heat of vaporization + Energy required to evaporate the wire.

Specific heat capacity of Aluminium (cs) = 904 J/Kg / degree Celsius at 25 degree Celsius.

Melting point of Aluminium (mp) = 933.5 k

Boiling point of Aluminium (bp) = 2792 k

Latent heat of fusion (lf) =398000 J/Kg

Latent heat of vaporization (le) =10530000 J/Kg

Aluminium density = 2700 Kg/m³

Mass (m) = density * volume

Volume =1.256*10⁻¹⁰ m³

Mass = 3.3912*10⁻⁶ Kg

Energy stored in capacitor =0.5CV²

Available capacitor is of 50000 pf.

0.5CV²= mcs (tm-tr) + mlf + mcs (tb-tm) + mle = 4.476 J

So V = 13.381 kV.

For converting the wire into plasma state about 6 times the evaporation energy is passed. The amount of energy varies with the properties of the material used, the medium used and the atmospheric conditions. In this case the voltage was in about 60kV to 70kV range. This was done by trial and error method.

2.3 Impulse setup for high voltage generation

Impulse generator is an electrical apparatus that can produce high current or high voltage surges of very short duration.It can be categorised into two types: impulse current generator and impulse voltage generator. High impulse currents are needed for tests on equipment such as fuses and lightning arresters as well as for several other technical applications such as lasers, thermonuclear fusion, and plasma devices. High impulse voltages are used for testing the strength of electric power equipment against switching and lightning surges.

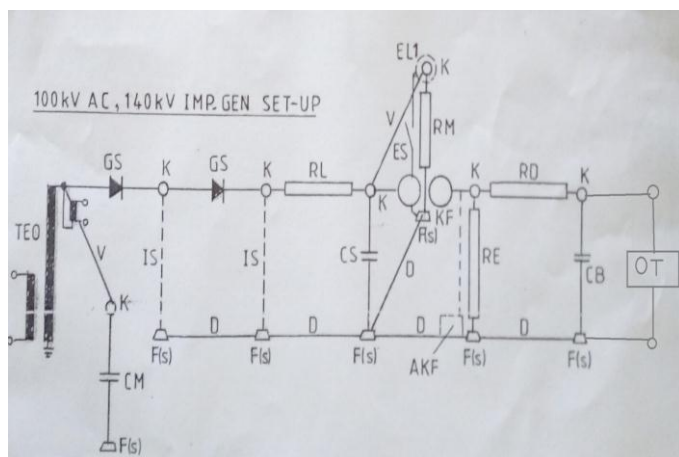

Fig-3: Connection Diagram

An example of impulse generator is the Marx generator. It has multiple capacitors that are initially charged in parallel through charging resistors from a high voltage DC source. When sparking appears at the sphere gap, all the capacitors gets connected in series and the discharge occurs through a test object.

The ac supply is given to the primary of the transformer. The input voltage can be varied for changing the output voltage. The output is given to the rectifier and its output is used to charge the capacitor. When the capacitor voltage exceeds the sphere gap voltage or the break down voltage the high voltage in the range of kV reaches the wire connected between the wires and causing evaporation of the wire.

3. EXPERIMENTAL SETUP

The experimental setup for the electric wire explosion process for liquid media is shown in figure. The experiment is carried out in a cylindrical chamber of 200 mm diameter and 150 mm height made up of PVC material. The cylinder is partially filled with distilled water .The electrodes are fixed on an insulated wooden structure with a gap distance of 25 mm. The wire of diameter 0.04 mm diameter is connected across the fixed electrodes and can be rewired after every explosion. The top wooden support is used for additional support. Once the wire is connected the chamber is closed with the wooden structure such that the wire is dipped in distilled water [1].



Fig- 4: Experimental Setup

A capacitor of 50000 pF charged to 60 kV and this energy stored was transferred to the aluminium wire in the form of impulse. The wire is connected to the capacitor through a trigatron switch. When the triggering takes place ionization between the sphere gaps happens and the energy stored in the capacitor flows through the wire. It takes about 0.5s for

normal triggering action. After several shots of the explosion (about 40 to 50 shots), the colour of the distilled water changes to greyish black indicating the presence of nanoparticles.

At the completion of experiment the distilled water is collected in a bottle and the sub-micron particles are allowed to settle down. The sedimentation process can be performed using a centrifugal separator. Once the particles are separated they are characterized using SEM, TEM AND XRD analysis.

3.1 Characterization

Novel effects can occur in materials when structures are formed with sizes comparable to any one of many possible length scales, such as the de Broglie wavelength of electrons, or the optical wavelengths of high energy photons. In these cases quantum mechanical effects can dominate material properties. One example is quantum confinement where the electronic properties of solids are altered with great reductions in particle size. The optical properties of nanoparticles, e.g. fluorescence, also become a function of the particle diameter. This effect does not come into play by going from macroscopic to micrometre dimensions, but becomes pronounced when the nanometre scale is reached. The size and properties of the particles obtained are characterized by performing the SEM, TEM, and XRD analysis.

A scanning electron microscope (SEM) is a type of electron microscope that produces images of a sample by scanning it with a focused beam of electrons. The electrons interact with atoms in the sample, producing various signals that contain information about the sample's surface topography and composition. The electron beam is generally scanned in a raster scan pattern, and the beam's position is combined with the detected signal to produce an image. SEM can achieve resolution better than 1 nanometer. Specimens can be observed in high vacuum, in low vacuum, in wet conditions (in environmental SEM), and at a wide range of cryogenic or elevated temperatures [13].

Transmission electron microscopy (TEM) is a microscopy technique in which a beam of electrons is transmitted through an ultra-thin specimen, interacting with the specimen as it passes through it. An image is formed from the interaction of the electrons transmitted through the specimen; the image is magnified and focused onto an imaging device, such as a fluorescent screen, on a layer of photographic film, or to be detected by a sensor such as a CCD camera. TEMs are capable of imaging at a significantly

higher resolution than light microscopes, owing to the small de Broglie wavelength of electrons. This enables the instrument's user to examine fine detail even as small as a single column of atoms, which is thousands of times smaller than the smallest resolvable object in a light microscope. TEM forms a major analysis method in a range of scientific fields, in physical, chemical and biological sciences. TEMs find application in cancer research, virology, materials science as well as pollution, nanotechnology, and semiconductor research.

X-ray crystallography is a useful method used for identifying the atomic and molecular structure of a crystal, in which the crystalline atoms cause a beam of incident X-rays to diffract into many specific directions. By measuring the angles and intensities of these diffracted beams, a crystallographer can produce a three-dimensional picture of the density of electrons within the crystal. From this electron density, the mean positions of the atoms in the crystal can be determined, as well as their chemical bonds, their disorder and various other information.

4. RESULT

The discharge energy used in the experiment is 6 times larger than the vaporization energy of the wire (about 60kV to 70kV). Even with this energy there are still a large number of sub-micron particles still existing in the aluminium nano powder and we cannot say that all the wire has turned into Nano sized particles. Figure shows an abundance of submicron-sized particles existing in the produced Aluminium powder.

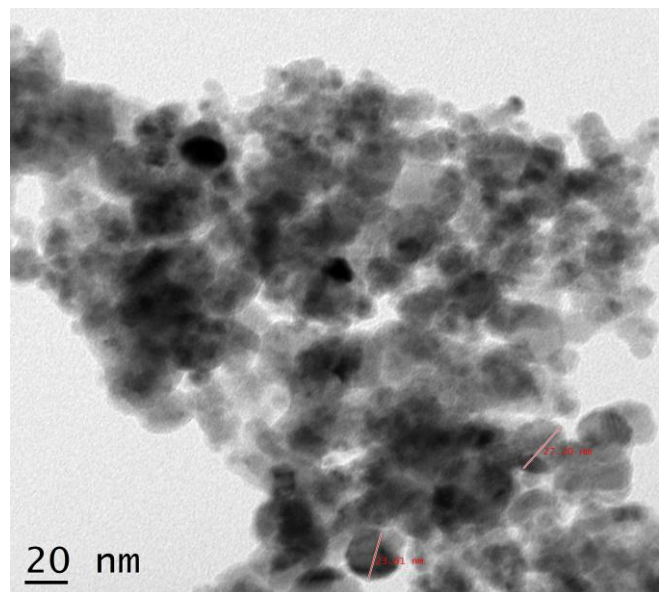

Fig-5: TEM result of sample

The presence of submicron sized particles is due to the very high vapour pressure during the explosion. Under very high vapour pressure, even though the energy deposition exceeded the vaporization energy of the wires because additional energy would be required to vaporize the inner part of the wire, the wire could not totally be vaporized. Therefore a little amount of the inner part of the wire still remained in a liquid state and finally the non-vaporized part was disintegrated into submicron - sized liquid droplets that leads to the submicron-sized particles formation. The Submicron - sized particles naturally settled down on time. However the speed of sedimentation can expedited by using a centrifugal separator.

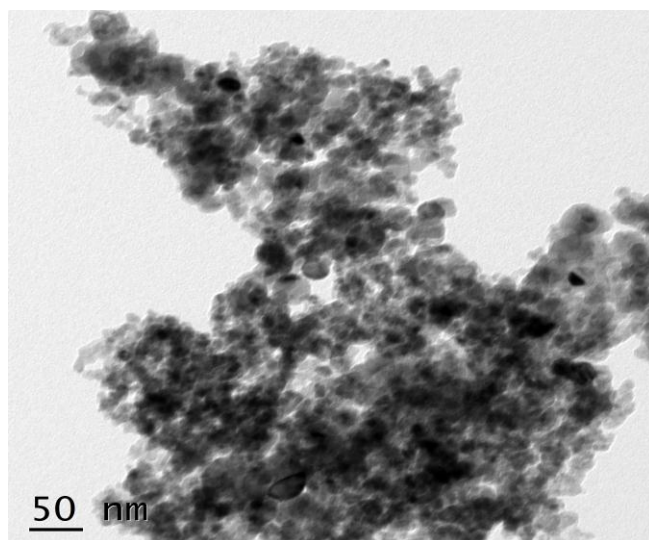
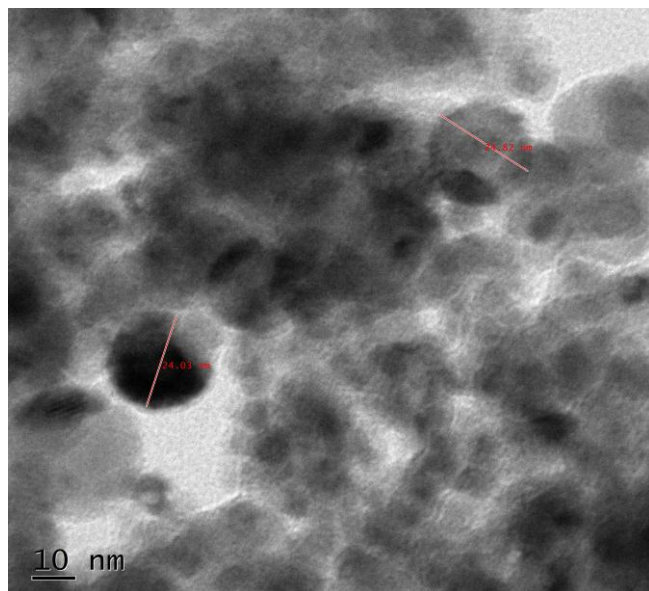

Fig-6: TEM Result for different magnification of the sample

For characterization, the samples after centrifugation is given for TEM and XRD analysis.

Figure 5 and 6 shows the TEM images of nano aluminium particles distinguished by using a centrifugal separator. The figures show the presence of nanomaterials. The size of the particles obtained belongs to the range of 20nm to 30nm. The particle distribution under different scales are also shown. The TEM analysis gives the particle size distribution at different magnifications as shown in figure.

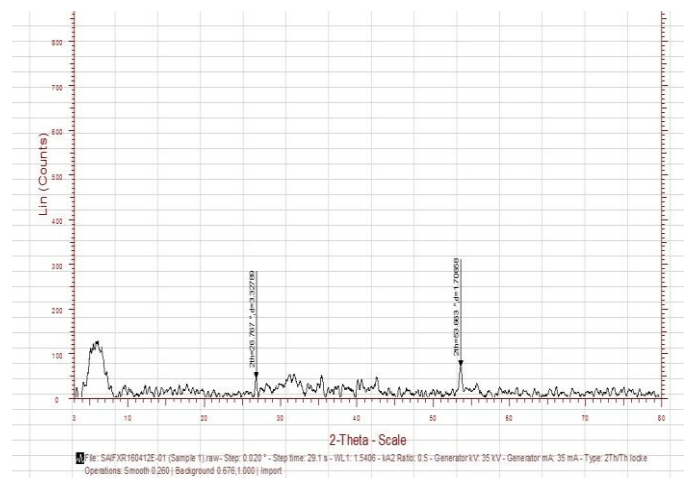

Fig-7: XRD result of the sample

Figure 7 shows the XRD result of the exploded sample. It gives the details about the grain size and particle distribution of the material. It is a useful analysis in determining the particle size distribution of the material and also useful in identifying the material.

5. CONCLUSION

Successfully exploded aluminium wires of .04mm diameter and 25mm length in distilled water at a voltage in the range of 60kV to 70kV, which is the voltage corresponding to 6 times the vaporization energy, to produce aluminium powders. The aluminium powder exhibited a wide sized distribution. The existences of large numbers of submicron sized particles were the result of un-vaporized metal droplets. Using a centrifugal separator the produced nano aluminium particles are distinguished. The size of Nano powder observed under TEM analysis had diameter between 20 to 30 nm. The particle size distribution of the sample was also found using XRD analysis.

REFERENCES

- [1] Aleyas MV, Madhu PM, Safwan Ahammed TKM, Nisham AT, "Production And Characterization Of Nano Copper Powder Using Electric Explosion Process In Liquid Media", *IJRET: International Journal of Research in Engineering and Technology* eISSN: 2319-1163 | pISSN: 2321-7308
- [2] R Sarathi, TK sindhu (2007), "Processing And characterization Of Nano Aluminium Powder", Department of electrical engineering IIT Madras, India.
- [3] Chuyhum Cho,Y choy and B.Kim (2010), "Preparation of nickel nanopowder by wire explosion in liquid media", *J.Nanopart*
- [4] Jung Yeul Yun, Y.A Kotov (2003), "Electric explosion of wires as a method preparation of nanopowders", *J.Nanopart*.
- [5] W.Jiang and K.jung Yeul (1998), "Analysis of electrical explosion of wire systems for the production of nanopowder", *IEEE Transactions on plasma science*.
- [6] Y Tokoy ,T Suzuki (2010), "Synthesis of Al nanopowder by pulsed wire discharge in nitrogen gas", *IEEE Transactions on plasma Science*.
- [7] Longchen Liu ,Qiaogen Zhang, Junping Zhaio, Wenyu Yan(2013), "Study on characteristics of Nanopowders Synthesized by Nanosecond electrical explosion of thin Al wire in the argon gas" , *IEEE Transactions on plasma Science*.
- [8] Drexler, K. Eric (1992), "Nanosystems: Molecular Machinery, Manufacturing, and Computation", New York: John Wiley & Sons. ISBN 0-471-57547-X.
- [9] Fultz, B and Howe, J (2007), "Transmission Electron Microscopy and Diffractometry of Materials", Springer. ISBN 3-540-73885-1.
- [10] Champness, P. E. (2001), "Electron Di_raction in the Transmission Electron Microscope", Garland Science. ISBN 978-1859961476.
- [11] Egerton, R (2005), "Physical principles of electron microscopy", Springer. ISBN 0-387-25800-0.
- [12] Zworykin VA, Hillier J, Snyder RL (1942), "A scanning electron microscope" , *ASTM Bull* 117, 1523.
- [13] McMullan, D. (2006), "Scanning electron microscopy 19281965", *Scanning* 17(3): 175185.
- [14] Smith KCA, Oatley, CW (1955), "The scanning electron microscope and its fields of application", *British Journal of Applied Physics* 6 (11): 391399.
- [15] McGrath, J.R. (May 1966), "Exploding Wire Research 1774 - 1963", *NRL Memorandum Report: 17*. Retrieved 24 October 2014.
- [16] Hansen, Stephen (2011), " Exploding Wires Principles, Apparatus and Experiments" , *Bell Jar*. Retrieved 24 October 2014.
- [17] Nazatenko, O (16 September 2007), "Nanopowders produced by electrical explosion of wires" , Dept. of Exology Tomsk Polytechnic University. Retrieved 6 November 2014.
- [18] Boysen, Earl, "Nanoparticles Applications and Uses", Retrieved 2 November 2014.
- [19] S. J. Chang; G. C. -C. Niu; S. M. Kuo; C. C. Ho; M. S. Bair, " Preparation of nano-sized particles from collagen II by a high-voltage electrostatic field system", *IEE Proceedings - Nanobiotechnology* Year: 2006, Volume: 153, Issue: 1
- [20] Jianping Li; Peng Mao; Fuliang Wang, " High concentration Ag nano-particles ink preparation and related writing system for paper-based writing electronics", *Electronic Packaging Technology (ICEPT)*, 2015 16th International Conference on Year: 2015
- [21] Shyh Ming Kuo; Shwu Jen Chang; Ioannis Manousakas; Li Chun Lin; Ting Wei Liu, " Preparation of Nano-Sized Collagen I and Collagen II Particles" , 2008 2nd International Conference on Bioinformatics and Biomedical Engineering Year: 2008 Pages: 1417 - 1419.
- [22] McMullan, D. (1953), "An improved scanning electron microscope for opaque specimens", *Proceedings of the IEE Part II: Power Engineering* 100(75):245256.