

Room Environment is Controlled in mobile for Industrial Application by Arduino

D. Naresh¹, B. Madhuri²

¹Student, Department of ECE, GIST college, Andhra Pradesh, INDIA

²Assistant Professor, Department of ECE, GIST college, Andhra Pradesh, INDIA

Abstract - In recent years there is a vast technology improvements in industrial control rooms for monitoring the entire field of Industrial plants. High end PLC's are being implemented for controlling the entire process of fields. But a problem is that even though automation takes the complete control of total plants few authentication and manual actions are needed from user side for completing the control action. Hence there is a must situation for users presence at all times in the control room for taking some timely needed control actions. Due to the static nature of control room environment, the user should always be static to monitor the process.. The proposed system does not require a dedicated server PC with respect to similar systems and offers a new communication protocol for monitoring and controlling the home environment with more than just switching functionality. Smart home interfaces and device definitions to ensure interoperability between ZigBee devices from various manufacturers of electrical equipment, meters and Smart Energy enables products to allow manufactured. Now the user in control room can be mobile at anytime, anywhere to monitor and control the whole plant. An arduino uno board is used here for acquiring process control parameters from the sensors and transmitting it via a Bluetooth module to an android device. Hence the parameter values can be monitored and stored simultaneously.

Key Words: arduino, android platform data logging, bluetooth, mobile control room, process control.

1.INTRODUCTION

Intelligent management of the power system, facilitate the joint use the current and minimizes power loss during transmission and power consumption is highlighted by the global community, academic institutions, and State administration. To gain full utility and customer protection dimensions, the idea of a smart grid enabling technologies used in In recent years, attracting a great deal of attention in the energy industry and academia Such studies. With continued growth in popularity and functionality of mobile devices, demand advanced mobile applications widespread human life continue to grow. The use of Web Services is an open and interoperable method for providing remote access

service or applications can communicate with each other. An attractive market for home. Automation and network of busy families and individuals will be physical Limitations. IBOARD is Ethernet Shield, and it was the smart Home micro web server. Arduino open source electronics prototyping platform based on Flexible, easy-to-use hardware and software. The Arduino IBOARD Microcontroller Board of Based on the IBOARD with 54 digital input / output pins. The Ethernet interface is Arduino Arduino via the SPI pins. Low-voltage switching relays were used to integrate Devices with Arduino is to show switching functionality. The LM35 temperature Sensor is used to control a smart home environment. A supervisory control system Intranet, low cost and high performance can react The ZigBee technology. An end node, the node sends data to the coordinator, and the coordinator Hub sends the data back to the terminal end of the loop. Since all devices have their own IP Address based on IPv6, they can be directly connected to an external network. So, all smart devices It can not only through the handheld remote control device to the central and local home, but can also be controlled remote computer control through the introduction of home Internet Gateway This document is template. We ask that authors follow some simple guidelines. In essence, we ask you to make your paper look exactly like this document. The easiest way to do this is simply to download the template, and replace(copy-paste) the content with your own material. Number the reference items consecutively in square brackets. However the authors name can be used along with the reference number in the running text. The order of reference in the running text should match with the list of references at the end of the paper.

1.1 Related Work

General smart home design Smart Home is applied in order to provide comfort, energy efficiency and better security. Smart Home System is still rarely used in Indonesia because of the cost and the difficulty of getting the device. The objective of this paper is to offer a Small Smart Home System designed and created by utilizing WLAN network based on Arduino microcontroller. The system is able to monitor and control lights, room temperature, alarms and other household appliances. Results from testing the system show proper control and control monitoring functions can be

performed from a device connected to a network that supports HTML5. Smart home network excite new possibilities. We proposed a new smart home energy management system based on ZigBee sensor networks to make home networks more intelligent and automatic in figure1. The role of the SHERMS for managing energy usage is a crucial factor in addressing the home's growing energy concerns. The Smart Energy initiative serves these needs by providing an adoptable and sustainable experience by linking new and useful digital technologies to the needs of consumers. By empowering consumers with near real-time information of their energy usage through an array of products and services, the intent is to help consumers use energy more efficiently and also to minimize their personal impact on the environment. We implement the proposed system and develop related hardware and software. We suggest new SHERMS based on the proposed system. We expect that our work contributes towards the development of ubiquitous home networks. As a part of future work, we will apply IEEE 802.15.4 standard technology in our home. Wireless sensor networks (WSNs) and power line communications (PLCs) are used in this work to implement a smart home control network.

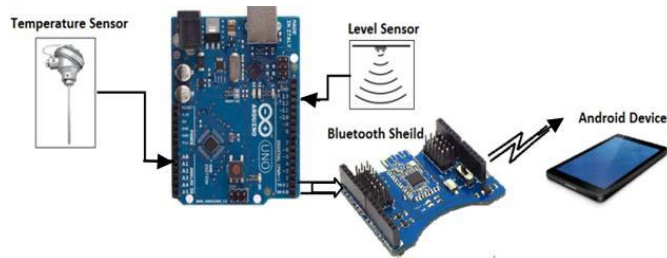

Fig. 1. Block schematic of the proposed system.

The block diagram of the proposed system is shown in Fig.1. In this work, two process variables like temperature and water level of a tank are taken for measurement with the help of Resistance Temperature Detector (RTD) and ultrasonic water level sensors. These sensors are attached to the real time temperature process control station. Here both temperature and level values are obtained directly as an electrical signal from the temperature process station. The RTD sensor used is of platinum type and finds its application for industrial purposes in measuring the temperature of a liquid. The ultrasonic level sensor is a non-contact type used for measuring liquid level in a tank. The sensors output obtained from temperature control station after proper signal conditioning is given to Arduino device for further processing. The Arduino device used here is an Arduino UNO board which comprises the controller, Bluetooth shield, Bluetooth serial module. The Arduino board contains the algorithm for communicating with the Android device through Bluetooth communication. The Android device has an algorithm to communicate with the Arduino device via Bluetooth as well as to store and display the results. The monitor screen on the Android device exhibits the real time values of level and temperature by displaying the values continuously and thereby helping the operator to monitor the values in the process environment in a movable manner.

2 HARDWARE USED IN THE PROPOSED SYSTEM

This section describes the technologies used for developing the mobile phone application of the Home Automation System. The mobile phone application development presented in this paper is based on the following technologies: Android, Bluetooth. Android is a platform for developing and deploying Android-based applications on mobile devices supporting it. Bluetooth has its own benchmark as a wireless communication technology for permanent and itinerant devices. Combining the power of Bluetooth, the best known and used wireless technology for short range communication, provides a facility to create Android-based mobile applications using the Bluetooth.

A. Arduino UNO

Arduino is a microcontroller board capable of performing very easy accessibility of the interacting environments. This board has a specially designed circuit board for programming and prototyping with microcontrollers. Arduino is an open source platform in which many real-time hardware components can be interfaced with greater compatibility. Also, any hardware or software upgradation is easily possible. The Arduino Uno shown in Fig. 2 is just a microcontroller board which is based on ATmega328. It has 14 digital I/O pins (where 6 can be used as PWM outputs), 6 analog inputs, one 16 MHz ceramic resonator, an USB connection, a power jack, an ICSP header, and a reset button. It comprises all necessary things required to support a microcontroller. It can be started just by simply connecting it to a computer with a USB cable or powering it with an AC-to-DC adapter or battery.

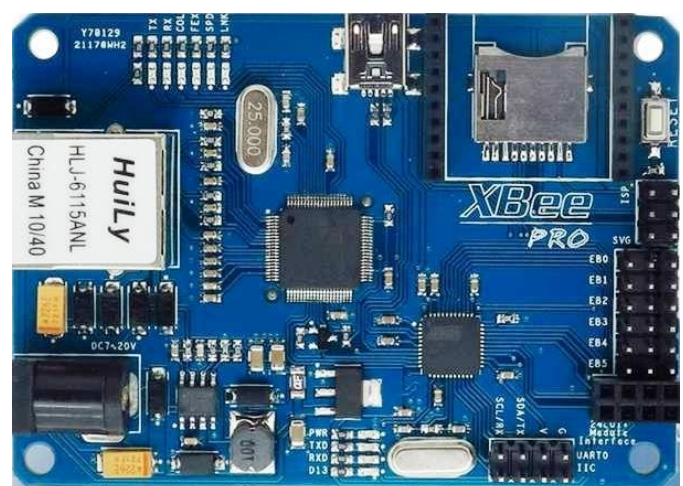

Fig. 2. Arduino UNO Board

B. Bluetooth Shield

Here the Bluetooth shield is used for the purpose of detaching the Arduino device from the Android device. By

having this shield, the android device can control or obtain the information from the arduino device with the help of touchscreen. This bluetooth shield integrates a blue tooth module and it is arduino compatible.

C. Bluetooth Module

The bluetooth module is contained within a Bluetooth shield. It is used easily with arduino for wireless serial communication. Here a serial bluetooth module is used for creating a connection between arduino uno and the android app. Also the Bluetooth module must be a slave type since all smartphones/tablets that are available today readily is of master type.

D. Temperature Sensor(RTD)

There are various types of temperature detectors available of which here an resistance temperature detector is used to sense the temperature. RTD is one amongst the temperature sensors which provides good accuracy, stability and reliability. Hence it is preferably used in most laboratories and industrial processes. In this proposed work a platinum RTD sensor has been used.

E. Ultrasonic Level Sensor

Ultrasonic sensors are non-contact type and also they are therefore insusceptible to the characteristics like scaling, corrosive & dirt environment, viscous fluids etc. This sensor which does not have any moving parts, emits ultrasonic pulses in the direction of the medium and gets reflected back. The time elapsed between emitted to received signal is proportional to the level in the tank. Thus ultrasonic transducer is based on the principle in which the time elapsed between the transmitted and received signal is directly proportional to the tank’s liquid level.

F. Android Smart Phone/Tablet PC

The tablet PC used for this proposed work is a commonly available android device having a 7 inch touch screen for a friendly interface with a screen resolution of 1280 x 800 pixels. It also has a WIFI / Bluetooth enabled running on an versatile open source android platform. This tablet comes with a loaded Android 4.2.2 operating system which has an expected enhanced performance and many good features. As this android device is very easily available everywhere it is considered for the proposed work.

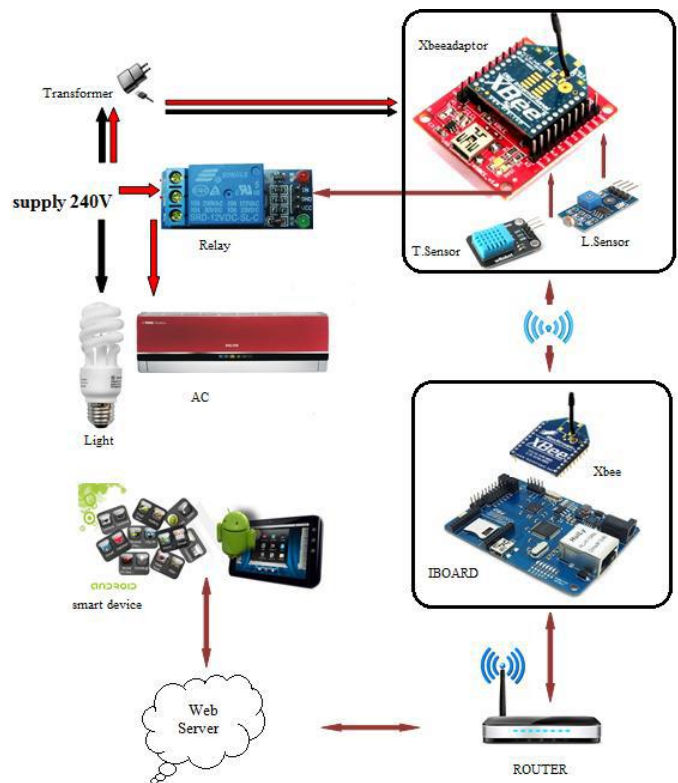

Fig.3. System architecture of Android Smart Switch system

3. SOFTWARES USED

The softwares used in this work have been categorized into two sections as mentioned below.

A. Eclipse IDE

Eclipse is an IDE suited for Java and many other programming languages such as C, C++, Fortran, COBOL, Python, etc. The Eclipse Integrating Development Environment (IDE) is used for the developing the android program so that an android application package can be created. Also by use of various plug-ins many applications can be developed in other programming languages. Eclipse IDE includes eclipse Java Development Tool (JDT) for Java developers and eclipse CDT for C/C++ programmers and so on. By installing plug-ins written for the Eclipse Platform, an user can write and contribute any required plug-in modules.

B. Arduino IDE

Arduino is an open source platform having a flexible, easy to use hardware and software which is helpful in creating interactive objects or environments. The arduino software or IDE runs on the computer and is used to write and upload the computer code to a physical board. Arduino integrated development environment (IDE) is a cross-platform application written in Java. It is designed to introduce

programming to any new programmer who is unfamiliar with software development. This includes a code editor with many features and is capable of compiling and uploading programs to the board in a single click. Arduino programs are written in either C or C++ and the coding written is called a sketch. The Arduino IDE comes with a software library that makes many common input/output operations very easier. Users are required to define only two functions called setup() and loop() to make a runnable cyclic executive program. The setup() is a function that once run at the start of a program initializes the settings while loop() is used to call repeatedly until the board powers off. There is a directory called hardware in which the arduino IDE contains the hardware-specific C libraries and other necessary configuration files.

4. ALGORITHM

The algorithm used in the proposed system has the following stages.

1. Collect the process parameters values of temperature and tank water level from different sensors using arduino board.
 2. Pair the Bluetooth module with a suitable android device.
 3. After pairing is completed, share the sensor data with the android device through Bluetooth shield on the basis of users' requirement.
 4. Visualize the sensor data in the screen immediately when the sensor data is received by android device.
 5. Login the sensor data values in the device through SQLite database after processing of the data.
- Hence the user can send back the process parameter values to the field through Bluetooth module and arduino device.

5. RESULTS AND DISCUSSION

In this section the results obtained from the proposed technique has been discussed. Here an existing real time process controller setup shown in fig. 4. has been taken for obtaining the temperature and level values from their respective sensors directly in electrical form.

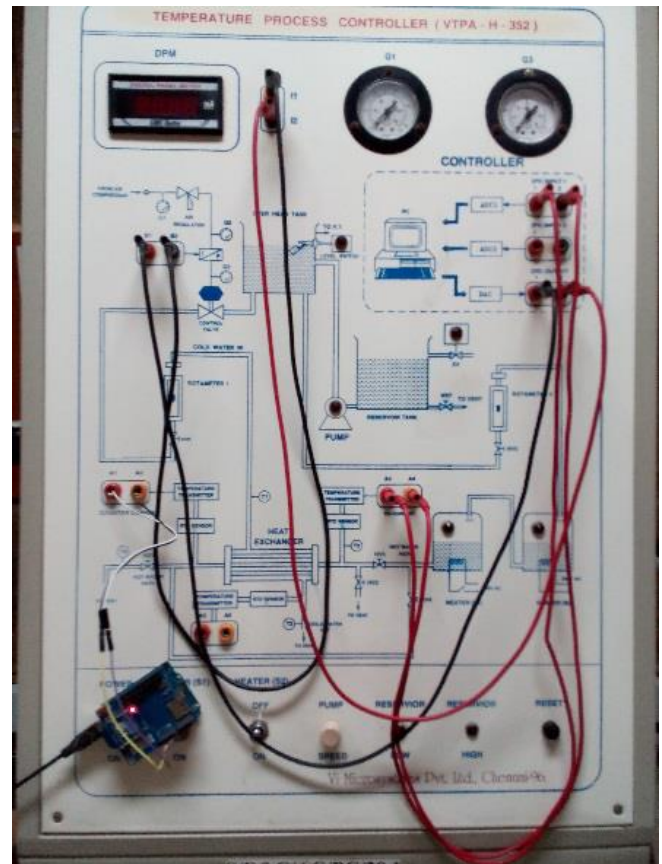

Fig. 4 Temperature process controller setup.

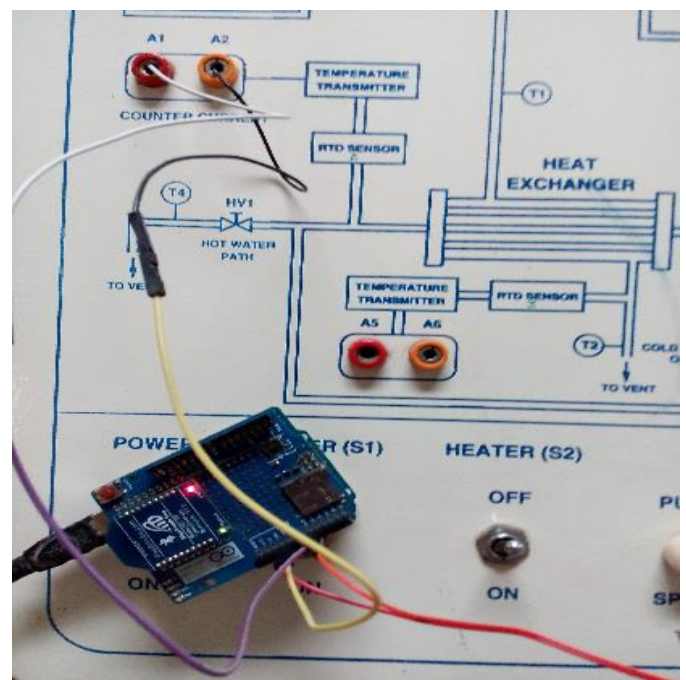

Fig. 5. Arduino device for acquiring the sensor output.

An arduino device is used to acquire the electric signals directly from the sensor output terminals of the temperature

process station. Fig. 5. Shows the temperature sensor output being connected with the arduino device where the arduino device is used for acquiring the sensor output values. The arduino device comprising the arduino board along with the bluetooth shield and serial Bluetooth module, communicates to the android device. Now the process data values are being transmitted from the arduino uno module to the android device where they are displayed on the screen as per the users' requirement.

6. CONCLUSION

The proposed system promotes the control engineer to obtain the data values anywhere and everywhere within the control room. This new system is suited for acquiring the control parameters like temperature and level process variables of an existing temperature process controller. Sensors acquire the data and with help of arduino-Bluetooth module the data values are transmitted to an android device where parameter values are stored in memory while simultaneously the user can view and analyze the readings obtained in real time. Hence the proposed system behaves like a good user friendly device of the control engineer as the user can always be mobile anywhere in the control room and also it doesn't require the person sitting in front of a panel display at all times monitoring the process. Here the process can be visualised in the screen of an ordinary android tablet. In general due to the use of arduino-android open source platform combination, enhancement and upgradation both in the hardware and software is easily possible.

ACKNOWLEDGEMENT

We the authors of this paper would like to gratefully acknowledge with thank B. Madhuri for explaining the changes made in the specifications we are grateful for many insightful comments about our specifications that helped us improve our paper. For constant encouragement and support for enabling us to submit this paper & to the management of Gandhiji Institute of Science and Technology, Jaggayyapet, Andhra Pradesh, India to have provided the laboratory facilities for development and execution of this project.

REFERENCES

- [1] A. H. Shajahan and A. Anand, "Data acquisition and control using arduino-android platform: Smart plug," International Conference on Energy Efficient Technologies for Sustainability (ICEETS), pp. 241-244, April 2013.
- [2] E.T. Coelho et al, "A Bluetooth-based Wireless Distributed Data Acquisition and Control System," IEEE International Conference on Robotics and Biomimetics, ROBIO '06., pp. 543 - 548, Dec-2006.

- [3] N.Suresh; E.Balaji; K.Jeffry Anto; J.Jenith4., "Raspberry Pi Based Liquid Flow Monitoring And Control" International Journal of Research in Engineering and Technology, Vol.03, Issue no.07, Jul-2014.

- [4] Dataloggers (Last accessed Dec 2014) [Online], http://www.webopedia.com/TERM/D/data_logging.html

- [5] R.Immanuel Rajkumar, "An approach to Implementation of Intelligent Data Acquisition Systems of Process Industries in Android Platforms," unpublished.

- [6] Ana Priscila Alves, Hugo Silva, Andre Lourenco and Ana Fred, "BITtalino: A Biosignal Acquisition System based on the Arduino," BIODEVICES 2013.

- [7] Arduino (Last accessed Jan 2015) [Online], <http://arduino.cc/en/Main/arduinoBoardUno>

- [8] A. I. Alexan, A. R. Osan and S. Oniga, "Assistme Robot, an assistance robotic platform," Carpathian Journal of Electronic and Computer Engineering 5 pp.1-4, 2012.

- [9] Jithin Krishnan, Niranjana D. Khambete and Biju B, "A Real time Data Acquisition and Monitoring Device for Medical Applications based on Android Platform," International Journal of Advanced Computer Research, Volume-3 Number-3 Issue-12 September-2013

- [10] T. Maria Jenifer, T. S. Vasumathi Priyadharshini, Raja Lavanya and S. Raj Pandian "Mobile Robot Temperature Monitoring System Controlled by Android Application via Bluetooth," International Journal on Advanced Computer Theory and Engineering (IJACTE), vol.2, no.3, 2013.

- [11] Android developers (Last accessed Jan 2015) [Online], <http://developer.android.com/sdk/installing/installing-adt.html>

- [12] M. A. Zermani, Elyes Feki, Abdelkader Mami, "Temperature Acquisition and Control System based on the Arduino," IJSE, Vol.02, Issue no.12, October 2014.
- [13] Gurpal Singh and Inderpal Singh, "Android os based wireless data acquisition system via bluetooth," IJRET, Vol.03, Issue no.06, June 2014.