

# Design, analysis and manufacturing of a grinding attachment on a center lathe machine

Abhishek M. Kawade<sup>1</sup>, Shreyansh S. Chougule<sup>2</sup>, Shantanu R. Shinde<sup>3</sup>, and Pratik P. Kharmale<sup>4</sup>

<sup>1</sup>Dept. of Mechanical Engineering, SKNCOE, Pune, India.

<sup>2</sup>Dept. of Mechanical Engineering, SKNCOE, Pune, India.

<sup>3</sup>Dept. of Mechanical Engineering, SKNCOE, Pune, India.

<sup>4</sup>Dept. of Mechanical Engineering, SKNCOE, Pune, India.

\*\*\*

**Abstract**—Cylindrical grinding is a process of grinding cylindrical workpieces. Special cylindrical grinding machines are available in the market which are quite huge and costly. For the grinding of the small workpieces, it is neither convenient nor affordable to use the special grinding machines. The objective of this project was to design and manufacture a compact, robust and economic grinding attachment for a center lathe machine which provides a surface finish of grade N5. All components were designed as per the deterministic method of design. After the design procedure was completed, finite element analysis was performed on the component which experienced worst loading conditions i.e. the shaft. Then some of the components were manufactured and some were selected from manufacturers' catalog and finally all parts were assembled. Then the attachment was tested on a lathe machine and the achieved surface finish value was measured.

**Index Terms**—Grinding attachment, Grinding, Surface finish

## 1.INTRODUCTION

Grinding attachment is a special attachment which is purposely made for the lathe to perform a grinding operation on the lathe. For small-sized cylindrical workpieces, it is neither economic nor preferable to use a special type of grinding machine for grinding operations. While in turning or facing process one can obtain surface finish of grade N8 with tool marks. But with this attachment, one can get a surface finish of grade N5 without tool marks and scoring marks.

This 'Grinding attachment' is simplest one. A self-contained grinding attachment employs a rigid housing having an electric motor for a grinding wheel. The shaft on which grinding wheel is mounted is connected to the housing by flexible and resilient connections thereby to isolate the grinding wheel from vibrations originating in motor lathe itself.

For cylindrical grinding, one need to have a cylindrical grinding machine which is big in size and costly too. Also one has to perform turning on lathe machine and then need to take work-piece to the grinding machine which consumes time. So it would be better and convenient to have a grinding

attachment which can be easily mounted on a center lathe machine.

So the objectives of the project are to:

- Design all components of grinding attachment
- Virtually validate the most critically stressed part.
- Fabrication of grinding attachment on lathe
- Testing of attachment
- Find the surface finish grade required

## 2.PROBLEM STATEMENT

The objective of our project is to design and fabricate a compact, robust and economic grinding attachment for a center lathe for small scale industries, small workshops, machine shops etc. which provides a surface finish of grade N5.

Following are the specifications of the attachment:

Model	GAL-204
Type	CYLINDRICAL GRINDING ON CENTRE LATHE
Weight	36KG
Peripheral speed	30m/s
Motor power(HP)	0.5HP
Wheel diameter	150mm
Voltage	220-240V
Frequency	50-60Hz
Grinding wheel type	STRAIGHT WHEEL TYPE
CNC	No
Recommended range of diameter of work piece	10-100mm

### 3.LIST OF COMPONENTS

**a. Grinding wheel:**

The grinding wheel used in this application is a straight wheel type grinding wheel. The signature of the wheel is as follows:

24-A-150-M-7-V

**b. Shaft:**

The shaft in this application is made of EN-9 alloy steel. The grinding wheel is mounted on the right-hand side and is mounted with help of washer. It is secured with fastener hexagonal nut. The shaft is supported by two bearings. The shaft pulley is mounted with the help of a washer on the left extreme of the shaft. Fig.1 shows the CAD model of the shaft.

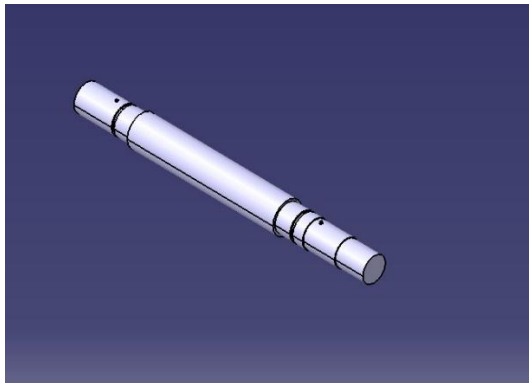

Fig.1. Shaft

**c. Shaft housing:**

The shaft housing houses the bearings, the shaft and other auxiliaries. It is a hollow cylinder in construction. It is made up of M.S.

**d. Bearing:**

The bearings used in this application are single groove deep ball bearings. These have been selected from SKF manual. The bearings selected are:

SKF 6023

OD=42mm

D=17mm

WIDTH=12mm.

**e. Belt and Pulley:**

In this application we have used two pulleys viz. one on the shaft side i.e. shaft-side pulley and other mounted on layshaft of the motor. A belt is a loop of

flexible material used to mechanically link two or more rotating shafts, most often parallel.

**f. Motor mounting plate:**

A Motor mounting plate is a plate on which the motor is secured with help of bolts. The motor mounting plate is made up of CAST IRON. This plate is further secured to the bottom housing with help of bolts. Fig.2 shows motor mounting plate.

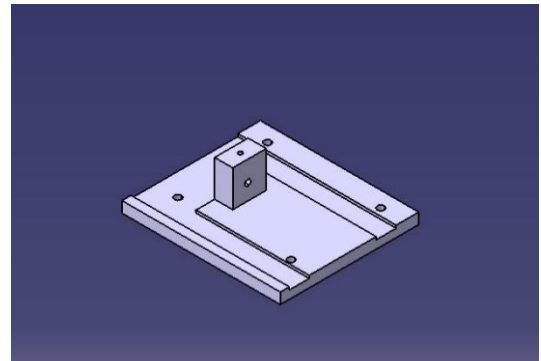

Fig.2. Motor mounting plate

**g. Bottom housing:**

This is the base of the attachment. It supports the whole structure. The bottom housing is split type in construction. It is a casted component made up of CAST IRON. Fig.3 and fig.4 show bottom housing

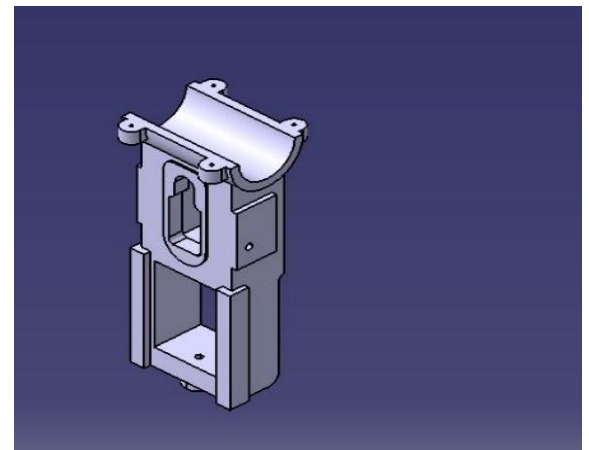

Fig.3. Bottom housing (A)

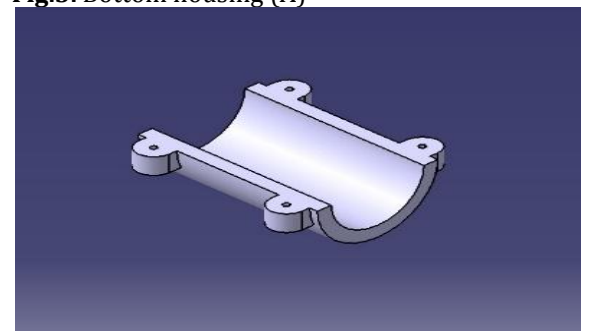

Fig.3. Bottom housing (B)

**h. Motor mounting clamp:**

The motor mounting plate is secured on the on the bottom housing with the help of motor mounting clamp. It is used so that the pressure due to fastening is equally and uniformly distributed. It is a casted component made up of cast iron.

**i. Belt guard and belt guard mounting:**

The belt and pulley arrangement are partially covered with the help of belt guard. This guard keeps the belt-pulley arrangement isolated from the surrounding. It is made up of M.S.

The belt guard is mounted on the base with the help of belt guard mounting. The belt guard is bolted to the belt guard mounting & the belt guard mounting is bolted to the bottom housing. It is made up of M.S.

**4.CONSTRUCTION OF ATTACHMENT**

Our designed 'Grinding attachment' is the simplest in construction. A grinding wheel is mounted on a shaft with the help of washer and nut. A shaft is fixed in a bearing. The bearings are mounted in the shaft housing. Bearings are fixed with the help of bearing caps. The total shaft assembly is mounted on the casted housing with the help of Allen bolts. At another end of the casted housing motor is mounted on the motor mounting plate. The Motor mounting plate is adjustable for belt tensioning. The drive is belt transmission from the motor to shaft pulley. The motor pulley and shaft pulley are fixed with keys on the motor shaft and shaft respectively. For protection belt drive and grinding wheel is covered with sheet metal guards.

**5.WORKING**

When the motor is switched ON, power will be transmitted from the motor to lay shaft. Through the belt drive power will be transmitted to the main shaft with a reduction in speed and amplification in torque. This tool attachment is mounted over the compound slide of lathe (tool post is totally removed). The job may be held between centers or in the chuck. The wheel is fed against the job. In grinding operation both job and grinding wheel rotate. Due to this conduct surface will get high degree finish. Here the feed is given by moving the carriage and depth of cut is given by cross slide. The automatic feed can also be given by back gear mechanism.

**6.VIRTUAL VALIDATION**

In our application, the shaft experiences worst loading conditions. Hence, we are going to perform a simulation of the shaft to check whether it operates without failure throughout its life. The figure below shows the FEA of the

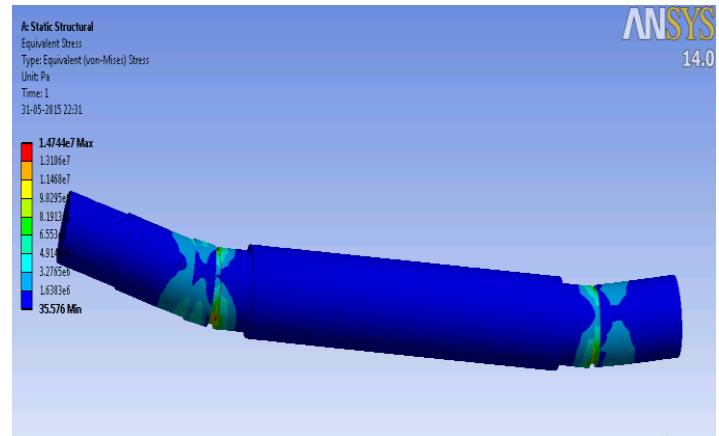

Fig.5. Total deformation of the shaft

shaft. The shaft was initially modeled using CATIA. The model was then analyzed using ANSYS, for bending giving suitable material properties and boundary conditions. In ANSYS, a meshed model was generated using the automatic method of meshing. The boundary conditions were then applied with a factor of safety of 5. The results so obtained show the shaft is safe. FEA of the SHAFT shows a high factor of safety in fatigue. Fig.5 shows the total deformation of the shaft.

**7.CONCLUSIONS**

The objective of this project was to design and fabricate a compact, robust and economic grinding attachment for a center lathe for small scale industries, small workshops, machine shops etc. which provides a surface finish of grade N5. All the components were designed as per the deterministic method of design. After the design procedure was completed, we performed FEA on the component which experienced worst loading conditions i.e. the shaft. The results showed that the shaft was safe under the various applied loads. Then we manufactured some components and some were selected from manufacturers' catalog (standard parts) and finally all parts were assembled. Then we tested our attachment on a lathe and measured the surface roughness value achieved. The surface roughness value was found to be 0.63 microns i.e. N5 grade surface finish, which was the required one. Hence, we have successfully fulfilled all the objectives stated:

- Design all components of the grinding attachment.
- Virtually validate the most critically stressed part i.e. shaft.

- Fabrication of GAL.
- Testing of attachment.
- Find the surface finish grade acquired.

## 8.ADVANTAGES

- **Low cost:** This attachment is simple in construction and uses simple belt drive transmission.
- **Minimum maintenance:** Due to lesser no of components and same being simple ones, the maintenance is low. Also, use of standard parts makes replacement of damaged or worn out part easy.
- **Lightweight:** Due to its compact nature it is light weight. It is a handy tool and can be carried easily where ever and whenever wanted. The place for storage required is also less compared to a special grinding machine.
- **Minimum operating cost:** It works on a 0.5HP motor. Hence the power consumption is also very less. This lowers the operation cost.

## 9.LIMITATIONS

- **Setup time:** It takes considerable time for mounting this attachment on a lathe.
- **Accuracy:** The accuracy and surface finish is less compared to a special grinding machine.
- **Limited operation:** Only cylindrical grinding operation can be performed using this attachment.
- **Productivity:** The speed of operation is lower than the special grinding machine. It takes more time to grind the same workpiece as compared to a special grinding machine

## 10.FUTURE SCOPE

A Direct, tool post mounting type grinding attachment would be an attachment which can be directly mounted on tool post of the lathe, like any other tool holders.

In grinding attachments used today, after the grinding operation, the attachment has to be physically removed for mounting the tool post. This is quite cumbersome & time-consuming.

Tool post mounting type grinding attachments can be mounted directly on the existing square or quick change tool post of a lathe, just like any other tool holder, without the need for removing the tool post. This will save the downtime in removing the tool post and mounting the attachment.

## 11.REFERENCES

- [1] P. S. G. design data book
- [2] Westerman table
- [3] Production Grinding-Fred B. Jacobs
- [4] Handbook of machining with grinding wheels-Ioan D. Marinescu
- [5] Principles of metal casting- Mahi Sahoo
- [6] Design of Mechanical Elements- V.B.Bhandari
- [7] Casting technology and cast alloys- A. K. Chakrabarti
- [8] Production Technology-HMT.
- [9] Hajra Choudhary, Workshop Technology-II
- [10] Finite Element Analysis - Theory and Applications with Ansys-Saeed Moaveni
- [11] Introduction to Finite Elements in Engineering-T.R. Chandrupatla and A.D. Belegundu