

# A High Static Gain Modified SEPIC Converter With PV Module and MPPT

Jayashri E. Patwardhan<sup>1</sup>, Ruchita Maheshwari<sup>2</sup>

<sup>1</sup> PG Scholar, Department of Electrical and Electronics Engineering, Marathwada Institute of Technology (MIT), Aurangabad, Maharashtra, India

<sup>2</sup> Assistant Professor, Department of Electrical and Electronics Engineering, Marathwada Institute of Technology (MIT), Aurangabad, Maharashtra, India

\*\*\*

**ABSTRACT** - Photovoltaic (PV) energy is one of the most important energy resources in renewable power generation since it is clean, pollution free, and endless. In photovoltaic (PV) systems to maximize the photovoltaic output power, Maximum Power Point Tracking (MPPT) is used irrespective the variations of temperature and radiation conditions. This paper presents two topologies of modified single-ended primary inductance converter (SEPIC) without magnetic coupling and with magnetic coupling for photovoltaic (PV) application. The single-ended primary inductance converter (SEPIC) is used in application with low input voltage and output voltage is considerably high. Proposed topologies based on modification of single-ended primary inductance converter (SEPIC) converter with voltage multiplier. With the proposed modification the static gain of the DC-DC Converter increases Both the topology provides the high static gain with the low switch voltage, reduce reverse recovery current of output diode for low input voltage renewable application. The two converters and MPPT algorithm were modeled using MATLAB/Simulink software for simulation. Simulation results show that both the topologies without and with magnetic coupling provides high static gain for renewable application with low input voltage.

**Key Words :** DC-DC converter, Voltage multiplier, PV Cell, MPPT, SEPIC

## 1. INTRODUCTION

Due to increasing electrical energy demand and limitation of fossil fuels; renewable power generation is the most importance in power sector. Low power wind turbine, photovoltaic (PV) modules are the some examples of renewable energy. The generation of energy in PV modules depended upon the environmental conditions, solar irradiation, module temperature.

To obtain the maximum power extraction to all environmental condition the maximum power point tracking (MPPT) is essential. Though the efficiency of module depends on the MPPT which force the module to operate with maximum efficiency.

To interface with utility grid the high static gain DC-DC converter to be used. There are many researches are going on to get high static gain dc-dc converters for applications supplied from low dc output voltage power sources. Applications like embedded systems, portable electronic equipment's, uninterruptable power supply, and

battery powered equipment required reduced losses, high power density, low weight, and volume.

The proposed converters can be used in the photovoltaic energy generation in grid-connected systems used in ac module or micro inverter structure. PV systems suffer from a major drawback which is the nonlinearity between the output voltage and current particularly under partially shaded conditions. However, the development for improving the competence of the PV system is still a demanding field of research. Generally, MPPT is adopted

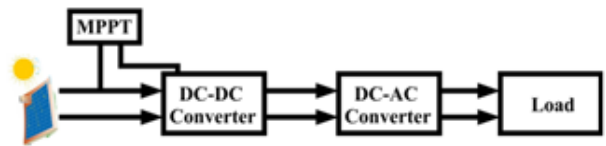
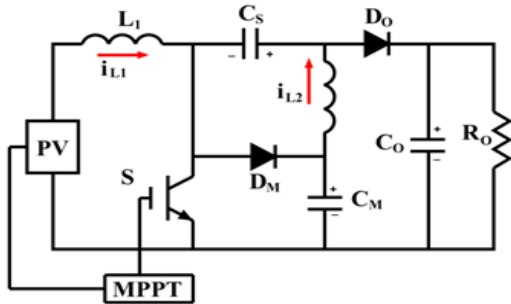

Fig.1 Two stage Ac Module Structure.

to track the maximum power point in the PV system. The P&O Maximum Power Point Tracking algorithm is mostly used because of its simple structures and fewer parameters. The conversion power is important to solar power generation systems because it converts the dc power generated by a PV array into ac power and feeds to ac power into the utility grid.

To obtain the DC voltage level necessary for the inverter operation and energy transferred to the grid with low-current harmonic distortion usually in high-power grid-connected photovoltaic generation PV modules are connected in series. Problem due this structure are, power losses due to the centralized maximum power point tracking (MPPT), mismatch losses among the PV modules, and generation reduction due to a partial shading of the series-connected PV modules. By using Multistring structure these problems can be rectified where reduced strings are connected with dc-dc converters with the MPPT algorithm and the output of these dc-dc converters are connected to the inverter input. For domestic based application most research is focused on the module-integrated converters where energy generated by the PV module is transferred to the grid through the high gain converter they can integrated with the PV module system. Such PV generation structure have advantages like modularity, allowing an easy increase of the installed power, the individual MPPT and reduction of the partial shading and panel mismatching effects, thus improving the energy-harvesting capability. But with these

structure some design challenges in ac module system are efficiency improvement, cost reduction, and the reliable operation throughout the module lifetime.



**Fig.2 Modified SEPIC Converter without magnetic coupling**

The ac module implementation is a two-stage topology as presented in Fig. 1. For the dc-dc converter due to the low input voltage, high input current, high output voltage, and static gain operation with high efficiency is critical. For the implementation of the first power stage high step-up ratio is necessary, the usual solution is the use of isolated dc-dc converters. The transformer turns ratio allows us to increase the converter static gain. However, the isolated solution presents some problems as the efficiency reduction due to the power transformer losses and intrinsic parameters as the leakage inductance. Use of power transformer increase the converter weight and volume.

Due to the high cost of the energy source, as photovoltaic module or fuel cells; The power converters used with renewable energy sources must present a high efficiency. The boost converter is the classical solution but its gives limited gain with duty cycle not more than 0.8. In this paper three static gain are considered; static gain equal to  $q = 5$  is limited. A dc-dc converter operating with a static gain range until  $q = 5$  is considered a standard static gain, a static gain range higher than  $q = 10$  is considered a high static gain solution and an operation with static gain higher than  $q = 20$  is considered a very high static gain solution.

The base topology presented in this paper is a modification of the SEPIC dc-dc converter with this modification we obtained operation characteristics with the requirements necessary in the high static gain applications. The without magnetic coupling structure gives static gain double of classical boost converter where as switch voltage half of the boost converter. In the structure with magnetic coupling secondary inductor acts as flyback transformer which increasing the static gain. Only part of power transfer through coupling inductor which reducing the stress on output diode, weight and volume of converter.

## 2. SEPIC CONVERTER WITHOUT MAGNETING COUPLING

### 2.1 Power Circuit without magnetic coupling

In fig. 2 the power circuit of modified SEPIC converter is present. The static gain of the SEPIC converter is an either step up or step down. In which the switch voltage is equal to the sum of input and output voltage. In some application the sum of the input voltage and output voltage is equal to the Switch voltage and static gain is lower than the classic boost converter. By adding two component i.e. diode and  $D_M$  and Capacitor  $C_M$  in the SEPIC converter. With this modification many characteristics are change with this converter. The static gain of the modified SEPIC converter is increased by double than classical boost converter with the high duty ratio. But practically the limitation of this converter is we cannot exceeds duty ratio above 0.85.

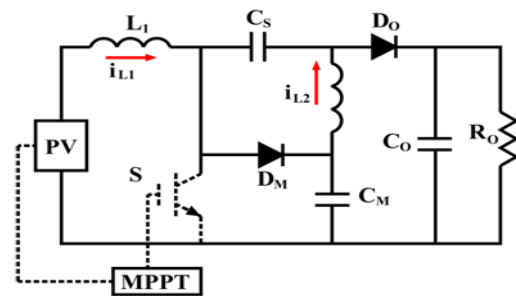

**Fig.3. First stage**

Consider converter CCM mode it includes two stages. For analysis assume all capacitors as a voltage source and semiconductors to be ideal.

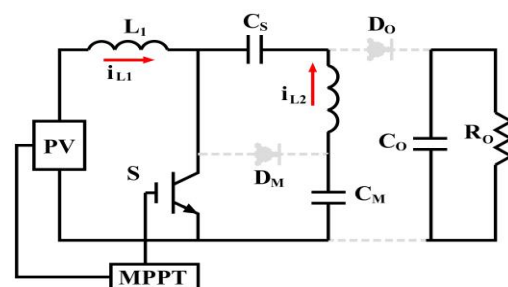

**Fig. 4. Second operation stage**

- 1) First Stage  $[t_0-t_1]$  (Fig.3) : In this stage switch S is turns-off at an instant  $t_0$  and the diode  $D_M$  and  $D_O$  are forward biased . The stored energy in  $L_1$  gets transfer to the output through the  $C_S$  and  $D_O$  and also it gets transfer to  $C_M$  through  $D_M$  . Due to this the switch voltage is equal to the  $C_m$  voltage. Energy stored in  $L_2$  gets transfer to output.
- 2) Second Stage  $[t_1-t_2]$ (Fig.4): In this stage switch S turns-on at an instant  $t_1$  the diodes  $D_M$  and  $D_O$  gets block and energy gets store in the inductors  $L_1$  and

$L_2$ . input inductor  $L_1$  charges with input voltage and inductor  $L_2$  charges with the voltage  $V_{CM} - V_{CS}$ .

The maximum voltage in all diodes and the power switch is equal to the  $C_M$  capacitor voltage. The sum of the  $C_S$  and  $C_M$  capacitors voltage is equal output voltage. Input current is equal to average  $L_1$  inductor current, and output current is equal to the average  $L_2$  inductor current. At the steady state the static gain of the proposed converter can be obtained considering null the average inductors voltage and it is presented in (1) considering the CCM operation. The static gain of the proposed converter is higher than the obtained with the classical boost.

$$\frac{V_o}{V_i} = \frac{D + 1}{D - 1} \tag{1}$$

$V_{CM}$  voltage is equal to the maximum switch voltage. The switch voltage is lower than the output voltage and calculated by (2)

$$\frac{V_{CM}}{V_i} = \frac{1}{D - 1} \tag{2}$$

Capacitor Voltage is Calculated by (3)

$$\frac{V_{CS}}{V_i} = \frac{D}{D - 1} \tag{3}$$

The operation stages and theoretical waveforms of proposed converter without magnetic coupling presented in this paper.

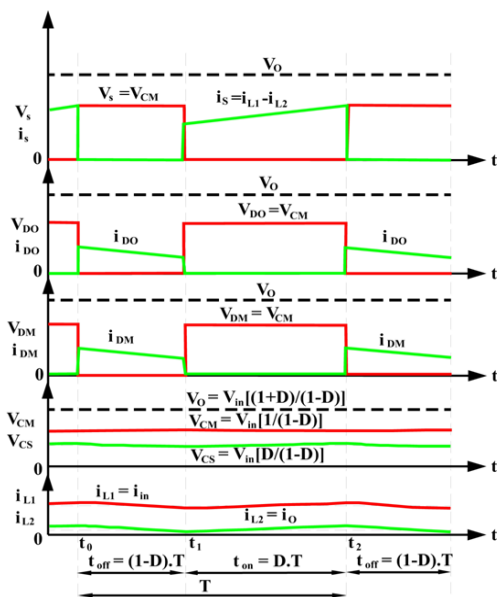

Fig.5 Theoretical waveforms

### 3. PROPOSED CONVERTER WITH MAGNETIC COUPLING

Power Circuit With Magnetic coupling

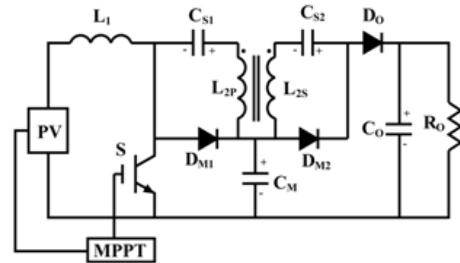

Fig.6 SEPIC Converter With Magnetic Coupling

Proposed converter shows double the Static gain with high duty cycle of conventional Boost Converter. However sometimes a very high Static gain is very necessary for certain application to maintain the converter performance steady at all operating conditions is the practical limitations. We cannot increase duty ration above 85% in practice. By adding secondary winding to inductor we can solve this problem. But by adding secondary winding the output voltage increase which cause overvoltage at output diode. This overvoltage is not controlled easily by conventional overvoltage protection. By providing the voltage multiplier at the secondary side can solve the problem. Employing voltage multiplier at secondary reduce overvoltage at output diode, energy transferred directly to output. Fig.6 shows the power circuit of proposed.

The CCM operation of modified SEPIC converter with magnetic coupling and output diode clamping having five operating stages.

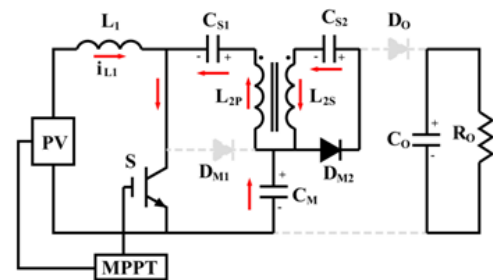

Fig. 7. First operation stage.

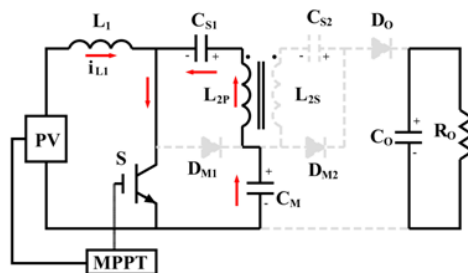

Fig. 8. Second operation stage.

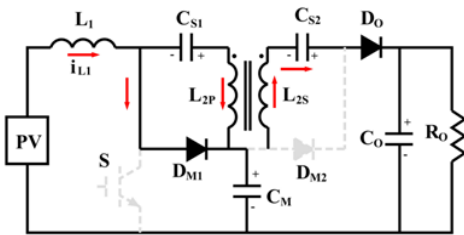

Fig. 9. Third operation stage.

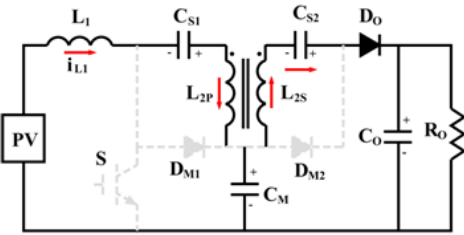

Fig. 10. Fourth operation stage.

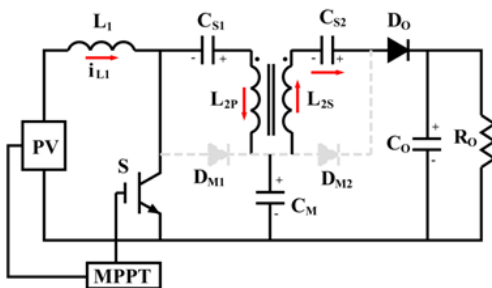

Fig. 11. Fifth operation stage.

1. First stage  $[t_0-t_1]$  (Fig.7): The Switch S is conducting secondary re leakage transfer in
2. Second stage  $[t_1-t_2]$  (Fig.8): The switch S is blocked from off. and the
3. Third stage  $[t_2-t_3]$  (Fig.9): The switch S is blocked from off. and the
4. Fourth stage  $[t_3-t_4]$  (Fig.10): At this time, energy get transfer to the capacitor  $C_M$ , and the diode  $D_1$  is blocked.
5. Fifth Stage  $[t_4-t_5]$  (Fig.11): When the Power switch is turn on at  $t_4$ , the current is linearly decrease  $D_0$ .

The main theoretical waveforms of the modified SEPIC converter with magnetic coupling and with the voltage multiplier at secondary side are presented in Fig. 12. The switch voltage and the voltage across the diode is low as compare to the output voltage. The switching losses are reduce when the switch get turn on. Due to the coupling

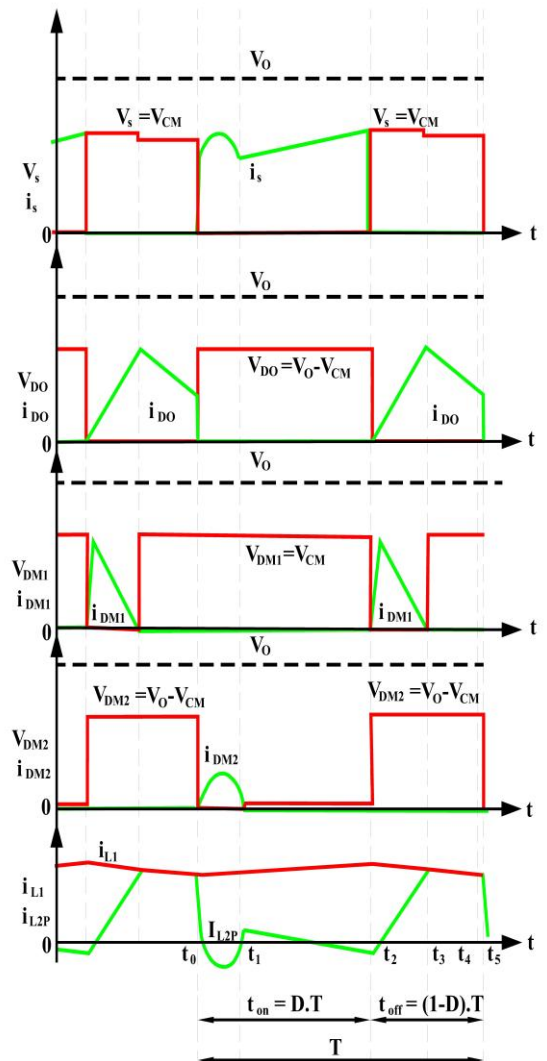

Fig. 12. Main theoretical waveforms of the modified SEPIC converter with magnetic coupling and voltage multiplier at the secondary side

inductor the current variations in all diodes, reducing the negative effect of the diode reverse recovery current.

The static gain of the modified SEPIC converter with magnetic coupling and voltage multiplier is calculated by (4).

$$\frac{V_o}{V_i} = \frac{1}{D-1} \cdot (1+n) \tag{4}$$

where the inductor windings turns ratio (n) is calculated by

$$n = \frac{N_{L2s}}{N_{L2p}} \tag{5}$$

#### 4.SIMULATION RESULTS

Using MATLAB /SIMULINK software model of single-ended primary inductance converter (SEPIC) without magnetic coupling and with magnetic coupling modeled and simulated. The parameters for preferred converter without magnetic coupling and with magnetic coupling are shown in table

##### Simulation results for without magnetic coupling

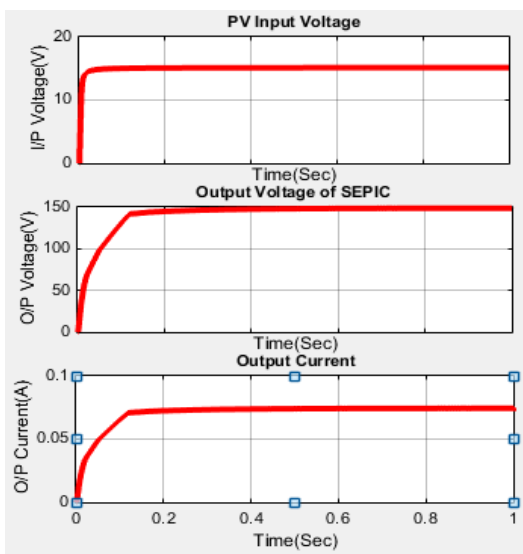

Fig.13 Input/Output Voltage, Current waveforms

##### Simulation results for with magnetic coupling

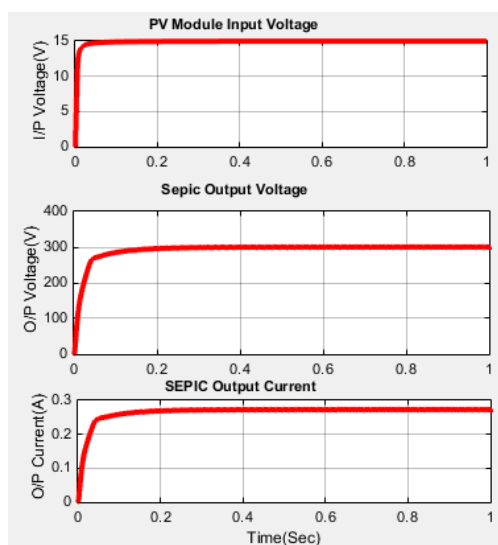

Fig.14 Input/Output Voltage, Current waveforms

Parameter used for simulation and design of converter are stated in table1 .

Table -1: Parameter

Parameters	Modified SEPIC converter without magnetic coupling	Modified SEPIC converter with magnetic coupling
Input Voltage(Vi)	15V	15V
Output Voltage(Vo)	150V	300V
Output Power(Po)	100W	100W
Switching Frequency(f)	24KHz	24KHz
Duty Cycle(D)	0.82	0.82
Switch Voltage(Vs)	83V	83V
Static Gain(q)	10	20

#### 5. CONCLUSIONS

The static gain of the proposed modified SEPIC converter without magnetic coupling is  $q=10$ ;where as with magnetic coupling and voltage multiplier is  $q=20$ . From the result obtain for without magnetic coupling and with magnetic coupling and voltage multiplier of proposed topology are giving high static gain for the renewable application with reduced switch voltage improved efficiency and reduced weight and volume.

#### REFERENCES

- [1] Roger Gules, Walter Meneghette Dos Santos, Flavio Aparecido Dos Reis, Eduardo Felix Ribeiro Romaneli, And Alceu Andre Badin,"A Modified Sepic Converter With High Static gain For Renewable Applications," IEEE trans power ele, vol. 29, no. 11, NOV 2014
- [2] C.Liu, B.Wu And R.Cheung,"Advanced Algorithm For Control Of Photovoltaic Systems," Canadian Solar Buildings Conference Montreal, August 20-24, 2004
- [3] A. Gupta, Y.K.Chauhan, R.K. Pachauri,," A comparative investigation of maximum power point tracking methods for solar PV system," Elsevier Solar Energy 136 (2016) 236–253
- [4] M.G Villalva, J. Rafael Gazoli, and Ernesto Ruppert Filho, "Comprehensive Approach to Modeling and Simulation of Photovoltaic Arrays," IEEE Trans. Power Ele., vol. 24, no. 5, pp. 1198–1208, May 2009.
- [5] D. Meneses, F. Blaabjerg, O. Garcia, and J. A. Cobos, "Review and comparison of step-up transformerless

topologies for photovoltaic AC-Module application," IEEE Trans. Power Electron., vol. 28, no. 6, pp. 2649–2663, Jun. 2013.

[6] D. Zhou, A. Pietkiewicz, and S. Cuk, "A Three-Switch high-voltage converter," IEEE Trans. Power Electron., vol. 14, no. 1, pp. 177–183, Jan. 1999.

[7] M. Prudente, L. L. Pfitscher, G. Emmendoerfer, E. F. Romanelli, and R. Gules, "Voltage multiplier cells applied to non-isolated DC–DC converters," IEEE Trans. Power Electron., vol. 23, no. 2, pp. 871–887, Mar. 2008.

[8] L.-S. Yang, T.-J. Liang, and J.-F. Chen, "Transformerless DC–DC converters with high step-up voltage gain," IEEE Trans. Ind. Electron., vol. 56, no. 8, pp. 3144–3152, Aug. 2009.

[9] Q. Zhao and F. C. Lee, "High-efficiency, high step-up DC–DC converters," IEEE Trans. Power Electron., vol. 18, no. 1, pp. 65–73, Jan. 2003.

[10] G. Henn, R. Silva, P. Prac,a, L. Barreto, and D. Oliveira, "Interleaved boost converter with high voltage gain," IEEE Trans. Power Electron., vol. 25, no. 11, pp. 2753–2761, Nov. 2010.