

Smart tolling for highway transportation system using RFID

Diksha Jadhav, Namrata Jadhav, Pratiksha Gunjal, Punam Gunjal

Department of Computer Engineering, Trinity college of Engineering and Research
Savitribai Phule Pune University, Maharashtra, India.

Abstract - Here we are simulating the Automatic toll system. It means that the user can pay the prepaid toll using the RF card. The money is automatically paid from the users bank as soon as the vehicle approaches the TOLL and user also get an acknowledgement SMS. If that vehicle is stolen vehicle then SMS will+ send to the police. The main concept of the project is to use the Toll booth user to pay his prepaid either from the users bank or the toll booth.

Key Words: Microcontroller, DC Motor, RFID Reader, RFID tags, IR Sensor

1.INTRODUCTION

Before some decade the toll booths were fully controlled by human. Means there are two persons for opening and closing of the gate and another two are for reception of the money and data keeping etc. Now only two persons are required for single booth. This system required less man power.

In this systems, the driver of vehicles don't need to stop at toll booth for paying a toll. The toll amount will get deducted automatically from owner account when he passes the toll booth . This RFID cards are connected to the owner account. So when vehicle come across the toll booths its reads the RFID tag of vehicles are deduct the toll amount from owner account .



Fig -1: Automatic TOLL collection system

This system will be having two advantages. First advantage is that the traffic at toll booth is managed automatically because vehicles do not need to stop at toll booth and pay the toll amount as a cash and take receipt because this process is very time consuming. Second advantage is that driver or owner don't need to carry the money every time. Driver will just keep some amount of money in his bank account and will use this RFID based card or tag each time he

travels. Many of the toll booths in India uses the toll collection system which operate manually. Currently traffic is increasing at toll booths on highways road are congested and heavily disturbed. It increases the traffic and wasting the time. The main goal of this system is to transformation of manual toll operations to automatic toll collection by using RFID technique.

1.1 Theft detection

In such a case if the vehicle is stolen that information is collected by the police department. The stolen database is collected by tollbooth. Whenever a stolen vehicle passes through tollbooth the automated message will be sent to the police department. After getting message from tollbooth police department will investigate further situation. By using this proposed system stolen vehicles can be searched.

1.2 Exception for special vehicles

Exception will be given to the special vehicles like Ambulance, Government authorized vehicles and motorbikes. Sometime ambulance may pass from tollbooth, in emergency is should pass from there without any obstacles. Same case for government authorized vehicles don't have to pay toll.

1.3 Return pass

Vehicle owner passes from tollbooth after midnight and return back till midnight. In such a situation vehicle owner don't have to pay new toll, the timer will count the hours and particular day of passing. Clock counter will decide that vehicle would pay fresh toll amount or returning toll pass amount.

2. Literature Survey

The automatic toll collection system by using RFID(Radio frequency identification reader) and passive RFID tag is solution for manual toll collection by reducing time and traffic jam[3]. Computer vision based detecting vehicles and collecting their TOLL using embedded Linux .Vehicle detection is done by using openCV library and camera. [2].RFID based automated toll plaza system is uses RFID technology and balance deduction is done at host machine and gate is automatically opened when toll is paid [1].TOLL

E-Ticketing system by using RFID techniques which automatically collects TOLL from vehicles when it cross the TOLL booth and message is send to the owner.

3. Proposed system Architecture

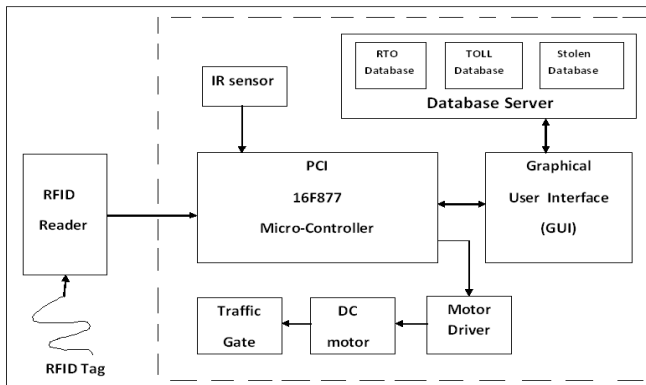

Fig -2: Architecture of proposed system

3.1 PIC Micro-controller

PCI means "peripheral interface controller". In our proposed system , PCI provides an interface to computer system to communicate with the peripherals such as RFID Reader, IR Sensor, Motor Driver. It takes data from RFID Reader give it to TOLL application running on our machine. It also take the input from IR Sensor and send it to the TOLL application running on machine. Output generated by an application (i.e. payment is done ,open the gate and close after 15 seconds) is given to the Motor Driver.

3.2 DC Motor

A DC motor is an electrical machines that converts direct current electrical power into mechanical power. DC motor is drives by motor driver and it is responsible for opening and closing the gate. It required low power and low voltage.

3.3 RFID Reader

RFID means "Radio frequency identification reader" is device used to gather information from RFID tag, which is used to track individual objects. Radio waves are used to transfer data from the tag to a reader.

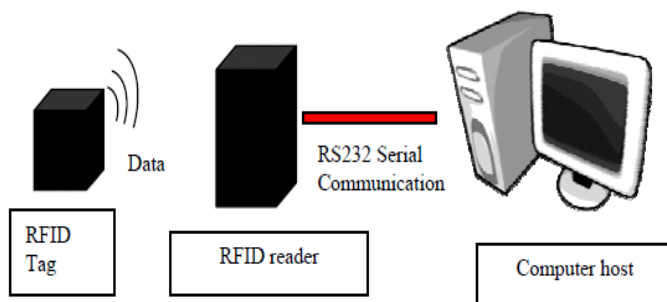

Fig -3: RFID Technique

In this system RFID reader is used to read RFID tag which is mounted on a vehicle. RFID reader gives us information related to vehicle and their owner. This information is stored into different databases.

3.4 RFID tag

There are two types of RFID tag are there passive and active RFID tag. In proposed system we are using passive tag which contains all the information of vehicles and their owners. The car can have only one tag attached to it. The owner may have one or more vehicles. RFID tag will contains all the information such as vehicle identification number(VID) etc. RFID tag with related information will be reducing wastage of time and extra money.

3.5 Database server

In this we are using three types of database are as follows:

3.5.1 RTO Database

This database contains registration information of vehicles from Regional Transport Office. When any person purchase a vehicle

3.5.2 TOLL Database

When a vehicle passes through TOLL booths then vehicle tag read by the RFID reader such as vehicle ID,vehicle type, Owner information etc. along with this other information is also stored in TOLL Databasesuch as time,date ,amount of toll payed and TOLL BOOTH at which toll is payed .

3.5.3 Stolen Database

When any vehicle is theft, the owner of vehicle register their complaint in near police station. This information is stored in Stolen Database and updated regularly. So When any vehicle come across a TOLL booth its information compared with stolen Database. If Match found then SMS is send to the police station where the complaint was registered.SMS contain the vehicle ID, Owner name, Owner contact number and TOLL booth address and where which direction the vehicle is goes. When the stolen vehicle is catch or found its entry from stolen database is remove.

3.6 IR sensor

IR sensor means infrared sensor. It is a device used to detect motion, speed and distance of a vehicle to decide whether the vehicle cross TOLL booth or not. This values are then pass to the application running on a client machine. According to this Traffic gate is opened and closed with the help of micro-controller and DC motor and driver .

4. Flow Control of Proposed system

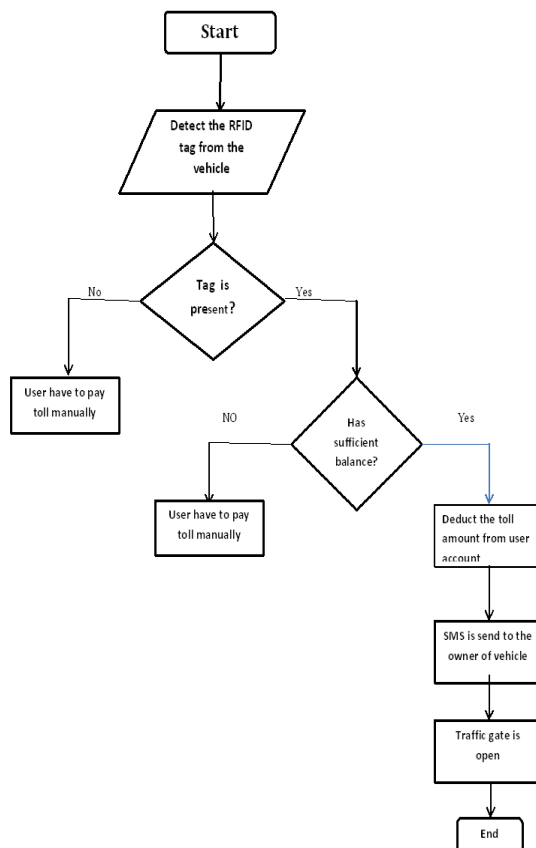

Fig -3: Flow control of proposed system

5. APPLICATIONS

1. Financial leakage control system
2. Investigation
3. E-cart shopping
4. Vehicle parking system

6. CONCLUSIONS

After developing automated of toll plaza we can have the solution over money wastage at toll plaza by deducting the extra manpower required for collection of money and also can deduct the traffic indirectly results in reduction of time at toll plaza. Also reduced accident rates because of its a totally automatic This automated system reviewed the research and development work for toll collection at the tollbooth gate on highway using RFID technique. By this system, the knowledge of RFID system, micro-controller, the database are defined.

By utilizing RFID based automated toll collection system, the vehicle will enable to check for security with the traveling time, save the time for toll collection and reduce traffic jam at the toll plaza. We can also close the gate using DC motor by pressing the switches. And process will be completed construction, Graphics User Interface(GUI) design and USB connection between PC and PIC using .Net language are

realized. Passive tags are better because of low cost, low power conduction and also radio signals environmental factors.

ACKNOWLEDGEMENT

We thanks to our teachers for their continuous support in this work and also for encouraging us for our new and aspiring ideas. We would especially thank Prof. Ranjeet Suryawanshi for guiding us through the process and being available for any problem we faced.

REFERENCES

- [1] W. H. Lee, B. S. Jeng, S. S. Tseng, and C. H. Wang, Electronic toll collection based on vehicle-positioning system techniques, in Proc. IEEE Int. Conf. Networking, SYNOPSIS Sensing, and Control, Taipei, Taiwan, R.O.C., Mar. 2123, 2004, pp. 643 648.
- [2] James J. Barbelllo. Handbook for parallel port design. Prompt Publications, 1999.
- [3] Andy Flessner. Autolt v3: Your Quick Guide. O'Reilly Media, 2007.
- [4] S. Hussain, et.al." Feature extraction of images from Corel database for similarity measurements "International Conference on Communication and Computer Vision 2013(ICCCV'13), Pg. No. 66-67 in Image processing and networking Domain on 20th and 21st December 2013 Organized by RVS Technical Campus, Coimbatore, India.
- [5] Hussain Asif, Dr. M. N. Giri Prasad and Dr. D. Satya Narayana "Superior Reconstruction Quality improvement of CT Image for Bias Correction Variance Measures"- International Journal of Computer Applications 2012- IJCA July 2012 Published by Foundation of Computer Science, New York, USA. , Proceedings in Volume 47 - Number 5 of IJCA July 2012 ISSN: 0975 1888 DOI 10.5120/7185-9918.
- [6] Hussain, et.al. "Prototype Model For Realistic Driving Environment System "International Conference on Emerging Technology Trends in Advanced Engineering Research(ICETT- 2012), Published by IEEE Press and in IEEE Explorer, pp 52 -57. Baseliious Mathews II College Of Engineering, Sasthamcottta, Kollam, Kerala, India, Feb' 20 th -21 st 2012(ISBN 978-93-80624-62-4).
- [7] Mohamed Mezghani "Study on electronic ticketing in public transport for EMTA" May 2008
- [8] Shaik Hussain et.al." An Intelligent Frame Work System For Finger Touch Association On Planar Surfaces " to be published in Springer LNEE and also Proc confer International Conference On Emerging Trends In Electrical, Communication And Information Technologies (ICECIT 2015), Dec19-21 2015,Ananatpur, India.
- [9] Ivan Gudymenko et.al. "A simple and secure e-ticketing system for intelligent public transportation based on NFC" Proceeding URB-IOT '14 Proceedings of the First International Conference on IoT in Urban Space ICST

(Institute for Computer Sciences, Social-Informatics and Telecommunications Engineering)ICST, russels,Belgium, Belgium 2014.

- [10] S.Hussain, et.al-" Accurate Face Recognition system based on ARM 9 processor using HAAR wavelets" International Journal of Engineering.