

Review of Free Energy Generator using Flywheel

Prof. Bharat M. Jibhakate¹, Jayant P. Karemore², Jitendra D. Jaiswal³, Kapil V. Kalambe⁴, Nilesh S. Zade⁵, Sitleshkumar K. Sonkalihari⁶.

¹Assistant Professor, J.D. C.O.E.M, Nagpur.

²³⁴⁵⁶Student, J.D. C.O.E.M, Nagpur.

Abstract

This Paper deals with the study of free energy and its generation using flywheel system. The energy storing capacity of flywheel is used to generate extra amount free energy. This extra energy is used to run s the other electrical appliances. It consist of A.C. motor of half horsepower capacity is used to drive a series of belt and pulley drive which form a gear-train and produces over double rpm at the shaft of an alternator. The intriguing thing about this system is that greater electrical output power can be obtained from the output of the alternator than appears to be drawn from the input motor. It is done with the help of Gravity wheel. The gravity wheel or flywheel is coupled with the gear-train in order to produce more extra energy or free energy. The overall study is done with various parameters of flywheel to obtain the maximum free energy out of the system. This free energy is getting free of cost.

Key words: Conventional Energy, Free Energy, Flywheel, Gravity, Power System, Generator

I.INTRODUCTION

Nikola Tesla once said that, all people should have energy sources for free to fulfil their daily needs . There is electricity everywhere present in limitless quantities and can drive the world's equipment without the need of non-renewable sources such as gas, coal or oil.

Free energy means the zero cost energy. Mechanical energy which drives windmill by using the blowing force of wind, or Solar energy in solar cell which is converts into DC current and store in batteries . Other energies obtained are from wind power, water power & telluric power. Free energy generator is used to generate these types of energy.

Free energy suppression is the notion that corporate energy interests intentionally technologies that may provide energy at minimum cost. All other remaining untouched forces of nature which are well familiar in the scientific literature, which includes earth batteries, atmospheric electricity, telluric currents, and pressure system changes.

The energy from continuous motion is considered fantastical forces. These devices utilize quantum

vacuum energy, quantum vacuum perturbation, magnets.

1.1 WORKING PRINCIPLE

The objective of this project is to recover energy of flywheel by using principle of energy recovery system from flywheel and produce sufficient energy to run the project set up and also some additional energy to run external power supply. The project process is inspired from CHAS CAMPBELL's Generator. An AC motor is starts with the help of AC supply. The shaft speed varies with help of pulleys with different diameters. After getting maximum speed at generator shaft, the initial AC input supply is replaced by the output supply of generator.

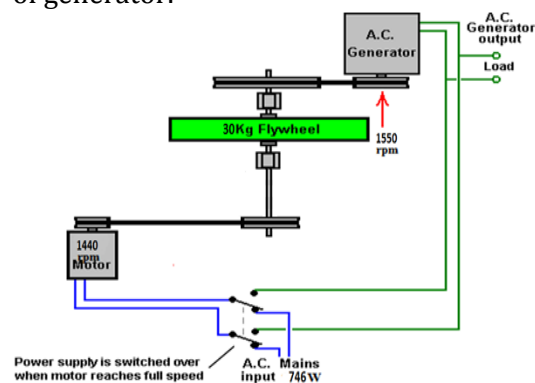

Fig. Layout of free energy generator

II. LITERATURE SURVEY

1. Self-Excited Induction Generator (SEIG) - A.K. Tandon et al., and Malik et al., [2][1987]:

In recent years, squirrel cage asynchronous motors are used as the electromechanical energy converter. The pri erate electricity. According to Tze-Fun (1888), an asynchronous motors called nciple of self-excitation applied to the asynchronous motors to gen as self-excited induction generator (SEIG), when a suitable capacitance is connected to across the stator winding of an induction machine and self-excitation occur under favourable conditions. SEIG is suitable candidate

for electric generation applications, because they do not need external power supply to produce the magnetic field. According to D. Seyoum et al. (2000) permanent magnet generator can also be used for energy applications but they pass from non-controllable magnetic field, which decays over a period due to weakening of the magnets, and generated voltage tends to steeply decreasing load. The advantages of SEIG over asynchronous induction machine are very small size and weight, simple construction, absence of separate source for excitation, cheap and low maintenance cost.

2. Analysis of Flywheel- Sudipta Saha, Abhik Bose, G. SaiTejesh, and S.P. Srikanth [4] [2009]:

The importance of the flywheel design specification selection and its contribution in the energy storage performance. This contribution is demonstrated on the example cross-sections using computer aided analysis and optimization procedure. This Proposed Computer aided analysis and optimization procedure results shows that suitable design of flywheel geometry design could both have a significant effect on the Specific Energy performance and minimize the operational loads exerted on the shaft/bearings due to reduced mass at high rotational speeds.

3. "A Flywheel-Based Regenerative Braking System for Regenerative Energy Recovery using flywheel by Tai-Ran Hsu:

This research paper represents a flywheel-based regenerative energy recovery system, storage & release system developed at laboratory. It can be recover and store regenerative energy produced by braking motion of generator with alternating rotary velocity such as the rotor of a wind turbo generator subject to not continuously intake of wind and the axels of electric automobiles during the frequent braking and coasting. Releasing of the stored regenerative energy in the flywheel by the alternator is easily transformed to electricity. A concept prototype called the SJSU-RBS, design, built and tested by students with able assistance of a technical workshops in author's college. A new regenerative braking system, the SJSU-RBS was developed with the design, construction and design of a proof-of-concept prototype. It involves a rapid spinning flywheel/alternator unit with a uniquely designed progressive braking system and an epicyclical gear train. This new SJSU-RBS can be readily allowed to power plants driven by renewable energies from alternating source such as solar, wind and hybrid gas-electric automobiles during braking & coasting.

4. Bedier B. EL-Naggar and Ismail A. Kholeif :

It had suggested that the disk-rim type flywheel for light weight. The mass of the flywheel is minimized subject to constraints sufficient moment of inertia and admissible stresses. The rotating disks of uniform thickness and density is applied to each disk and the rim is not dependent on suitable condition at the junction. Suitable boundary conditions of centrifugal stresses are applied. The dimensional ratios and design specification are obtained for minimum weight. It is proved that the required design specification is very close to the disk with uniform thickness.

III. CONCLUSIONS

We have obtained more electrical output which is our free energy. The AC generator have produce extra electricity by using of flywheel from 1 HP motor.

The main advantage of Free energy generator using flywheel is that it can generate energy without used of any extra equipment and this free energy generation is non-hazardous and environmental friendly.

Can be use in various applications like electric fuel cars ,household, industrial and increase the efficiency of traditional electrical.

IV. ACKNOWLEDGEMENT

The overall session of the project completion has been a more experience providing us with great insight into learning various design concept, software, engineering concepts & benefits of team work. As rightly said, for the successful completion of any type project, an effective & timely guidance is the very important asset. Our project would not have been materialized without the co-operation of many of the people involved.

V. REFERENCES

- [1] S.S. Murthy, O.P. Malik, A.K. Tandon, " Analysis of self-excited induction generators," Proc. IEE, Vol. 129, Pt. C, no.6, pp. 260-265, November1982.
- [2] Rocky Mountain Institute. "Regenerative Braking," Snowmass.
- [3] Cikanek, S.R. and Bailey, K.E. "Regenerative BrakingSystem for a Hybrid Electric Vehicle," Proceedings of the American Control Conference, Anchorage, AK, May 8-10, 2002.
- [4]. Uchiyama, T. and Yagami, H., 2004. vortex simulation for the interaction between a vortex ring.

[5] Tur, O., Ustun, O. and Tuncay, R.N. "Application Note on Regenerative Braking of Electric Vehicles as Anti-Lock Braking System," Ansoft Europe, French Office, [2005].and solid particles. Proc. 6th Int. Conf. Multiphase Flow, on CD-Rom.

[6]. Uchiyama, T. and Naruse, M, 2006. Three-dimensional vortex simulation for particulate jet generated by free falling particles. Chem. Eng. Sci. 61: 1913-1921.

[7]. Uchiyama, T. and Yagami, H., 2008. Numerical simulation for the collision between a vortex ring and solid particles. Powder Technol. 188: 73-80.

[8]. Lawrence A. Hawkins "Influence of Control Strategy on Measured Actuator Power Consumption in a Energy Storage Flywheel with Magnetic Bearings", 6th International Symposium on Magnetic Suspension Technology.

[9]. E. Anderson, M. Antkowiak, R. Butt, J. Davis, J. Dean, M. Hillesheim, E. Hotchkiss, R. Hunsberger, A. Kandt, J. Lund, K. Massey, R. Robichaud, B. Stafford, and C. Visser. "A Broad Overview of Energy Efficiency and Renewable Energy Opportunities for Department of Defense Installations".