

Paper on Smart Food Mixture Machine

Suraj Dhavalshankh¹, Vrushabh Sawant², Pratap Khade³, Vishnu Kambale⁴, Randhir Patil⁵

^{1,2,3}Department of E&TC, SGI Kolhapur, Maharashtra, India

^{4,5} Assistant Professor, Department of E&TC, SGI Kolhapur, Maharashtra, India.

Abstract - Food mixing, the process where two or more food items are mixed together is carried out manually. Manually mixing of these food items requires human requirement and it also takes lot of time. So in this project, a smart machine for food mixture is proposed. This machine is specifically designed to prepare **BHEL**. To prepare BHEL puffed rice, farsana, chili powder, tamarind liquid, some spices, onion has to be mixed with proper amount. These food items are taken automatically from the containers in which these above named food items are kept, according to the customers required quantity of plates and taste (i.e., sweet, medium spicy, spicy).

The required amount of above food items are taken, further the mixing of these food items is done at the mixing unit (i.e., steel container) which will mix all the food items and our ultimate intention of BHEL making is all done. All this process is controlled by the microcontroller.

Key Words: plastic parts, motors, pump, motor drive circuit, controlling circuit, power supply, mixing unit, keypad.

1. INTRODUCTION

In our day to day life food mixing, the process where two or more food items are mixed together is carried out manually. To make a good mixture (good taste) one requires good knowledge of foods to be mixed. Sometimes it is very critical to handle appropriate quantity of particular food items. Spices, salt, chillies, oil, water, sugar are the items which require critical handling. Food items can be semisolid (onion paste), crystalline (salt, sugar), powder (spices), granular (nuts, rice, wheat). Due to different formats of food items they are required to mix with proper handling process. An expert and experienced person's knowledge may require for this. What if we have a smart machine food mixing which will work to the micro level of taste and quantity? This may give

the solution for mixing the different food items with proper quantity for better taste.

In this project, a smart machine for food mixture is proposed. The machine will be specifically designed to prepare BHEL. To prepare BHEL puffed rice, farsana, chili powder, some spices, tamarind liquid, onion has to be mixed with proper proportion. In the proposed design, user can select taste (sweet, medium spicy, spicy) and quantity (no. of plates). Upon the inputs given by user smart machine will mix the required items in proper quantity.

To handle different food items specific plastic parts, containers will be designed. The complete system will be controlled by microcontroller. Appropriate user interface (keypad, display, motors, and pump) will be provided.

1.1 Plastic Parts-

These plastic parts are used for masala, farsana and puffed rice. These plastic parts are designed in solid works (software), after designing these plastic parts the design was given to 3D Printing Machine as input. According to the design the plastic part are made by 3D Printing Machine.

The material through which these parts are made is known as PLA material. PLA (PolyLactic Acid) is a biopolymer, i.e., a biodegradable plastic. It is made from renewable raw materials such as cornstarch or sugarcane. Aside from 3D printing, it is typically used for packaging material, plastic wrap, plastic cups and plastic water bottles. PLA materials are more environmentally among other plastic materials. The other great features of PLA are its biocompatibility with the human body.

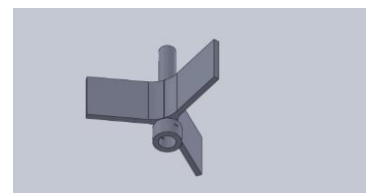

Fig. 1.1.1 Plastic Flap

This plastic flap with three blades as shown in fig.1.1.1 above is used in farsana and puffed rice plastic container which is placed in center of container. The motor shaft is connected to the flap. When motor is switched ON the flap starts rotating and as the flap rotates it takes the farsana over it and puts in to mixing unit.

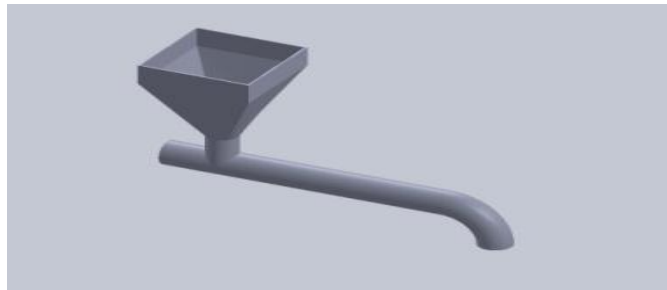

Fig. 1.1.2 Masala vessel

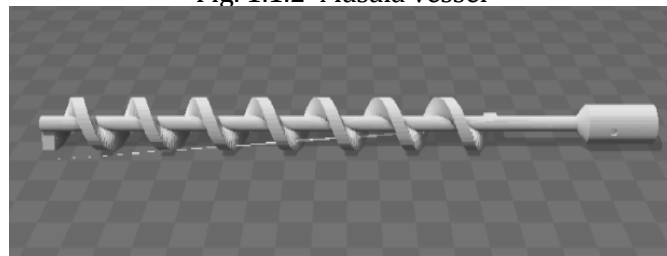

Fig. 1.1.3 Screw Conveyor

This part is design for masala in which the masala is kept filled shown in fig.1.1.2 above and the fig. 1.1.3 above is nothing but a screw conveyer, which is inserted in the pipe. Motor shaft is connected to screw conveyer. When motor is switched ON screw conveyer starts rotating and it convey the masala through it and masala is finally putted into mixing unit.

1.2 Motors-



Fig.1.2.1 DC motor

A geared DC Motor as shown in figure 1.2.1 has a gear assembly attached to the motor. The speed of motor is counted in terms of rotations of the shaft per minute and is termed as RPM .The gear assembly

helps in increasing the torque and reducing the speed.

This motor shaft is connected to the plastic parts. These DC motor operate on 12 volts dc supply



Fig. 1.2.2 Johnson DC geared motor

High performance DC geared Johnson motor with metal gear box used for high torque application and other automation purposes. The motor comes with 6mm off-centered shaft (side shaft) and M3 holes for mounting.

This Johnson DC geared motor is used for mixing the food items. This motor is connected to the mixer machine in the project.

1.3 Pump-



Fig. 1.3.1 Liquid Pump

A small DC submersible pump is used in the project for pumping the tamarind liquid. A submersible pump (or sub pump, electric submersible pump (ESP)) is a device which has a hermetically sealed motor close-coupled to the pump body. The whole assembly is submerged in the fluid to be pumped. The main advantage of this type of pump is that it prevents pump cavitation's , a problem associated with a high elevation difference between pump and the fluid surface. Small DC Submersible water pumps push fluid to the surface as opposed to jet pumps having to pull fluids.

1.4 Motor Drive Circuit-

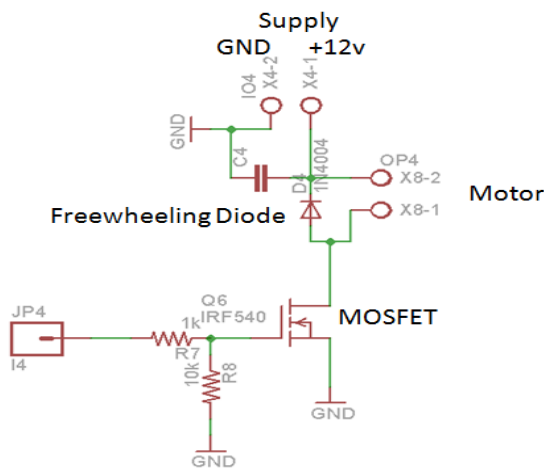

Fig. 1.4.1 Motor driver circuit

A "freewheeling diode" is put into a circuit to protect the switching device from being damaged by the reverse current of an inductive load. It is normally placed in a circuit so that it does not conduct when the current is being supplied to the inductive load.

When the current flow to an inductor is suddenly interrupted, the inductor tries to maintain the current by reversing polarity and increasing the voltage.

Without the "freewheeling diode" the voltage can go high enough to damage the switching.

With it, the reverse current is allowed to flow through the diode and dissipate.

1.5 Controlling Circuit-

The ATmega328 is a low-power CMOS 8-bit microcontroller based on the AVR enhanced RISC architecture.

The ATmega328 provides the following features: 32Kbytes of In-System Programmable Flash with Read-While-Write capabilities, 1Kbytes EEPROM, 2Kbytes SRAM, 23 general purpose I/O lines, 32 general purpose working registers, Real Time Counter (RTC), three flexible Timer/Counters with compare modes and PWM, 1 serial programmable USARTs , 1 byte-oriented 2-wire Serial Interface (I2C), a 6-channel 10-bit ADC (8 channels in TQFP and QFN/MLF packages) , a programmable Watchdog Timer with internal Oscillator, an SPI serial port, and six software selectable power saving modes. The Idle mode stops the CPU while allowing the SRAM, Timer/Counters, SPI port, and interrupt

system to continue functioning. The Power-down mode saves the register contents but freezes the Oscillator, disabling all other chip functions until the next interrupt or hardware reset. In Power-save mode, the asynchronous timer continues to run, allowing the user to maintain a timer base while the rest of the device is sleeping. The ADC Noise Reduction mode stops the CPU and all I/O modules except asynchronous timer and ADC to minimize switching noise during ADC conversions. In Standby mode, the crystal/resonator oscillator is running while the rest of the device is sleeping. This allows very fast start-up combined with low power consumption. In Extended Standby mode, both the main oscillator and the asynchronous timer continue to run

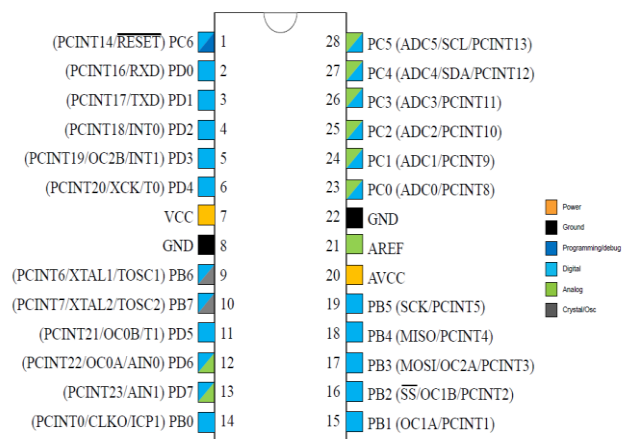

Fig 1.5.1 ATmega328 Controller

1.6 Power Supply-

Whole circuitry work on +5v & 12v DC power supply of 230v AC is applied to the transformer. By using transformer, rectifier, filters, IC regulators, etc. we get the desired output.

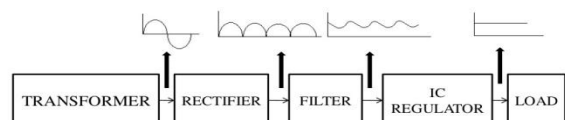

Fig 1.6.1 Power supply

1) Transformer:-

230v AC is step down to 5v and 12v as per requirement of circuitry.

2) Rectifier:-

It converts the AC supply into pulsating DC supply.

3) Filters:-

It removes the ripples from the DC supply which are coming from the rectifier.

4) IC regulator:-

IC regulator is providing the fixed DC voltage which load (i.e. relay and microcontroller) required.

1.7 Mixing Unit-



Fig. 1.7.1 Mixture Machine

As shown in the fig. above it is a mixing vessel in which all the food items will be mixed properly.

Inside the mixing vessel the blade assembly is used which will be responsible for the mixing of the food items properly when it rotates with the help of the high torque Johnson motor as the motor is fitted to the blades.

1.8 Keypad-

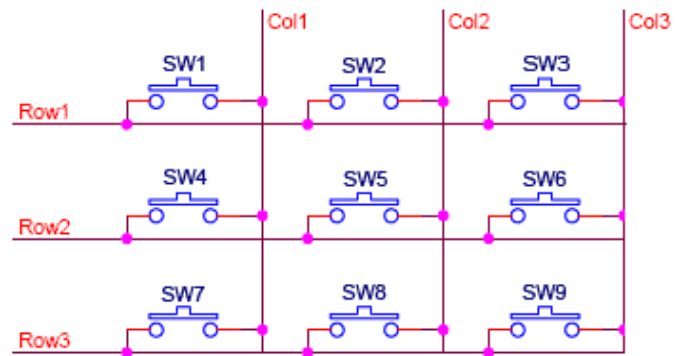

Fig. 1.8.1 Keypad

In this project we have provided a keypad which is used for input purpose. As shown in the fig. above is a matrix keypad. It can be connected to an arduino board so that numerical data can be entered by the user. Instructions exist in various forums on how to do this. The main problem is that this uses up a total of 6 of your digital inputs/outputs pins. On base of keypad are 6 solder terminals. Keypad can be considered to have 3 columns and 3 rows as shown in the fig. first step is to work out which solder terminal represents each row and which represents each column.

Write everything down as you go along, very easy to mix everything up. with the help of the keypad we can enter the no. of quantity of the BHEL, then the taste(i.e. sweet, medium spicy ,spicy) and the enter button is also present after pressing enter button the inputs which are given will be processed by the microcontroller by giving the signals to the motors.

1.8 Block Diagram-

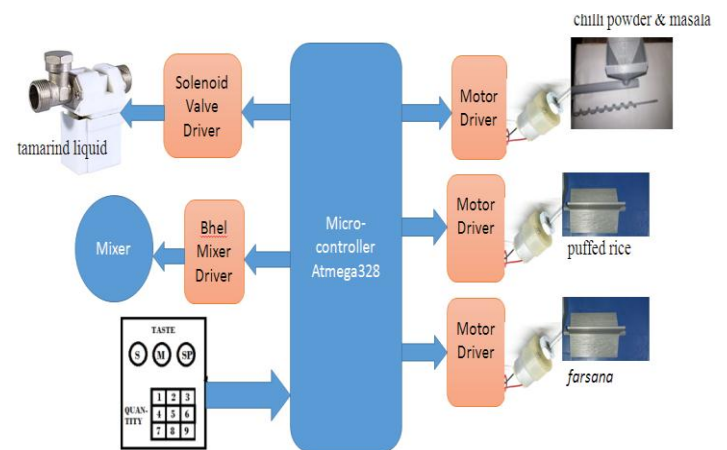

Fig. 1.8.1 Block Diagram

Above figure 1.8.1 shows specific block diagram for this project. Block diagram consists of microcontroller which is a heart of the project, keypad, motors, pump, plastic parts and mixer.

All these components are explained above in detail.

Algorithms-

We have used the algorithm explained below:

1. Initially inputs are given i.e. no. of quantity and taste.
2. Inputs are processed by microcontroller by giving electrical signals to the motors.
3. Depending on the inputs given respected motors associated with the different containers will start rotating for certain amount of time.
4. Further Food items which we are going to mix are being taken into mixing vessel.
5. Finally the all the food items are mixed in the mixing vessel.

Conclusion-

In this study, we have focuses on the design and implementation of an automated microcontroller-based bhel mixer that can provide mixed bhel with the push of a single button.

Acknowledgement-

It gives us immense pleasure in presenting the project report on '**Smart food mixture machine**'.

I would like to thank my internal guide Prof. V. N. Kambale for giving us all the help and guidance required for the project. I am really grateful to them for their support. Their valuable advice was also very helpful.

I am also grateful to Dr. S. R. Chougule, Head of Electronics and Telecommunication Engineering Department, SGI college of Engineering for her support, advice along with motivation for doing something innovative.

At last we would like to thank our college facility providing laboratory in charge for providing various resources such as laboratory with all needed software platforms, continuous Internet Connection, for Our Project.

References-

1. <http://www.alldatasheet.com/datasheet-pdf/pdf/392243/ATMEL/ATMEGA328.html>
2. <http://www.nex-robotics.com/products/motors-and-accessories/100-rpm-centre-shaft-economy-series-dc-motor.html>
3. <http://sproboticworks.com/products/johnson-gear-ed-side-shaft-motor-150-rpm---a-grade.html>
4. <http://www.kwsmfg.com/products/screw-conveyors.html> for screw-conveyor.
5. 3D Printing for Artists, Designers and Makers: Technology Crossing Art, Book by Stephen Hoskins
6. The AVR microcontroller and embedded systems using assembly and c. By Muhammad Ali Mazidi, Sarmad Naimi and Sepehr Naimi