

DESIGN AND SIMULATION OF GENERATION OF HIGH DC VOLTAGE USING COCKCROFT WALTON GENERATOR

Pankaj Bhutange¹, Nikita Hadke², Aditi Kathane³, Anirudha Marothiya⁴, Anurag Khergade⁵

¹UG Student [EE], Dept. of EE, S B Jain Institute of Technology Management and Research, Nagpur

²UG Student [EE], Dept. of EE, S B Jain Institute of Technology Management and Research, Nagpur

³UG Student [EE], Dept. of EE, S B Jain Institute of Technology Management and Research, Nagpur

⁴Associate Professor, Dept. of EE, S B Jain Institute of Technology Management and Research, Nagpur

⁵Associate Professor, Dept. of EE, S B Jain Institute of Technology Management and Research, Nagpur

Abstract- This work describes the details of high voltage D.C. power supply where output is 2 kV, whereas its input voltage is 230 V of sinusoidal waveform. In this study, we have designed a prototype of high voltage power supply and simulation work has been done by using MATLAB Version 7.0 software.

Key words -Cockcroft Walton Generator, high voltage DC, wave shaping resistor, MATLAB

1. INTRODUCTION

There are many uses of high voltage DC power supply. High DC voltage is mainly used in the industries where the requirement of high dc power is necessary. High DC voltage power is widely used in research work in the field of applied physics and for testing purpose in industries. High voltage is used for dielectric and insulation testing of electrical equipments at power frequency. There are many applications of High voltage DC power in electrical engineering such as electron microscope, x-ray, electrostatic precipitators, particle accelerator, etc[1]. Dielectric behaviour of electrical equipments can be tested by giving high voltage DC supply as a input to them, where the surviving capacity of equipment can be tested at all conditions. The voltage given to the equipment should be greater than the normal DC voltage to find out equipment's sustaining capability of voltage and decide the voltage margin for the particular equipment.

The circuit Cockcroft Walton generator or voltage multiplier is an electric circuit which generates DC power at high voltage. This circuit was discovered much earlier by Heinrich Greinacher in 1919[1]. The circuit got named after the British and Irish physicist Jhon Douglas Walton and Earnest Thomsan Walton, who first used this circuit in 1932 to power there particle accelerator [1].

In this paper, the main importance is given on designing of Cockcroft Walton Generator circuit, simulation and its hardware implementation. It is a six stage voltage multiplier circuit having 230V AC as an input supply and 2 kV DC as an output voltage. The entire work is categories into two main stages. First stage deals with generation of high DC voltage using multiplier circuit and second stage deals with conversion of high DC voltage into standard pulse. After completion of both stages on MATLAB platform, hardware implemented of circuit is done in the laboratory.

2. VOLTAGE MULTIPLIER CIRCUIT

As the name suggests, the Cockcroft-Walton is a voltage multiplier circuit which has a multiplication factor of two [5]. A voltage multiplier is an electrical circuit that converts low AC voltage into high DC voltage. It is made of a voltage multiplier ladder network of capacitors and diodes to generate high voltages.

The voltage multiplier however, is a special type of diode rectifier circuit which produce an output voltage greater than the applied input voltage. In most of the cases voltage multipliers are same as rectifier as they convert AC to DC voltages which can be use in electrical and electronic circuit applications such as in microwave ovens, high voltage test equipments etc where it is necessary to have very high DC voltages generated from a low AC supply.

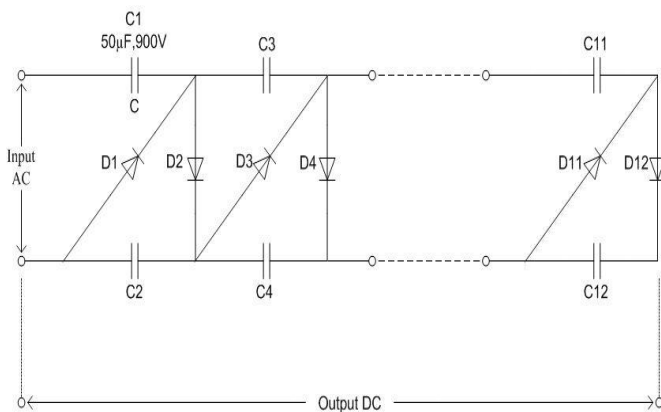

C=Capacitor

D=Diode

Fig -1: Basic voltage multiplier circuit

The above circuit shows a basic multiplier circuit which consist of two half wave rectifier circuits. Through addition of second diode and capacitor, we can increase its output voltage, such type of voltage multiplier is known as a full wave series multiplier as one of diode is conducting in each half cycle as same as full wave rectifier.

2.1 Working of Voltage Doubler Circuit

When the sinusoidal input voltage is positive, capacitor C₁ charges through diode D₁ and when sinusoidal input voltage is negative, capacitor C₂ charges through diode D₂. The output voltage 2V_{IN} is taken across two series connected capacitors. In the same way the entire circuit is energized and we can calculate the DC out put voltage across the final stage by using the formula

$$V_o = n \times 2 * V_{peak}$$

By reversing direction of the diodes and capacitors in the circuit,we can also reverse direction of output voltage creating negative peak voltage.

3. DESIGN CRITERIA :

The design criteria describe the selection of different elements. This includes selection of number of stages for required output, selection of capacitors, selection of diodes & selection of wave shaping resistors.

3.1 Selection of Number of Stages

Here , we have to select number of stages in a Cockcroft Walton voltage multiplier circuit to get a desired output level. Therefore the selection of stages should be accordance with required output voltage & the voltage drop till last stage.

The equation for calculating the number of stages is given below,

$$n = \frac{V_{out} + V_{drop}}{2 * V_{peak}}$$

Where,

n=Number of stages

V_{out}=Output Voltage

V_{drop}=Voltage drop till last stage

V_{peak}=Input peak voltage

If we gets the value in fraction in above equation then consider the nearest greater integer for selection of number of stages.

3.2 Selection of Capacitors

Generally, the size of capacitors used in the Cockcroft Walton multiplier circuit is directly proportional to frequency of its input voltage. For the frequency of 50 Hz, the capacitors are used usually in the range of 1 to 200 µF [10]. Similarly for high frequency as 10 kHz, the capacitors are used in the range of 0.02 to 0.06 µF [10]. Voltage rating of a multiplier circuit is selected on the basis of type of multiplier circuit. It should be capable of withstanding the maximum voltage depending on the number of stages. It is better to select the capacitor of voltage rating twice (approximately) that of input voltage i.e. if the input voltage is V_{max} then the capacitor should have voltage rating of 2V_{max} [10]. Here, we have used two capacitor of 100 µF, 450 volts each. These two capacitors are connected in series to have effective capacitance of 50 µF, 900 V in each stage.

3.3 Selection of Diodes

Selection of diode depends upon maximum reverse voltage across the diode i.e. peak reverse voltage. This peak reverse voltage is present in every diode therefore we have to select the diode voltage rating 2V_{max} for the safety purpose [1]. We have selected the IN4007 diode for our setup. The voltage rating of this diode is 1000 volts and current rating is 1 ampere.

3.4 Selection of Wave Shaping Circuit

We are obtaining the impulse wave of our output voltage. In order to obtain the impulse waveform from desired output voltage, we requires a wave shaping circuit i.e. switching circuit which consist of a wave front resistor R1, wave tail resistor R2 and a capacitor C2. The design of a wave shaping circuit (switching circuit) is shown in below figure.

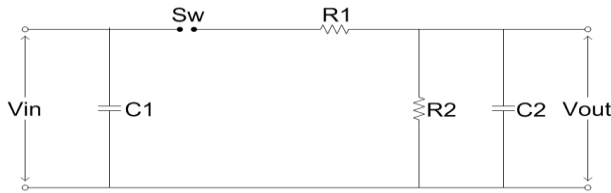

Fig -2: Basic Switching Impulse Circuit

Where,

- Sw= Switch
- C1= Effective capacitance of the circuit
- C2=Load capacitor
- R1=Wave front resistor
- R2=Wave tail resistor

According to Indian standard Specification 1.2/50 μ sec wave is considered to be the standard impulse [9]. The tolerance allowed in the peak value is $\pm 3\%$. The tolerance that can be allowed in the front and tail times are $\pm 30\%$ and $\pm 20\%$. In standard impulse wave 1.2 μ sec is front time and 50 μ sec is tail time [9].

- **Front/ Rise Time (t1):-** It is the time required by impulse wave to attain the peak value.
- **Tail/ Fall Time (t2) :-** It is the time required by impulse wave to decay to 50% of peak value after attaining the peak value.

4. SIMULINK MODEL :

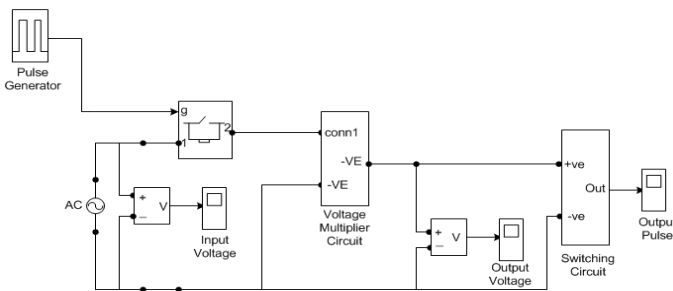

Fig -3: MATLAB Model of Generation of High DC voltage using Cockcroft Walton

Fig.3 shows the simulink model of Cockcroft Walton impulse voltage generator.

4.1 Voltage Multiplier Circuit

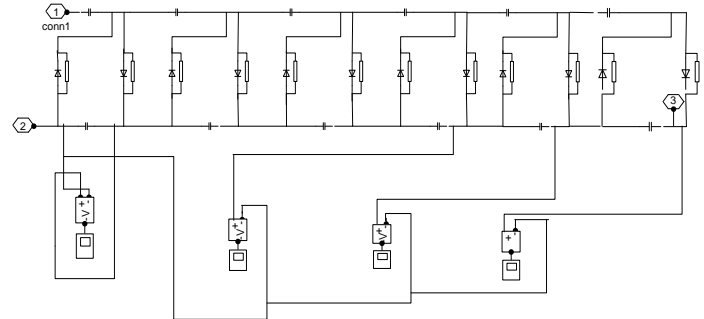

Fig -4: MATLAB Model of Voltage Multiplier Circuit

Fig.4 shows the working and stimulation of Subsystem1 VOLTAGE MULTIPLIER CIRCUIT.

The voltage multiplier circuit is a special type of diode rectifier circuit which produce an output voltage greater than the input voltage. We uses voltage transformer to increase a voltage but there are many possibilities that it may unavailable so that time one easy way is to use a voltage multiplier circuit [11]. In this research voltage multiplier circuit is specially use for very high DC voltage generated from a low AC supply. Generation of high voltages is mainly required in research work in the areas of pure and applied physics. There are various applications of high DC voltages in industries, medical sciences etc. The most efficient method for generating high DC voltage is by the process of employing voltage multiplier circuit.

Table -1: Circuit Parameters

Parameters	Ratings
Generator Capacitors	50 μ F
Load Capacitor	83.3 nF
Wave Front Resistor	4.8499 Ω
Wave Tail Resistor	3.64 Ω

Above table shows the ratings of circuit parameters used for simulating the impulse voltage generator.

4.2 Comparison of Simulation Results With Expected result

To demonstrate the stimulation of the project, the results obtained from simulations are match up with those expected results. Fig.4 shows 6-stage Cockcroft Walton impulse voltage generator. This set will be used for testing of high voltage and can also be used as prime high voltage DC source and charging unit for impulse generator. The stimulation works can be incorporate by implementing and testing the circuit in the laboratory. The input voltage to Cockcroft Walton Voltage Multiplier circuit was set to a specific figure and its output voltage obtained from 6 stage Cockcroft Walton Voltage Multiplier circuit as shown in fig.4. The main advantage of Cockcroft Walton Voltage Multiplier is, it converts low AC input voltage to the high DC output voltage. Generally the Cockcroft Walton Voltage Multiplier is made up of network of capacitor and diodes. Generation of very high DC voltage from low level AC input while at the same time being far lighter and cheaper than transformers.

Table -2: Comparison of Simulated and Expected Result

Charging Voltage (V)	Maximum Impulse Voltage Magnitude (V)	
	Expected Result	Simulated Result
20 V	150 V	148 V
230 V	2000 V	1996 V

5. Results

Below figures shows the various waveforms which are obtained from the simulation of 6-stages Cockcroft Walton Generator circuit.

5.1 Switching Pulse

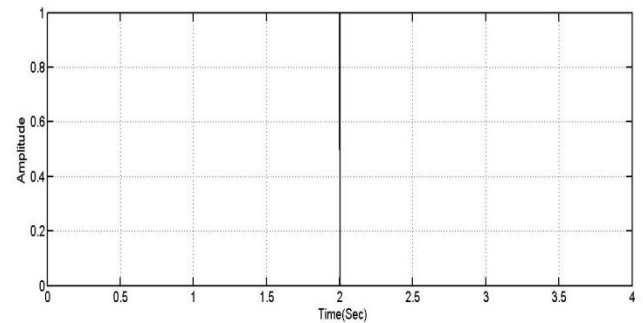

Fig -5: Switching Pulse Waveform

Fig.5 shows the switching impulse waveform which is to be given to our 6-stage Cockcroft Walton Generator circuit. The time taken for switching is 2 seconds.

5.2 AC Input Voltage

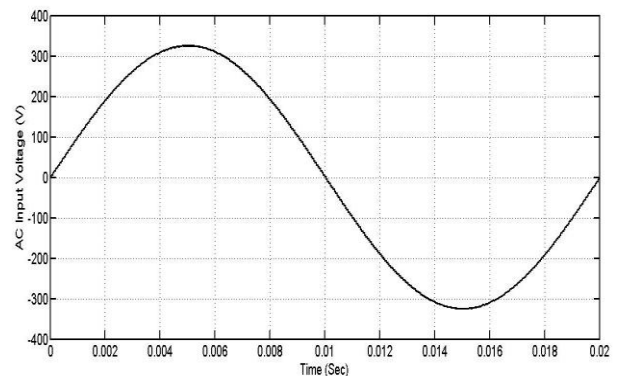

Fig -6: AC Input Voltage Waveform

Fig.6 shows the AC input voltage waveform. In our simulation circuit, we are giving 230 volts AC input voltage whose peak RMS value is 325.96 volts which is shown in fig.6. This figure is showing first cycle of AC input voltage.

5.3 DC Output Voltage

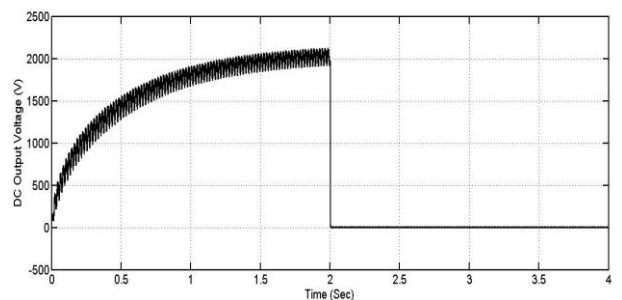

Fig -7: DC Output Voltage Waveform

In this 6-stages Cockcroft Walton Generator circuit, we are obtaining 2 kV DC output voltage waveform after giving 230 volts AC input.

5.4 DC Impulse Voltage

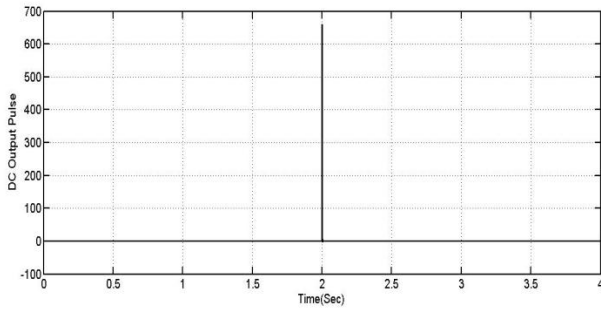

Fig -8: DC Output Impulse Voltage Waveform

Fig.8 is showing the DC output impulse waveform. In this pulse rise time is 1.2 μ Sec and the fall time is 50 μ Sec. These rise time and fall time are standard time according to Indian Standard Specification.

6. Effect of change in wave shaping resistance and load capacitance over the performance of impulse output voltage

The simulation software is used to explain more about the effect of change in various parameters over the performance of 6-stage Cockcroft Walton voltage multiplier and also the effect of wave shaping resistors over the performance of impulse voltage generator. The resulting outputs for these circuits are shown in tables below.

Table -3: Effect of change in load capacitance on impulse voltage

C2(Farad)	Voltage(V)
8.33×10^{-8}	665.3
8.33×10^{-9}	660
8.33×10^{-10}	665.72
8.33×10^{-11}	665.80
8.33×10^{-12}	665.83

Table -4: Effect of change in wave front resistor (R1) on impulse voltage

R1 (Ohms)	Voltage(V)
4.8	663.41
4.9	700
5.0	690
5.1	680
5.2	675

Table -5: Effect of change in wave tail resistor (R2) on impulse voltage

R2(Ohms)	Voltage(V)
3.64	659.57
3.7	667.5
3.8	678.6
3.9	689.5
4	700

Above tables shows the influence of the wave shaping resistors and load capacitance over the performance of the impulse voltage generator. It can be seen that, with increase in the values of wave shaping resistors, the output voltage wave takes longer time to obtain the peak magnitude and also reduces towards zero with slow rate. Moreover, with increase in the resistor values, the output voltage also reduces. The same impulse voltage generator not only use for the generation of over voltages of shorter duration but also for generating the longer duration.

7. CONCLUSIONS

- The following conclusions could be made from this work:- From the simulation, it is noted that a MATLAB based design for high voltage D.C.

power supply at 2 kV output has been designed and developed..

- Cockcroft-Walton Voltage multiplier circuit is used when higher magnitude of output high voltage DC power supply is required without changing the input transformer voltage level. Mainly this circuits are used for testing purposes.
- This kind of high voltage DC power supply test circuit is of simple in control, low cost, portable due to its light weight. Different magnitude of High voltage DC output can be taken from different stages
- The advantages of this circuit are that it has high reliability, light weight, economical and capability to produce different magnitude of high voltage DC output at different stages.

REFERANCES

- 1) International Journal of Science and Technology Education Research Vol. 2(7), pp. 109 - 119, July 2011. C. K. Dwivedi¹ and M. B. Daigavane department of Electrical and Electronics Engineering, Disha Institute of Management and Technology, Raipur-492101, India. ²College of Engineering, Sewagram (Nagpur), India.
- 2) IEEE Recommended Practices and Requirements for Harmonics Control in Electric Power Systems, IEEE Std. 519, 1992
- 3) Ramleth Sheeba, Madhavan Jayraju, Thangal Kunju and Nediya Shikam Shanavas, Simulation of Impulse Voltage Generator and Impulse Testing of Insulator using MATLAB Simulink, World Journal of Modelling and Simulation, Vol.8, pp. 302-309, 2012.
- 4) International journal for scientific research and development vol. 2 issue 12, 2015. Multi purpose DC high voltage generator using Cockcroft Walton voltage multiplier circuit Mr. sachitanand s. Tijare¹, Mr. Gaurav D. Thakare², Mr. rahul P. Argelwar³. 1,2,3 department of Electrical Engineering COET, Dhamangaon.
- 5) International journal of science, Engineering and technology Research and technology Research (IJSETR), VOL.4 issue 2, February 2015. High voltage generation using Cockcroft Walton Multiplier Nikhil M. Waghmare, Rahul P. Argewar.
- 6) Joseph (2001) presented his paper as the basic operation of multiplier circuit such as half wave voltage doublers circuit, and discussed guide lines for electronic components selection for diodes and capacitors.
- 7) IEEE Transactions on Dielectrics and Electrical Insulation (Volume: 20, Issue: 1, February 2013)
Page(s): 147 - 156
Date of Publication: 11 February 2013
Print ISSN: 1070-9878
- 8) IJSRD - International Journal for Scientific Research & Development| Vol. 2, Issue 12, 2015 | ISSN (online): 2321-0613 All rights reserved by www.ijsrd.com 821 Multi-Purpose DC High Voltage Generator using Cockcroft-Walton Voltage Multiplier Circuit Mr. Sachitanand S. Tijare¹ Mr. Gaurav D. Thakare² Mr. Rahul P. Argelwar³ 1,2,3Department of Electrical (Electronics & Power) Engineering 1,2,3DES's COET, Dhamangaon (Rly)
- 9) International Journal of Computer Applications (0975 - 8887) International Conference on Innovations In Intelligent Instrumentation, Optimization And Signal Processing "ICIIOSP-2013" 1 Simulation and Implementation of Single-Phase Single-Stage High Step-Up AC-DC Matrix Converter based on Cockcroft-Walton Voltage Multiplier

BIOGRAPHIES



Pankaj D. Bhutange, (Age:21) was born in Chhindwara (Madhya Pradesh). He is pursuing B.E. degree in Electrical Engineering from Nagpur University, India.



Nikita N. Hadke, (Age:22) was born in Nagpur (Maharashtra). She is pursuing B.E. degree in Electrical Engineering from Nagpur University, India.



Aditi D. Kathane, (Age:21) was born in Nagpur (Maharashtra). She is pursuing B.E. degree in Electrical Engineering from Nagpur University, India