

IOT Based Home Automation Using Intel Galileo Gen-2

Bharati S. Kanherkar¹, Punam S. Pawar², Yogita R. Shende³,

Prof.Pradeep R. Taware⁴

^{1,2,3} Student, Electronics and Telecommunication, S.B.Patil College Of Engineering Vangali, Indapur
Maharashtra, India

⁴Assistant Professor, Electronics and Telecommunication, S.B.Patil College Of Engineering Vangali, Indapur
Maharashtra, India

Abstract - Now in days home security is so important. At 21st century human being become a part of automatic system. All human being turns to automatic system. In today's world Automatic systems are being preferred over manual system as rapidly increases of advance technology about home security and internet facilities human being are like so much. That's why we are taking this topic for work on the project. In our project is IOT based means internet of thing The Internet of things (IoT) is the inter-networking of physical devices means we can connect sensor, actuator, vehicle, software etc provide network connectivity of various devices and exchange data. internet of things is a growing network of everyday object-from industrial machine to consumer home appliances that can pass information and complete tasks while you are busy with other activities .Home Automation system(WHAS) using IoT is a system that uses computers or mobile devices to control basic home functions like (light, fan) and features automatically through internet from anywhere around the world, an automated home is sometimes called a smart home. In this paper we are present IOT based home automation using Intel Galileo-Gen2 .we made small (tiny) circuit for individual door, fan, light, window and connect to the Intel Galileo gen-2 board.

Key Words: (IOT, Intel Galileo Board Gen-2, LDR Sensor, Gas sensor, PIR Sensor, Temperature Sensor, Wi-Fi model)

1. INTRODUCTION

In this project we are using wireless technology for home automation. A home automation system is a means that allow users to control electric appliances of varying kind. The main aim of the project is to develop a system that will control of home appliances .the basic requirement or need is android app because of we are overall home appliances through android app. Home automation systems develop to automatically achieve some activities performed frequently in daily life to obtain more comfortable and

easier life environment. In home automation that can detect and identify you, automatically adjust the lighting to your predefined taste, open doors automatically, at night and switch them off in the morning, stream to you anywhere in the world via the internet. It is meant to save the electric power and human energy.IoT coverage is very wide and includes variety of objects like smart phones, tablets. Once all these devices are connected to each other, they enable more and more smart processes and services that support our basic needs.

In our project we are giving two facilities automatically operation and manually operation. We are operate home automation by automatically as well as manually it is totally depend on our choice. if some problem occurs in the automatically we can use manually.

1.1 Problem Statement

To built a Intel Galileo board Ethernet/Wi-Fi to control all the electric/electronic device connected to switches to provide more flexibility of doing thing and above securing homes or workspaces.

1.2 Literature Survey

SHome: A Smart Home Environment With Gen2. In this paper system can provide sensor data to android device and received data store in text file [1]. Internet Of Thing Based Home Appliances Control. In this paper IOT is used.IOT is a system that uses computers or mobile devices to control basic home functions and features automatically through Internet from anywhere around the world [2]. IOT Based Monitoring And Control System For home Automation. This paper based on raspberry-pi and IOT. In This paper describe an approach in which they are implement a controlling and continuous monitoring system to control various home appliances with Android smart phone [3]. Home Automation Using Internet Of Things. In this paper it is integration of cloud networking, wireless communication, to provide the user with remote control of various lights, fans, and appliances within their home and storing the data in the cloud [4]. IOT based smart home design using power and security management. In this paper the System to autonomous power control system in a user friendly and a mobile way

so that a user can manage the power management as well as security of their house. When not at the house itself, minimizing the power consumption [5].

2. BLOCK DIAGRAM

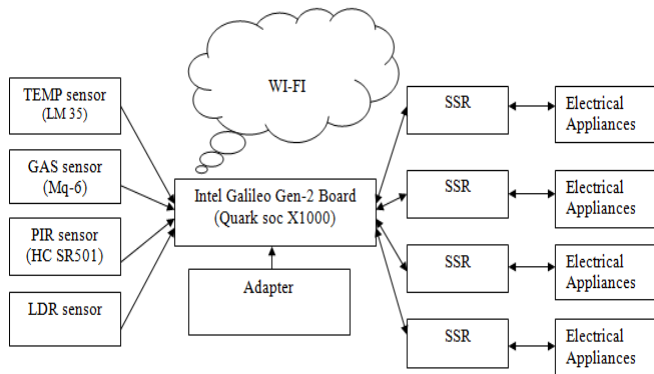

Fig: Block diagram

DESCRIPTION

In this project Intel Galileo gen-2 (soc quark x1000) board is main part. this board has total 20 pins out of this 6 pins are use for digital input /output pins and remaining 14 pins are use for analog input/ output pins. Operating frequency of Intel board is 400MHZ. suppose e.g. light is on before that LDR sensor sense intensity of light and then give message to the user that time user know light is on then user open home app in his mobile phone then press off key this action will goes to Intel Galileo through internet then Intel board receive message and read it then check light1, light2 etc then whatever relay is on which is communicate with Intel board that time relay will off & light also off. In the diagram we are taking electrical appliances such as fan, light, door, and window. In this project we use SSR devices. SSR stands for solid state relay. Solid state relay which is no moving .simply we can change firing angle and control the running device. We use electromagnetic relay but it is movable and cannot control device that why we use solid state relay. We take solid state relay as SCR because it latching device and current controlled device. The proposed model of the home automation system is as shown in the figure3.1. The model consists of different sensors like temperature, gas, motion and LDR. Initially the Intel Galileo connects to the internet through Wi-Fi. When the connection is established it will start reading the parameters of sensors like p1, p2, p3 etc. The threshold levels for the require sensors respectively are set as t1, t2, t3 etc. The sensor data are sent to the web server and stored in the cloud. The data can be analyzed anywhere any time. If the sensor parameters are higher than the threshold level then the respective alarm a1, a2, a3 etc. will be raised and the required actuation is done for the controlling of the parameters. In the proposed model the temperature, gas leakage, motion in the house is monitored. Similarly when there is a leakage of gas in the house that time board will

give message to the user . If we are in hurry sometime we will forget switch off light that time just open mobile app and see what condition in home simply press off/on button in app.

Intel board has many advantages compared to arduino board. The below table 1 shows the comparison between Arduino modules (Uno,Nano)and Galileo board.

Table -1: Comparison between Arduino Modules

Arduino Modules			
Arduino Type	UNO	Nano	Galileo
Digital I/O Pins	14	14	14
Processor	ATmega 328	ATmega 168	Intel
Memory Size	32 KB	32 KB	8Mbyte
Clock Speed	16MHZ	16MHZ	400MHZ

2.1 ARCHITECTURAL MODEL

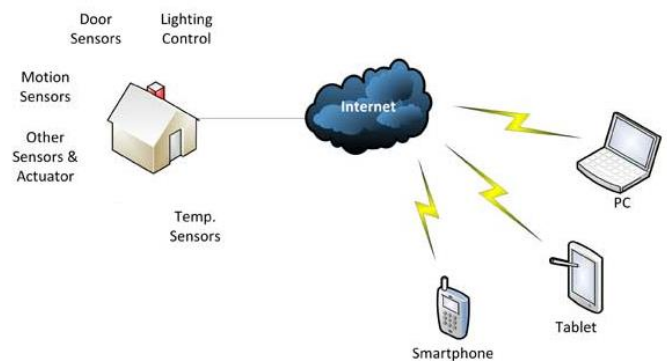

Fig: Architectural model

This is the architectural model of our project. Now sensor likes,

- Temperature Sensor- Show temp level in mobile App.
- Gas Sensor- Fire and Smoke Detection.
- PIR sensor- Motion Detection.
- LDR Sensor- Depend on Light Intensity.

This sensor sense data and give to Intel Galileo board. Then board Send the notification to the android app. The user can open app to firstly connect MQTT server then give the notification to the user whatever (connection is establish or connection is fail.)

If Connection is establish then access android app. If the connection is fail then not access android app then go return to server connectivity or wait for Wi-Fi availability.

All this description can be design in flow of operation.

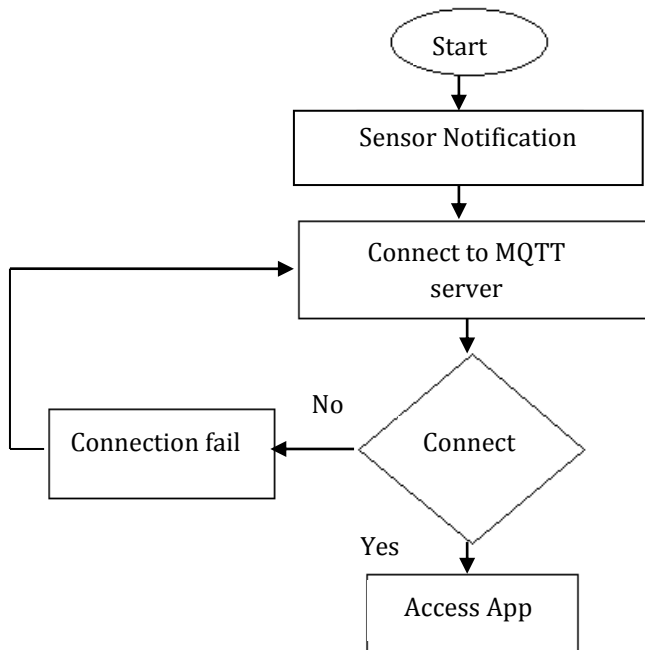

Fig -1: Flow of Operation

RESULT

The Home Automation System (HAS) is nothing but smart home. We are making small circuits for Example- such as for door, for window, for light (use LDR sensor), for kitchen (Using Gas Sensor), for Human entering or going out from home(using PIR Sensor) all these tiny circuit connected to the Intel Galileo Gen-2 board. And it is proven in the image.



3. CONCLUSIONS

The Home Automation using Internet Of Things has been proven to work satisfactorily by connecting simple appliances to it and the appliances were successfully controlled through internet. The designed system not only monitor the sensor data, like temperature, gas, light, motions sensor, but also

actuates a process according to the requirement for example- switching on the light when it gets dark.

4. FUTURE SCOPE

The project can be expanded to include various other options which could include home security feature like capturing the image of a person moving around the house. In future we can add also some voice alerts, SMS or alarm system. Then system can be expanded for energy monitoring, or weather stations. This kind of a system with respective changes can be implemented in the hospitals for disable or mentally disturb people or in industries where human invasion is impossible or dangerous, more critical and it can also be implemented for environmental monitoring.

REFERENCES

- [1] Dr. S.R.N. Reddy, Mr.Sumit K, Yadav Preeti Sharma "SHome: A Smart Home Environment With Gen2."
- [2] Pooja Patel, Mitesh Patel, Vishwa Panchal, Vinit Nirmal "Internet Of Thing Based Home Appliances Control."
- [3] Pavithra.D Ranjith Balakrishnan "Iot Based Monitoring And Control System For home Automation."
- [4] Vinay sagar K N Kusuma S M "Home Automation Using Internet Of Things."
- [5] Jasmeet Chhabra Punit Gupta "Iot Based Smart Home Design Using Power And Security Management."