

## Smart Helmet

Mr. Vivek A. Patel<sup>1</sup>, Mr. Akash Mishra<sup>2</sup>, Mr. Rana Hiten<sup>3</sup>, Mr. Kautik Prajapati<sup>4</sup>

<sup>1</sup>Assistant professor, electrical Engg, Mahavir Swami college of Engg. & Tec, Surat, Gujarat, India

<sup>2,3,4</sup>Student, electrical Engg., Mahavir Swami college of Engg. & Tec, Surat, Gujarat, India

\*\*\*

**Abstract** - Two-wheeler have high rate of accidents than cars or trucks and buses. The aim of smart helmet is to Provide Safety to the bike rider. With the help of Proper Switch Mounted in helmet the two-wheeler would not start without helmet so safety of rider is assured and if accident has occurred our system will give information to the ambulance about the accident, so they can take certain measures to save the life of the person who meet with an accident. It is developed using Arduino. We place sensors in different sides of helmet which is connected to Arduino board. So when the bike rider crashes sensors sense and the Arduino extract GPS location data using the GPS which is interfaced with Arduino. When the sensor data exceeds maximum limit of pressure then GSM module automatically sends message to ambulance, police and family members. In case of minor injuries, the rider can stop sending of message by the SMS sending stop switch.

**Key Words:** Accident prevention, Accident Reporting, Alcoholic driver detection, location tracking, Rider Detection

### 1. INTRODUCTION

#### 2.

Now-a-days, it is difficult to know that an accident has happened and to locate the position of the rider, there are many deaths occur due to lack of medical treatment.

The reasons for the accidents may vary such as no proper driving knowledge, no fitness of the helmet, rash driving, drink and drive etc. In some cases, the person injured due to lack of medical treatment in time or late arrival of ambulance, no person at place of accident to give information to the Ambulance. Our helmet ensures that the rider has wore the helmet and he/she has nonalcoholic breath and if accident has occurred it will inform the ambulance on time even there is no person to give information of the accident to the ambulance.

### 1.1 Objectives of Paper

- I. To design system that can improve bike rider safety.

- II. To design system reduces number of accident due to the drink and drive.
- III. To design system that ensure that the rider has wore the helmet
- IV. To design system that reduces the loss of life due to late arrival of the ambulance.

### 2. Working Principal

The aim of our smart helmet is to provide the safety to the bike rider and give information location of the accident to the ambulance and family member. This is done by using the GSM module. We are using SIM808 as the GSM module. But sending the message of that accident is not enough. We have to send the location of the accident. So we are using the SIM 808 as the GPS module it comes with the GNSS receiver. When the accident has happened the piezo-electric sensors sense the accident and give signal to the Arduino. Then Arduino will take location from the GPS and it will send the location of accident in the form of the latitude and longitude but normal user can't understand how get location from the latitude and longitude so we have implemented our system to send the google map link. Which will open in google maps and family members and the ambulance can take certain actions to save the bike rider life.

But we don't need to call ambulance every time sometimes the bike rider has minor injuries but piezo electric sensor will sense that as accident. In that case bike rider can stop sending of the SMS this is done by using the switch to stop accident. Before sending the accident message to the ambulance and family members the buzzer will ring for the 40 seconds if the bike rider has minor injuries he/she can stop the sending of the SMS simply by pressing the switch on helmet. If he/she won't press switch the SMS will be send to ambulance and family members.

Above system mentioned was for the accident reporting. Our system can also be used as accident prevention system. This is done by using the Alcoholic sensor and the Rider detection switch. Our system is designed to check the rider has worn helmet and he/she has non-alcoholic breath. If the both conditions are satisfied the Arduino will send signal to vehicle unit to start or stop vehicle via Bluetooth. The vehicle part contains the micro-controller and the relay to start or stop the ignition.

### 3. Block diagram

Our system can be divided into two parts first one is Helmet part and second Part is Bike part.

#### 3.1 Helmet Part

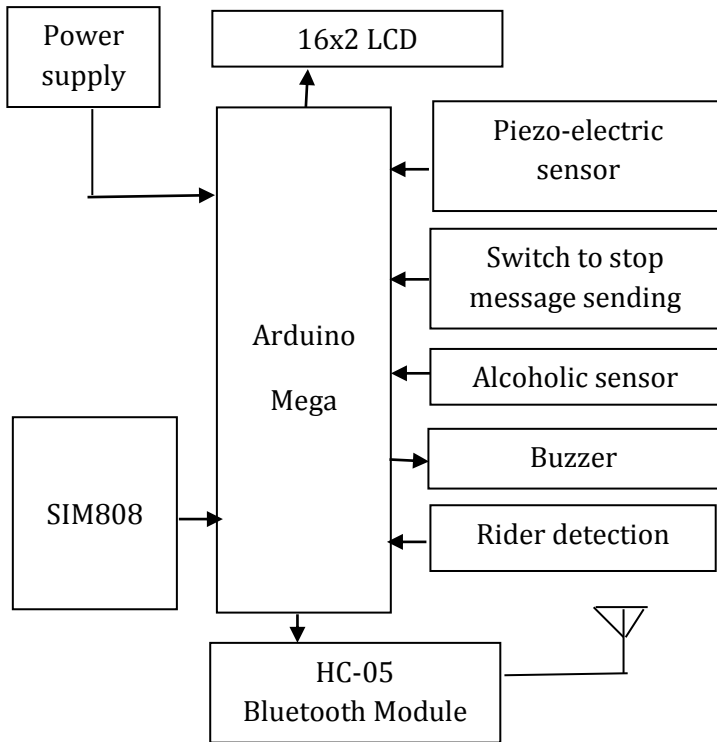

Figure -1: Block Diagram of Helmet Part

The block diagram of the helmet part is shown in above figure. The helmet part contains the Arduino mega as controller. SIM808 as the GSM/GPS module. 16x2 LCD for indication 16x2 LCD is optional. It contains the buzzer, piezo-electric sensor to sense the accident, alcoholic sensor, rider detection switch and switch to stop the message sending. And the HC-05 Bluetooth module which is configured in Master role. The power supply is given from the Lithium polymer battery.

#### 3.1 Bike Part

The block diagram of the bike part is shown in below figure. The bike part contains the Arduino Uno as controller. It contains HC-05 Bluetooth module which is configured in slave role. The power supply is given from the vehicle battery.

When it receives the signal from the helmet part via Bluetooth. This part starts or stop vehicle with help of the relay connected with Bike ignition.

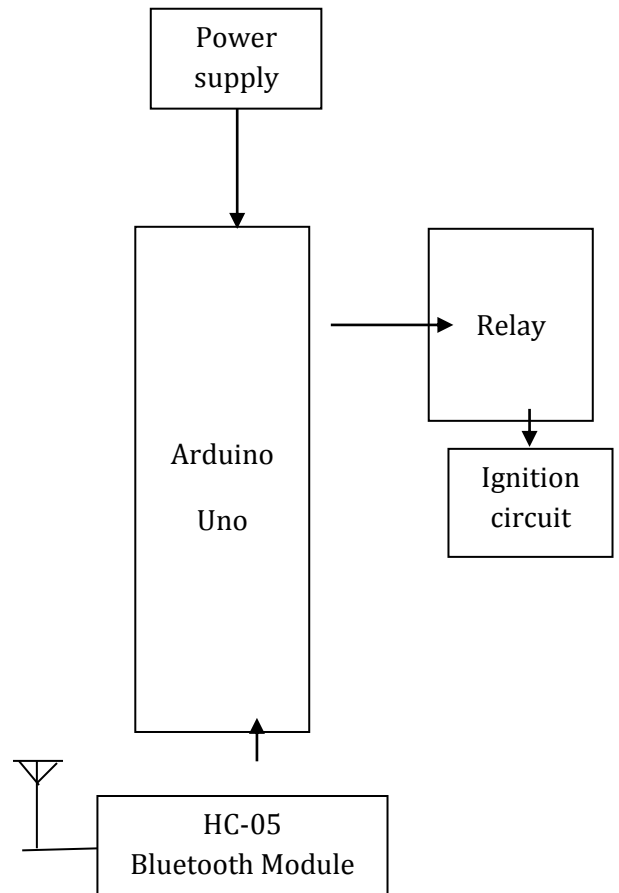

Figure -2: Block Diagram of Bike Part

### 4. Flow chart

The system is designed for the accident prevention and the accident reporting when needed.

The first step of the flowchart is it initializes Bluetooth communication between bike and helmet. Then it checks that rider has wear helmet or not, then it checks that driver is drunk or not, if the driver is not drunk and driver has were helmet it gives signal to the ignition system through relay then it will sense the value of the value of the piezo-electric sensor then it check for accident and if accident has occurred

The buzzer will ring for the 40 seconds after 40 second it will check the stop switch, if rider has pressed the stop switch in 40 seconds, it will go the one step above, else it will send the GPS location of the bike rider through the GSM module.

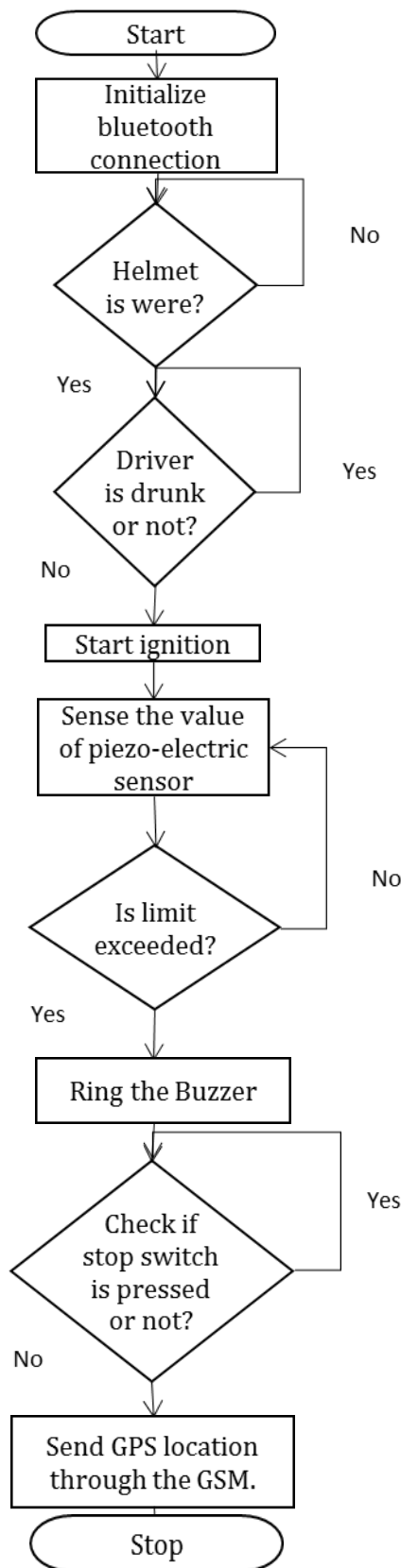

Figure -3: Flow chart of system

## 5. Applications and future scope

### 5.1 Applications

- I. it will useful for bike rider
- II. it will protect the Bike rider life.
- III. It will reduce the number of accident due to the drink and drive.
- IV. By wearing this helmet this helmet the rider will follow the basic rule of wearing helmet.

### 5.2 Future scope

- I. Solar plates can be used in helmet for the power - supply.
- II. It can be used for location tracking.
- III. GPRS can be used for the storing data online.
- IV. GPS can be programmed to calculate the speed of the bike in case of over speeding the vehicle can be stopped.

## 6. Result

Both the parts of system are tested the sensors are working perfectly. It takes the 8 seconds to take location from GPS and send through the GPS.

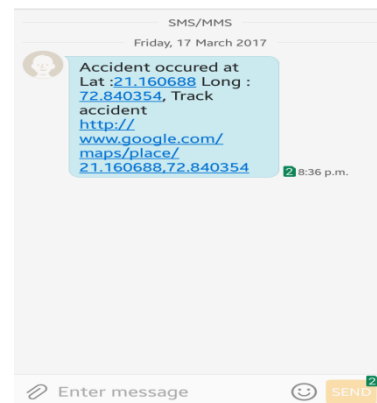

Figure -4: Message received

## 7. Conclusion

This helmet ensures the safety of the bike rider. A rider can't start bike if he drank alcohol or he/she hasn't were helmet, so he/she has to follow the traffic rules, and accident reporting feature will save the Bike rider's life.

## REFERENCES

- [1] Nitin Agarwal, , Anshul Kumar Singh , Pushpendra Pratap Singh , Rajesh Sahani. 2015. "SMART HELMET." *International Research Journal of Engineering and Technology (IRJET)* .
- [2] Prof. Chitte P.P., Mr. Salunke Akshay S. , Mr. Thorat Aniruddha N. Mr. Bhosale Nilesh T. 2016. "Smart Helmet & Intelligent Bike System." *International Research Journal of Engineering and Technology (IRJET)*.
- [3] Rajput, Prof. K. Y. 2016. "SMART HELMET." *International Research Journal of Engineering and Technology (IRJET)*.

## BIOGRAPHIES



Mr. Vivek Patel is a Assistant professor in MSCET Surat. He has 1.5 year of experience in Electical Engineering.



Mr. Akash Mishra is final year student in electrical department in MSCET, Surat.



Mr. Hiten Rana is final year student in electrical department in MSCET, Surat.



Mr. Kautik Prajapati is final year student in electrical department in MSCET, Surat.