

Night Vision Camera Technology Based Robot in War Field

Swapnil Mishra

SENSE Department, Vellore Institute Of Technology University, India

Abstract - With the purpose of the pleasant and meeting the converting needs of human from production unit to the household unit robotics and automation has been a wonderful key participant all through. This mission makes a specialty of constructing a RF primarily based spying robotic attached with wi-fi camera which can reduce the human sufferer. This robotic sends the sign to the base station the use of wireless camera. One of the predominant utility of this undertaking can be analyzed the use of android based totally smart cellphone which can be used to control the movement of the robotic. The robot sends the signal to the RF receiver established on the robot via RF transmitter at the base station. With this selection the robot can transmit real time motion pictures with night imaginative and prescient abilities and can not be identified by the enemies in conflict area.

Key Words: Wireless, robot, RF technology, robot, bluetooth, android.

1. INTRODUCTION

The purpose of developing a high-tech era that serves excessive pace era, superior capacity to govern the robots and to tool new methods of control theory. The realize above requirements a few technical development along side the need of excessive performance robotic is required to create a faster, dependable, accurate and extra smart robotic which can be devised by way of superior control algorithm, robot manipulate gadgets and new drivers. Earlier the robots were controlled via stressed out networks however now to make robotic extra customers pleasant, they may be framed to make person commanded paintings. Therefore to acquire the requirements we will use android as a multimedia to manipulate the consumer pleasant robotic.

The design of our task encourages developing a robotic car primarily based on RF generation for the far flung operation linked with the wi-fi camera installed on the robot for monitoring motive. The robotic is embedded with 8051 series microcontroller for desired operation and is normally used for spying functions. The transmitting module encompass the frenzy buttons that ship the commands to the receiving module for controlling the motion of robot either to right, left, forward, downward. In the receiving module of the robot cars are interfaced with the 8051 series of microcontroller to govern its movement thru motor driver IC. The far flung control (RF transmitter) has a variety of 200m that transmits the signals to the RF receiver. The receiver collects and decodes the received signals earlier

than feeding it to the microcontroller to force the DC cars through motor drivers. The wireless digital camera used for spying cause additionally serves in complete darkness the use of IR lightning (Shown in fig-1).



Fig -1: Design Robot with night vision camera

The wonderful programs of this idea in such robotic can be a clever smartphone controlled robots where the movement of the robot is controlled by way of a robotic on the premise of android platform. Smart smartphone transmits the AT instructions and information to the 8051 controller and controls the motor by using motor motive force L923D. The robotic motions left, proper, forward, backward. Interfacing is being carried out among tool and RF Module. RF module receives the commands from clever cellphone through 8051 microcontroller. Component technologies used are

- RF generation
- C language
- Embedded machine.

2. RF COMMUNICATION

RF frequency degrees from around three kHz to 300GHz .This corresponds to the frequency of radio waves and the alternating contemporary which carry radio sign. It refers back to the ac having such characteristics that if the modern-day is enter to an antenna an electromagnetic area is generated appropriate for wi-fi broadcast and verbal exchange. In order to get hold of radio signals an antenna ought to be used. This antenna will pick up lots of radio signal at a time and for the same we need to use a radio tuner to tune into a specific frequency. This is performed by means of using a resonator. Resonator amplifies oscillations inside a frequency band while decreasing the oscillations at other

frequency out of doors the band. Any RF area has a wavelength that's inversely proportional to the frequency. In the atmosphere, within the outer spaces, or anywhere in our atmosphere if frequency F is in MHz and the wavelength in meters, then $S=300/f$. The frequency of RF signal is inversely proportional to the wavelength of the EM discipline to which it corresponds. At 9 KHz, the free-space wavelength is approx. 33 kilometers or 21 miles (mi). At the highest radio frequencies, the EM wavelengths degree around one millimeter (1mm). As the frequency is accelerated past the RF spectrum, EM energy takes the shape of infrared (IR), seen, ultraviolet, X rays, and gamma rays.

3. Proposed System

Let us take a RF transmitter wiggling an electron in a single vicinity. This wiggling will electron reason a ripple impact, extremely same to dropping a pebble in a pond. The impact is an electromagnetic (EM) wave which travels out from the preliminary region those results in electrons to wiggle in far off locations. An RF receiver can discover the far off electron wiggling. The RF conversation gadget then similarly utilizes this phenomenon by way of wiggling electrons in a particular sample in an effort to constitute statistics. The receiver can make the identical information available at a faraway region by organising a verbal exchange without a wires. In most of the wi-fi structures a designer has overriding constraints: it have to perform over a sure distance (variety) and switch a certain quantity of information inside a time frame (data fee).

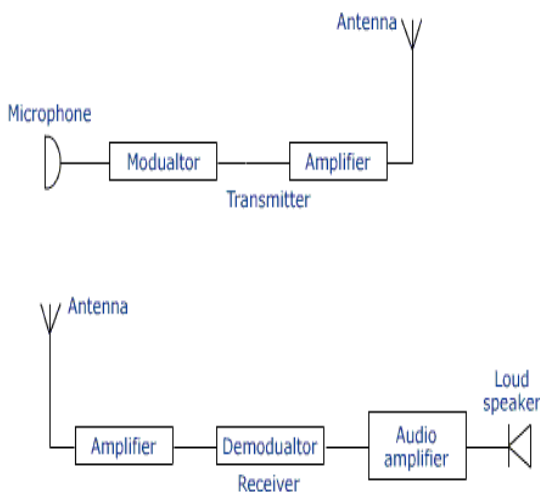

Fig -2: Block diagram for RF Module

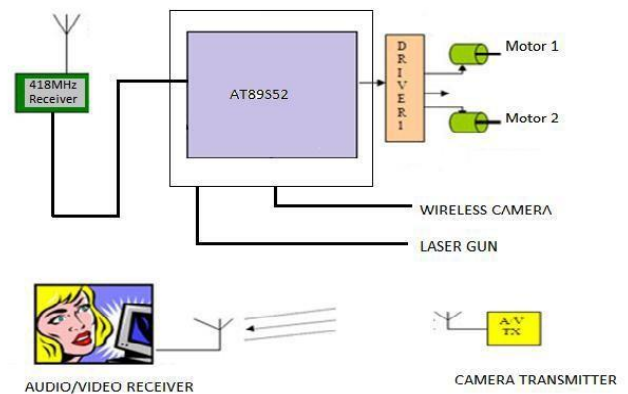

Fig -3: System Robot Block Diagram

The block diagram of the hardware implementation of the robotic is as proven inside the Fig-3. This robot is operated at radio frequency, self-powered and has all of the controls like a

regular automobile. Wireless digital camera is used to ship real time video and audio signals from the warfare area, which can be visible on a faraway monitor at the bottom station, and movement can be taken thus. Heart of this robotic is Atmel's AT89S52. Microcontroller is the grasp controller that decodes all the instructions obtained from the transmitter unit and give commands to slave microcontroller.

It also acts as Slave microcontroller on the receiver unit which is responsible for executing all the instructions acquired from the master and additionally generates PWM pulses for the speed manage of the robotic. Based on the enter codes given through the user grasp will deliver command to slave microcontroller and robotic will behave as follows.

- movements from side to side
- turns left or right at the same time as moving forward or backward
- Controls speed in both the direction.

Transmitter Unit:

For modulating the frequency variable frequency oscillator 1 is used i.E. To be transmitted and output is received a high frequency oscillator for generating a service wave. Antenna radiates carrier wave into area.

Receiver Unit :

The receiving antenna for detecting the waves transmitted with the aid of transmitter antenna is connected to a tuned wave detecting circuit. The tuned wave detecting circuit's output is hooked up to amplifier which in turn has its output linked to the enter of the low skip frequency in addition to the filter out to a excessive skip frequency clear out.

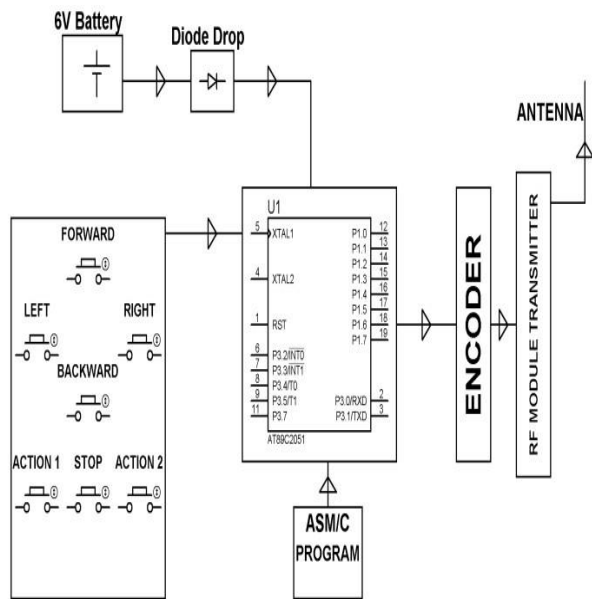

Fig -4: Transmitter Unit Block Diagram

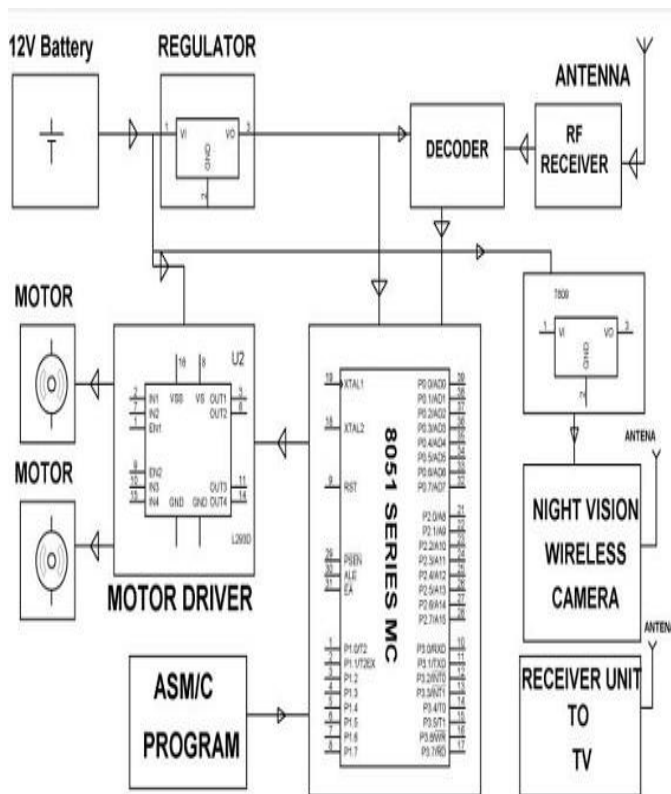

Fig -5: Receiver Unit Block Diagram

The amplifiers outputs are linked to split cars and different facet of cars are related to voltage potential .The excessive frequency is extracted from the excessive bypass frequency filter and coffee frequency is extracted from low bypass frequency clear out.

Microcontroller Circuit (AT89S52) :

It is the heart of the system as it controls all of the sports of transmitting and receiving. AT89S52 IC is used. The AT89S52 Microcontroller is an 8-bit microcontroller of 8051 series with 8K Bytes of In-System Programming Flash Memory. Atmel’s high-density nonvolatile reminiscence generation is used for production of the device and is like minded with the enterprise general 80C51 coaching sets. The on-chip Flash reminiscence allows this system memory to be reprogrammed in-system or a traditional nonvolatile reminiscence programmer is used [3]. Atmel AT89S52 is a powerful microcontroller by means of combining a versatile 8-bit CPU with in-gadget programmable Flash on a monolithic chip, it gives a fee-effective and rather-bendy approach to many embedded control packages. The Idle Mode is used to prevent the CPU even as permitting the RAM, serial ports, timer/counters, and interrupt system to continue functioning.

5. RESULTS AND TESTING

The entire manage of the robot is done remotely. It includes a transmitter section which transmits the required information to the receiver segment. The Robot is clearly protected by way of urgent few buttons at the transmitter side. The transmitter unit includes an encoder which receives parallel information input from the microcontroller through the frenzy buttons and transmits this parallel statistics in serial layout through the RF module. On pressing the respective push button (fig-6 shown Remote control), Microcontroller is programmed to send relevant indicators to the Encoder in parallel shape. The encoder converts those parallel indicators to serial shape to be transmitted by the RF module. This serial information is modulated with a service signal the use of a RF transmitter and is transmitter. For instance if we press the left button, the microcontroller sends the command to the receiver unit via the encoder and the RF module.



Fig -6: RF Remote control

The statistics right here is essentially a binary collection. Here we use a 4-bit gadget. The four bits records are managed by the four switches. The transmitter phase will consist of the switches (permits binary sequence) and HT12E encoder that encodes the parallel data to serial records. Now this serial records is transmitted over 434Mhz

provider channel the use of ASK modulation through a brief dipole antenna. Table-1 shows the controlling of Robot.

Table -1: Sample Table format

Button Pressed	Motor Movement
Forward-Button	Accelerate Forward
Backward-Button	Accelerate back
Left-Button	Turn Left
Right-Button	Turn Right

The receiver section consist RF receiver which gets the serial statistics on same carrier frequency and HT12D decodes the serial to the parallel records (as to begin with became on the transmitter). This 4 bit facts obtained will pressure the motor driving force and the motive force in turn will force the motors of the ROVER to carry out the operations.

5. CONCLUSIONS

The primary need for our paper would be accuracy. We have been capable of view the things correctly which can be presently happening in the surrounding region. Our layout has no longer caused any sort of disturbances. The robot will circulate depending at the motor direction based totally upon the enter we provide thru command via remote phase unit. It show the current operation is going on as instance left robotic, near to item, solve. With the help of the digicam we're capable of view the matters that are happening in the surrounding areawhere the robotic is hidden. By maintaining the circuit smooth and easy, most users may be capable of use it without difficulty. Thus we need to be able to control its course while vital, to create the robot thoroughly. To all that, a control unit is wanted, in which manage devices RF signal is used. By the usage of those alerts encoding is achieved & sign is despatched thru the transmitter. At the receiver end these decoded signal are given as input to drive the motor. Not for lengthy range programs it is able to be used as a spy robot within quick distances.

REFERENCES

- [1] Selvam, M. "Smart phone based robotic control for surveillance applications."Dept. of ECE, Karpagam University, Coimbatore, Tamil Nadu, International Journal of Research in Engineering and Technology (2014).
- [2] Jenifer, T. Maria, et al. "Mobile Robot Temperature Monitoring System Controlled by Android Application via Bluetooth." International Journal on Advanced Computer Theory and Engineering (IJACTE) 2.3 (2013).

- [3] Pahuja, Ritika, and Narender Kumar. "Android Mobile Phone Controlled Bluetooth Robot Using 8051 Microcontroller." Electronics & Communication Engineering, Department, BRCM College of Engineering & Technology, Bahal, India, International Journal of Scientific Engineering and Research (IJSER) www.ijser.in ISSN (Online) (2014): 2347-3878.
- [4] Mehta, Mr Lokesh, and Mr Pawan Sharma. "SPY Night Vision Robot with Moving Wireless Video Camera & Ultrasonic Sensor." Yeole, Aniket R., et al. "Smart Phone Controlled Robot Using ATMEGA328 Microcontroller."
- [5] Borker, Kunal,Rohan Gaikwad, and Ajaysingh Rajput. "Wireless Controlled Surveillance Robot." International Journal 2.2 (2014).
- [6] MacMillan, Neil, et al. "Range-based navigation system for a mobile robot."Computer and Robot Vision (CRV), 2011 Canadian Conference on. IEEE, 2011.