

POWER LINE CARRIER COMMUNICATION BASED LOAD SCHEDULING

Aravind Chitharanjan¹, Sarath C M², Dheeraj E M³, Ninu Joy⁴

^{1,2,3}Student, Dept. Electrical and Electronics, Mar Athanasius College Of Engineering, Kerala, India

⁴ Assistant professor, Dept. Electrical and Electronics, Mar Athanasius College Of Engineering, Kerala, India

Abstract - Power line carrier communication (PLCC) carries data on a conductor that is also used simultaneously for AC electric power transmission or electric power distribution to consumers. This MCU based project is to control the load shedding on the basis of current consumption of a customer. A current sensor in consumer end monitors load current. In substation end a limit value of current that entered through keypad is transmitted through modem. The modem at the consumer end demodulates the data and gives it to the MCU. If current goes above limit value then the MCU operate relay to switch off the load. Operation of the system is set for peak time of 6.30 pm to 10.30 pm and RTC is used to set time. By this current monitored individual load scheduling system we can efficiently reduce unnecessary load shedding for long hours in an area.

Key Words: Plc communication, Substation, Plc modem, Consumer, Current sensor, Current consumption, Peak time, Regulation

1. INTRODUCTION

Power line carrier communication (PLCC) carries data on a conductor that is also used simultaneously for AC electric power transmission or electric power distribution to consumers. It is also known as power line carrier, power line digital subscriber line (PDSL), mains communication, power line telecom (PLT), power line networking (PLN), and broadband over power lines (BPL)[2].

A wide range of power line communication technologies are needed for different applications, ranging from home automation to Internet access. Electrical power is transmitted over long distances using high voltage transmission lines, distributed over medium voltages, and used inside buildings at lower voltages. Most PLCC technologies limit themselves to one set of wires (such as premises wiring within a single building), but some can cross between two levels (for example, both the distribution network and premises wiring).[1] Typically transformers prevent propagating the signal, which requires multiple technologies to form very large networks. Various data rates and frequencies are used in different situations.

1.1 Power Line Carrier Communication

Power line communications systems operate by impressing a modulated carrier signal on the wiring system. Different types of power line communications use different frequency

bands, depending on the signal transmission characteristics of the power wiring used. Since the power distribution system was originally intended for transmission of AC power at typical frequencies of 50 or 60Hz, power wire circuits have only a limited ability to carry higher frequencies. The propagation problem is a limiting factor for each type of power line[3] communications. Data and distance limits vary widely over many power line communication standards. Low-frequency (about 100–200 kHz) carriers impressed on high-voltage transmission lines may carry one or two analog voice circuits, or telemetry and control circuits with an equivalent data rate of a few hundred bits per second; however, these circuits may be many miles long. Higher data rates generally imply shorter ranges; a local area network operating at millions of bits per second may only cover one floor of an office building, but eliminates the need for installation of dedicated network cabling.[1]

2. WORKING

This PLC based load scheduling system is used to control the load shedding on the basis of current consumption of customers on peak hours through PLC modem.

2.1 Transmitter Section

Transmitter section has keypad, microcontroller, PLC modem, LCD displays and audio & visual indications. With the help of this keypad we can select a limit value for current for each device. This limit values for each device are transmitted to the receiver side through power line modem. The data entered is modulated and transferred through 230 V power lines along with AC signals.

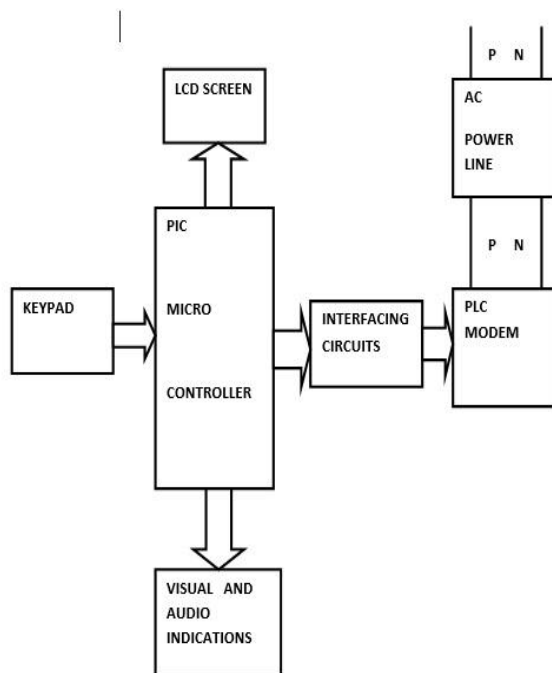

Fig -1: Substation end

The plc Modem transmits the limiting value of current through the AC power lines along with the power

2.2 Receiver Section

Receiver side includes power line modem, current sensors, microcontroller, relays & relay interfacing. Power line modem is attached with a microcontroller through an interface circuit. MCU receives the transmitted details through the power line modem and displays it on the LCD.

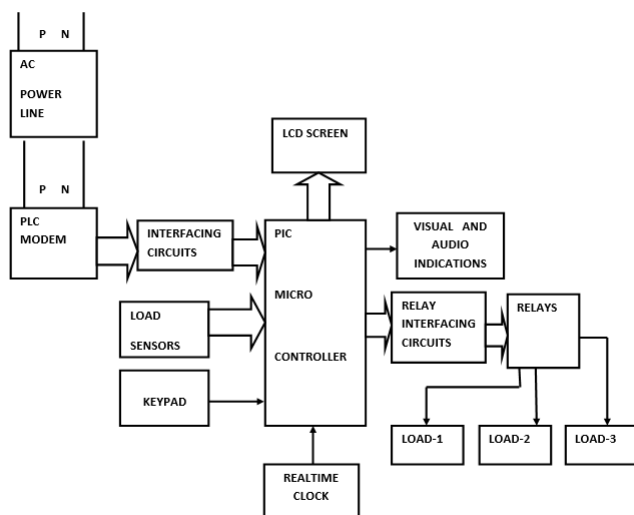

Fig -1: Consumer end

A current sensor is placed in the consumer end to monitor load current. The modem at this end demodulates the data and gives it to the MCU. From current sensor output

interfaced with the MCU, it determines the amount of current flowing. MCU compares the current sensor output with the limit value received. If current goes above limit value then the microcontroller operate the corresponding relay to OFF the devices. A relay interface is used here because the current output from the microcontroller is very small that it is not sufficient to magnetize the relay. After a particular time interval relay operate to switch on load. If the load current remains above limit then load switch off again. Operation of the system is set for peak time of 6.30 pm to 10.30 pm and RTC is used to set time. An LCD unit is used to display status of the system and time information. LEDs will be ON when devices are ON and in OFF condition during devices are in OFF condition.

3. CONCLUSIONS

This MCU based project 'PLCC controlled load scheduling' is developed to control the load shedding on the basis of current consumption of each consumer. PLC modem is used for communication between substation and consumer. Power line modem is useful to send and receive serial data over existing AC mains power lines of the building. It has high immunity to electrical noise persistence in the power line and built in error checking so it never gives out corrupt data. A current sensor in consumer end monitors load current. In substation end a limit value of current that entered through keypad is transmitted through PLC modem. The modem at the consumer end demodulates the data and gives it to the MCU. If current goes above limit value then the MCU operate relay to switch the load off. Operation of the system is set for peak time of 6.30 pm to 10.30 pm and RTC is used to set time. By this current monitored individual load scheduling system we can efficiently reduces unnecessary load shedding for long hours in an area.

REFERENCES

- [1] Young-Sung Son, Topi Pulkkinen, Kyeong-Deok Moon and Chaekyu Kim, "Home Energy Management System based on Power Line Communication", IEEE Transactions on Consumer Electronics, Vol. 56, No. 3, August 2010
- [2] Subhra J. Sarkar, Palash K. Kundu, "A Proposed Method of Load Scheduling And Generation Control Using GSM And PLCC Technology", MFIIS, Paper ID.176, september 2015
- [3] M V Aleyas, Nishin Antony, Sandeep T, Sudheesh Kumar M, Vishnu Balakrishnan, "Automatic Meter Reading and Load Management Using Power Line Carrier Communication ", IJAREEIE ,Vol. 3, Issue 5, May 2014