

DESIGN OF PRESSURE VESSEL USED IN PACKAGE DYEING SYSTEM

Naval Yemul¹, Dr. P.R.Kulkarni²

¹Dept. of Mechanical Engineering, Walchand Institute of Technology, Solapur.

² Professor, Dept. of Mechanical Engineering, Walchand Institute of Technology, Solapur.

Abstract - Pressure vessel is the heart of the package dyeing system used in textile industries. This paper presents design of pressure vessel used in dyeing system. In the design of pressure vessel safety is the prime importance, due the potential impact of possible accidents. Efforts are made to design the pressure vessel using ASME codes & standards to legalise the design. The 3 dimensional models of various parts of the package dyeing system have been designed for safe operation and a small capacity (5kg) package dyeing system has been developed.

Key Words: ASME codes, Package Dyeing System, Pressure Vessel, Yarn

1. INTRODUCTION

The textile industry holds significant status in the India. Textile industry provides one of the most fundamental necessities of the people. It is the second largest employment generator after agriculture [1]. About 35 million people are already engaged with this sector [2]. The textile sector comprises clothing, apparel, garments, chaddars and bed-sheets, terry towels and allied products. Solapur is known for its textile products. It has a good base for its industries for logistical reasons, with approximately 98 medium and 8986 smaller industries [1]. In any textile product quality mainly depends on color. And colors have some importance in Indian tradition. Dyeing yarn adds beauty to textile products. Now a day's dyeing has become a most integral part of textile process. Figure 1 shows the Flow diagram of dyeing process in textile processing

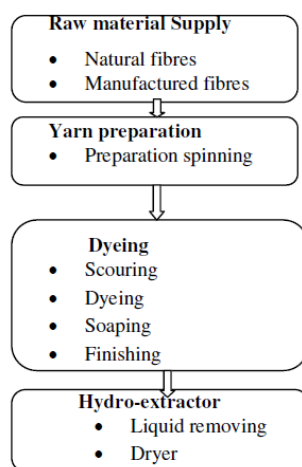

Figure 1: Schematic flow diagram for dyeing of textile processing.

1.1 Dyeing

Dyeing is a method which imparts **beauty** to the textile by applying various colors and their shades on to a fabric. Dyeing can be done at any stage of the manufacturing of textile fiber, yarn, fabric finished textile product including garments and apparels.

1.2 Package Dyeing Process

The term package dyeing usually denotes for dyeing of any type yarn wound on the compressible dye springs/perforated solid dyeing tubes or cones [3]. Yarn dyeing in package form is done at under high pressure, with the packages mounted on hollow spindles.

2. LITERATURE REVIEW

The literature has been carried out on pressure vessel and pump used in package dyeing system. The detailed study of design and analysis of pressure vessel are studied. The design of pressure vessel is governed by the American Society of Mechanical Engineers (ASME) pressure vessel codes Section VIII Division 1

Tsui Tak Ming William [5] had invented the Sample package dyeing machine shown in figure 2. A dyeing machine used for dyeing a sample yarn package comprises a kier, a spindle mounted in the kier for supporting a sample yarn package, and a dye liquor circulation system operable to circulate dye liquor through the sample yarn package with inside-to-out and outside-to-in flow directions, the kier and the spindle configured to accommodate a single sample yarn package with a weight less than 1.2 kg,

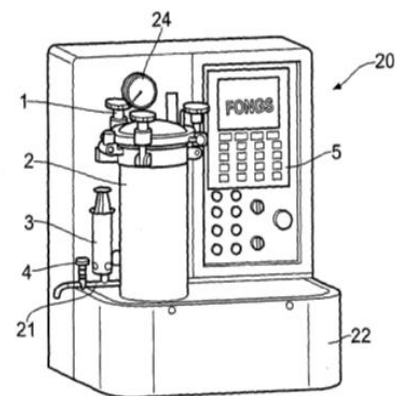

Figure 2: Sample Package dyeing machine.

Amar A. Bhojar and Shrikant M. Fulmali [6] efforts have been made to Design and Fabricate the automatic cloth dyeing machine and described Dyeing has a method of which enhances beauty to textile by applying various colours and their shades on to a fabric. The purpose of this research is to design, develop and evaluate automatic cloth dyeing machine. Figure 3 shows model of cloth dyeing machine.

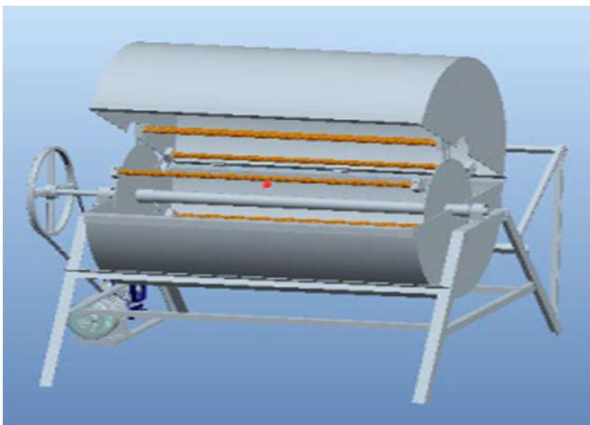

Figure 3: Front view of Cloth Dyeing Machine

Tsui, Tak Ming William and Clifford, Frank Graham [7] their invention relates to a pump incorporated in a textile package dyeing machine. According to the invention there is provided a pump comprising an axial flow impeller rotating in a concentric cylindrical housing to pump treatment liquor through the machine, the pump having an axial nozzle at one end and centrifugal nozzle at the other end whereby a flow and pressure performance characteristic typical for a centrifugal pump can be obtained when the impeller is rotated in one direction and a flow and pressure performance typical for an axial flow pump can be obtained when the impeller is rotated in the opposite direction. B.S.Thakkar and S.A.Thakkar [8] did a case study and put efforts to design the pressure vessel using ASME codes & standards to legalize the design. The performance of a pressure vessel under pressure can be determined by conducting a series of tests to the relevant ASME standard in future scope they have mentioned Design of pressure vessel in PVELITE software can be accrue.

Ahmed Ibrahim et al [10] presented their work on detailed stress analysis and stressed developed in thin walled pressure vessel. Equations of static equilibrium along with the free body diagram has be used to determine the normal stressed σ_1 in the circumferential or hoop direction and σ_2 in the longitudinal or axial direction.

Shyam R Gupta and Chetan P. Vora [11] had presented work on a review on pressure vessel design and analysis, this paper deals with developments in the determination of

stress concentration factor in pressure vessels at opening, stress analysis of different types of end connections.

2.1. OBJECTIVES OF THE WORK

- To design a small capacity (5 kg) package dyeing system for textile industries.

3. DESIGN METHODOLOGY

The pressure vessel designed in accordance with the ASME Code, Section VIII - Division 1. The American Society of Mechanical Engineers (ASME) Section VIII, rules for fired or unfired pressure vessels, is divided into three divisions to provide requirements applicable to the design, fabrication, inspection, testing, and certification.

3.1 Material Selection

Material Assigned for pressure vessel shell, head, nozzle, inlet and outlet are of stainless steel 316 grades and for leg supports are stainless steel 304 grades.

3.2 Design of cylinder shell for internal pressure.

Design of a vertical thin shell pressure vessel according to ASME code Section VIII Division 1 for the following input data:

| Notation and Description | Value | Unit |
|------------------------------------|-------|--------------------|
| P = Internal Pressure | 5 | kg/cm ² |
| D = Inside Diameter | 500 | mm |
| T = Inside Temperature | 120 | °C |
| L = Length | 600 | mm |
| E = Weld Efficiency of the seam | 0.85 | |
| Corrosion Allowance | 1 | mm |
| σ_t = Tensile Stress | 515 | MPa |
| FOS | 3 | |
| S = Allowable or Calculated Stress | 172 | MPa |
| t_{shell} = Assumed Thickness | 3 | mm |

Table 1: Input data for design of shell.

Allowable stress is calculated by

$$S = \frac{\sigma_t}{FOS} = \frac{515}{3} = 171.6 \approx 172 \text{ MPa}$$

3.2 Calculating the thickness of cylindrical shell

Criteria for thin wall pressure vessel is $\frac{t}{D} < 0.1$

Hence, the ratio is less than 0.1 we can conclude that the pressure vessel is thin. The formulae in ASME Section VIII,

Division 1, and paragraph UG-27, used for calculating the minimum wall thickness of pressure vessels, is given below:

- a. Minimum required thickness at the longitudinal welds (Circumferential Stress)

when $P < 0.385SE$

$$t_l = \frac{P \times R_i}{(S \times E - 0.6 \times P)}$$

$$t_l = 0.84 \text{ mm}$$

- b. Minimum required thickness at the circumferential welds (Longitudinal Stress)

when $P < 1.25SE$

$$t_c = \frac{P \times R_i}{(2 \times S \times E + 0.4 \times P)}$$

$$t_c = 0.42 \text{ mm}$$

Required Thickness $t_r = t_{max} + C$

$$t_r = 0.84 + 1$$

$$t_r = 1.84 \text{ mm}$$

For the pressure vessel design minimum thickness required is (1.84 mm) so assumed thickness (3 mm) is safe for application as shown in figure 4.

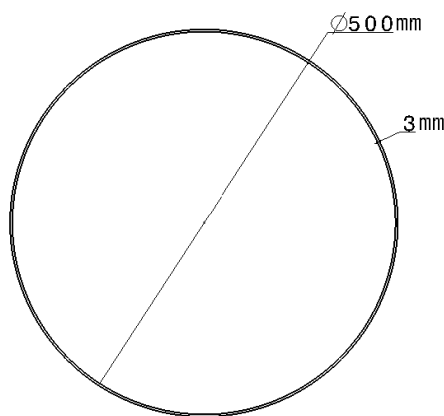

Figure 4: Thickness of cylindrical shell

3.3 Pressure Calculation inside the cylindrical Shell

The pressure use in the design of a vessel is called design pressure. Design of vessel and its parts for a higher pressure than the operating pressure by using ASME code is given below:

- a. Longitudinal pressure applied to the pressure vessel

$$P_l = \frac{(S \times E \times nt)}{(R_i + 0.6 \times nt)}$$

where nt = Nominal thickness

= Actual thickness – corrosion allowance

$$P_l = 1.164 \text{ MPa}$$

- b. Circular pressure applied to the pressure vessel

$$P_c = \frac{(2 \times S \times E \times nt)}{(R_i - 0.4 \times nt)}$$

$$P_c = 2.34 \text{ MPa}$$

The ASME code says that max allowable pressure inside the vessel, P_m is given by

$$P_m = \text{Minimum of } P_{(l, c)}$$

$$P_m = P_l = 1.164 \text{ MPa}$$

Actual working pressure inside vessel is less than maximum allowable pressure hence, design is safe. Figure 5 shows the pressure acting inside the cylindrical shell.

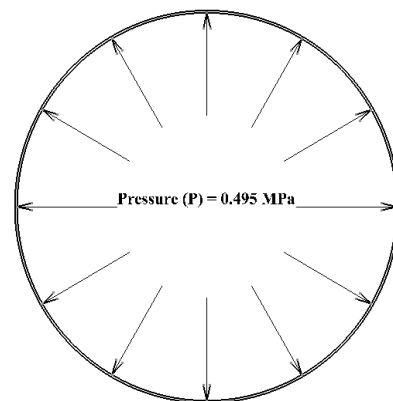

Figure 5: Pressure acting inside the shell

3.4 Calculating Maximum Allowable Working Pressure (MAWP)

The MAWP for a vessel is maximum permissible pressure at the top of the vessel in its normal operating position at a specific temp usually design temperature. When calculated the MAWP should be stamped on the nameplate. The formulae used for calculating the Maximum Allowable Working Pressure by ASME codes, is given below:

$$MAWP = P_w = S \times \frac{(2 \times t - 0.01 \times D - 2e)}{D - (t - 0.005 \times D - e)}$$

$$P_w = 1.035 \text{ Mpa}$$



Figure 6 : Bottom Head

3.5 Calculating Nozzle Thickness

In Pressure vessels openings are required for inlet and outlet purposes. Openings in cylinder vessel may be preferably circular, elliptical or obround.

According to ASME code, the minimum wall thickness required of piping under pressure is given below:

$$t_{nozzle} = t_n = \frac{PR}{(SE - 0.6P)} + C$$

$$t_n = 1.13 \text{ mm}$$

Minimum thickness required for nozzle is $t_n = 1.13\text{mm}$

3.6 Calculation for Semi Ellipsoid head and bottom of the pressure vessel

The minimum required thickness and maximum allowed pressure calculation of the top and bottom of semi ellipsoid shell portion of the thin walled pressure vessel according to the ASME code. Minimum required thickness for semi ellipsoid head and bottom portion of the pressure vessel is given below:

$$t_{min} = \frac{PD}{(2SE - 0.2P)} \quad \dots\dots I$$

$$t_{min} = 0.843 \text{ mm}$$

Maximum Allowed Pressure for semi ellipsoid head and bottom is given below:

$$P_{min} = \frac{(2SE - 0.2P)}{(R - 0.4nt)} \quad \dots\dots II$$

$$P_{min} = 2.34 \text{ MPa}$$

The ASME codes suggests that for the thin wall pressure vessel design is safe if

1. Actual shell thickness at the semi ellipsoidal portions $t \geq t_{min}$
2. $P < P_{min}$

From the Eq. I,

As, t_{min} (0.843mm) is much lesser than the actual thickness (3 mm) for this pressure vessel design, so

the design is acceptable according to the ASME design codes.

From the Eq. II,

As, P_{min} (2.34 MPa) is larger than P (0.4905 MPa) so the pressure vessel design is safe according to the ASME codes. Figure 6 shows the 2D drawing of bottom head with 3mm thickness.

3.7 Design of carrier

The calculations for small capacity package dyeing pressure vessel are made by taking consideration of yarn dyeing bobbin.

Yarn Dyeing Bobbin

The yarn dyeing bobbin plays an important part in package dyeing system. The Yarn (cotton or polyester) is wounded on this bobbin. The bobbin is then placed on the chesses (spindles) carried where the carriers are loaded for dyeing.

The figure 7 shows the yarn dyeing bobbin with holes.

- i. Diameter of the bobbin is 65 mm
- ii. Height of the bobbin is 165mm
- iii. Diameter of the cone when yarn is wound on bobbin is 197mm



Figure 7: Plastic Yarn Dyeing Bobbin

3.7.1 Calculation for capacity of the package dyeing system:

The calculations for small capacity package dyeing pressure vessel is made by taking consideration of yarn dyeing bobbin

- i. 1 cone yarn is made up of 1 to 1.1 kg or 1000 to 1100 gms.
- ii. 3 spindles are used in dyeing vessel
- iii. 2 cone yarn are placed on each spindle

- iv. $3 \times 2 = 6$ cone yarns in the vessel
 - v. 6 cone yarn \times 1 to 1.1 kg per yarn = 6 kg capacity.
- Figure 5 shows the top view of carrier with 3 spindles of 65mm diameter.

The capacity of the system can be calculated as per the customer's requirement it mainly depends on yarn dyeing bobbin dimensions. Figure 8 shows the top view of carrier with 3 perforated spindles.

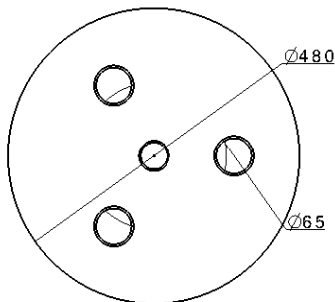

Figure 8 : Top view of carrier

3.7.2 Height of the spindle in carrier:

Height of spindle is calculated by taking the yarn bobbin dimensions, height of each bobbin is 165mm. Figure 9 shows the 2D drawing of the carrier with height and diameter of the spindle

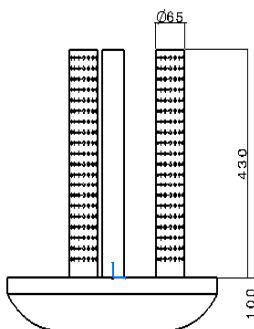

Figure 9 : 2D drawing of the carrier with height and diameter of the spindle.

3.7.3 Diameter of the carrier:

The Diameter of the carrier is calculated as 480mm. The diameter of bobbin when yarn is wound on it is 197mm. Figure 10 shows the top view of carrier with yarns placed on spindles.

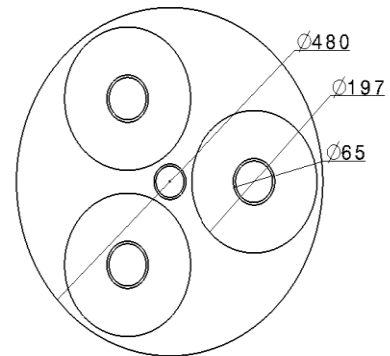

Figure 10: Top view of carrier with yarn

3.8 Three dimensional modeling

The various parts of the package dyeing system like cylindrical shell, semi elliptical head and carrier has been developed in CATIA software.

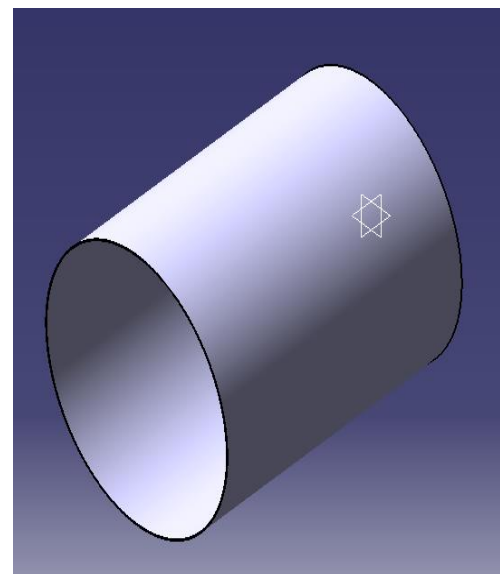

Figure 11: Cylindrical shell

Figure 11 shows cylindrical shell with thickness 3mm, diameter 500mm and length 600mm.

The CATIA model of the carrier with three perforated spindles which are equidistance with 120° is shown in the figure 12. The diameter of the carrier is 480mm. The length of the perforated spindles is 430mm

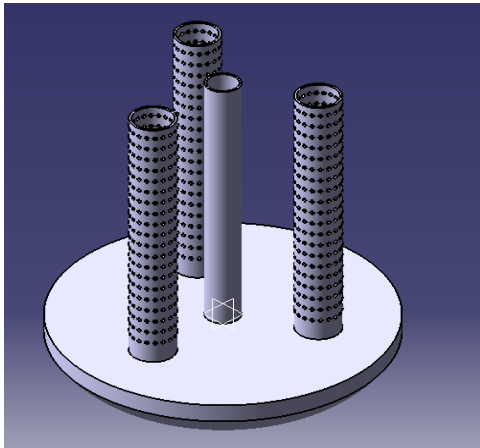

Figure 12: Carrier

Figure 13 shows semi elliptical bottom head with 3 leg supports and 4 openings.

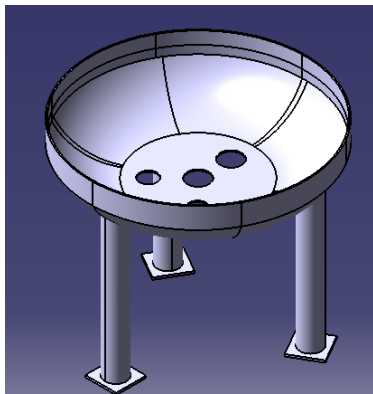

Figure 13 : Leg Support

The assembled 3D model of the package dyeing system with semi elliptical head, cylindrical shell, and carrier is shown in figure 14. with 6 kg capacity

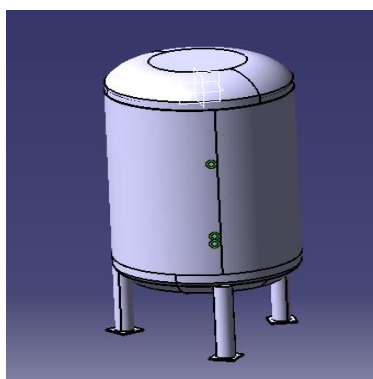

Figure 14: Assembled 3D model of Pressure vessel system

4. CONCLUSION

Pressure vessel of (5 kg) used in package dyeing system is designed and checked according to the ASME codes and found safe. From the design calculation it is observed that maximum allowable pressure (1.035MPa) is within permissible range (0.495MPa). The required thickness (1.84mm) of cylindrical shell and head are well below the assumed thickness (3 mm).

REFERENCES

- [1] Tanaji Dabade, Dr. Shivaji Gawade and Prof. Balaji Khune "Solapur textile industry an overview on marketing and financial problems" Zenith International Journal of Multidisciplinary Research Volume.2 Issue 5, ISSN 2231 5780, May 2012
- [2] P.R.Kulkarni, S.P.Kallulkar, "Improvement In Dyeing Process Parameters – A Case Study Of Solapur Based Textile SME", Avishkar – Solapur University Research Journal, Vol. 3, 2014
- [3] Kuldip A Rade, V.A. Pharande and D.R. Saini "Energy optimization in Dyeing Process by Using Controlled parameters" International Journal of Innovative Research in Science, Engineering and Technology Vol. 3, Issue 6, ISSN: 2319-8753, June 2014
- [4] Md. Tanjin Amin, "Overview of a Knit-Dyeing Factory with Necessary Production Formulas" Global Journal of Researches in Engineering: G Industrial Engineering Volume 14, Issue 1, Version 1.0, and 2014
- [5] Tsui Tak Ming William, "Sample package dyeing machine" European Patent Application, Patent no EP 1990455A1, November 12th, 2008
- [6] Amar A. Bhojar, Shrikant M. Fulmali, "Design and Experimentation of Automatic Cloth Dyeing Machine", International Journal for Research in Applied Science and Engineering Technology, Volume 4 Issue III, March 2016.
- [7] Tsui, William Tak Ming and Clifford, Frank Graham "A pump incorporated in a textile package dyeing machine" European Patent Application, Patent no EP 0816547 A1, January 7th, 1998
- [8] B.S. Thakkar and S.A. Thakkar "Design of pressure vessel using ASME code, SECTION VIII, DIVISION 1" International Journal of Advanced Engineering Research and Studies, Volume 1, Issue 2, E-ISSN2249-8974, March 2012

- [9] MR Shamey and JH Nobbs "A review of automation and computer control in dyeing machinery" *Advances in colour science and technology*, July 2nd, 1998
- [10] Ahmed Ibrahim, Yeong Ryu, and Mir Saidpour "Stress Analysis of Thin-Walled Pressure Vessels" *Modern Mechanical Engineering*, 5, 1-9, February 3rd 2015
- [11] Shyam R Gupta and Chetan P. Vora "A review paper on pressure vessel design and analysis" *International Journal of Engineering Research and Technology* Vol.3 Issue 3, March 2014
- [12] Vijay Kumar and Pardeep Kumar "Mechanical design of pressure vessel by using PV-Elite software" *International Journal of Scientific and Research Publication*, Volume 4, Issue 4, ISSN 2250-3153, April 2014
- [13] P. C. Tewari, Rajiv Kumar, and Dinesh Khanduja "Performance Modeling and Availability Analysis of Yarn Dyeing System of a Textile Industry" *World Academy of Science, Engineering and Technology, International Journal of Mechanical, Aerospace, Industrial, Mechatronic and Manufacturing Engineering* Vol:7 No:12, 2013
- [14] Abu Shaid, Md. Abu Bakar Siddiquee "Studies on Reverse Tension Mechanism of Cheese Dyeing" *Daffodil International University Journal of Science and Technology*, Volume 6, Issue 2, July 4th, 2011
- [15] Nobutaka Ono, "Method of Dyeing Yarn Cheeses" *United States of Patent*, Patent no: 5351351, Oct 1994.