

# HAND GESTURE BASED HOME APPLIANCES CONTROL SYSTEM

Jyoti Jadhav<sup>1</sup>, Prashant Avhad<sup>2</sup>

<sup>1,2</sup>Professor, Dept. Of E&TC Engineering, DYPCOE, Ambi, Maharashtra, India

\*\*\*

**Abstract** - This Paper presents a system for Hand Gesture controlled user interface. This proposed system used to control the function of various home appliances. This system is basically designed for the visually challenged people to aid them in operating the home appliances individually. In this system MEMS accelerometer is used to detect hand motion and transmitted using Radio Frequency (RF). This paper presents a low-cost and 3-axis wireless accelerometers based system to control the Home Electronic devices using ARM7. This system consists of Gesture identifying and control module with Micro-electromechanical systems sensor and home appliances control. ARM7 is the main part of gesture identification. The MEMS sensor which is connected to hand is a xyz-axis accelerometer which senses the gesture of the hand and the home electronic devices control unit is controlled using LPC2138 controller. This project proposes a simple and easy Method of controlling the home appliances.

**Key Words:** MEMS accelerometer, ARM7, Hand Gesture, Radio Frequency, Gesture identifying etc.

## 1. INTRODUCTION

Basic purpose of developing new system of hand gesture remote control is to remove the need of the hand held remote. Gesture is an action of arms or any other body part which are made to emphasize speech. Basically Gestures include motion of the hands and face. A gesture can be divided into different categories: dynamic gesture and static gesture. Gesture recognition is movement of human action by computing device. Gestures can obtain from any bodily motion but commonly obtain from the face or hand.

The basic purpose of this system is to control different electronic devices with the help of hand movement. Thus, this system will work as a remote control for operating different electronic devices present in a daily use.

We are using gestures of hand as a remote to controlled home appliances like Tube; fan etc. instead of using manually. Now a days, in each and every home all electronic equipment's like TV, CD player, air conditioner, DVD player and music system that can be operated with the help of RF module. Here we used our hand like Remote for controlling home appliances. All these home electronic devices can be controlled by transmitter- receiver system.

Now days, it is impossible for living in a home without interacting with the home appliances. Due to evolution of technology in the field of gesture recognition for hand

gesture or human computer interaction many Techniques are done. Here the Hand mote is referred to as use of hand gesture recognition to control and work the home and office electronic devices that are operated through an RF module.

## 2. PROPOSED SYSTEM

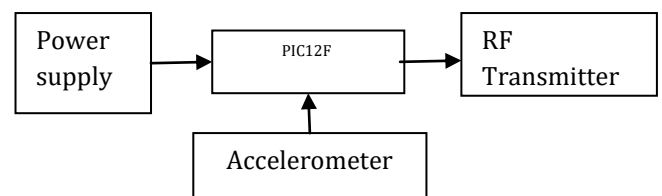

Fig -1: Block Diagram of Transmitter Module

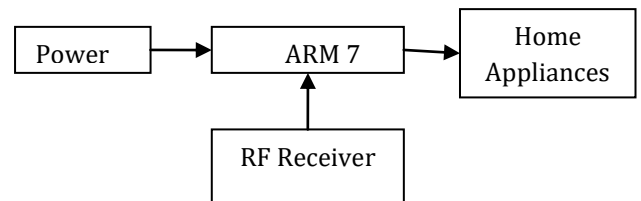

Fig -2: Block Diagram of Receiver Module

MEMS accelerometer based home appliances controlled system is designed for visually challenged and partially paralyzed persons. The system Consist of accelerometer, microcontroller, one RF transmitter module and one receiver Module and the communication is through RF signals. In this system the accelerometer senses different hand gestures and particular signal is transmitted to receiver section through RF transmitter. RF receiver module receives the transmitted signal compares it with the previously stored gestures and when hand gestures are matched with each other, then the home appliances are controlled.

### 2.1. RF Transmitter Section

The hand gestures are detected by using three axis MEMS accelerometers which is placed in the gloves to be worn by the person. The detected signals are passed to the ARM7 that is powered by 5V. The signal from ARM7 is given to the RF transmitter. The RF transmitter operates at a frequency of 434 MHz, transmits the signal to the RF receiver.

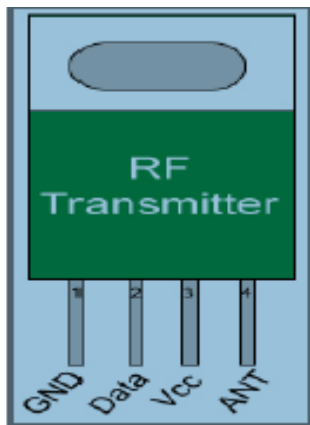

Fig -3: RF Transmitter.

### 2.2. RF Receiver Section

The transmitted signal is obtain by an RF receiver operating at the same frequency as that of the transmitter. Obtain signal is given to the ARM7 which compares the received and pre-save hand gestures, and if signal is matched then the particular signals are given to the home appliances to control them.

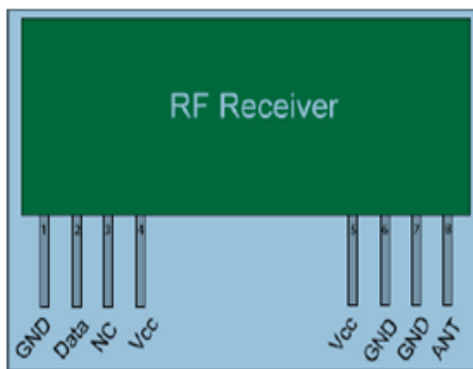

Fig -4: RF Receiver.

### 2.3. MEMS Accelerometer

MEMS accelerometers is micro-electromechanical systems used to measure the force of acceleration. In the proposed system accelerometer sensors are used for interaction with home electronic devices using recognized hand gestures.

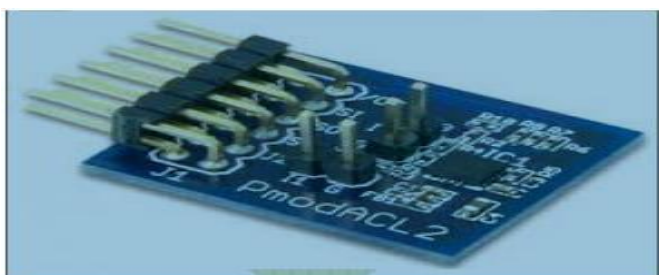

Fig -5: MEMS accelerometer.

### 3. FLOWCHART

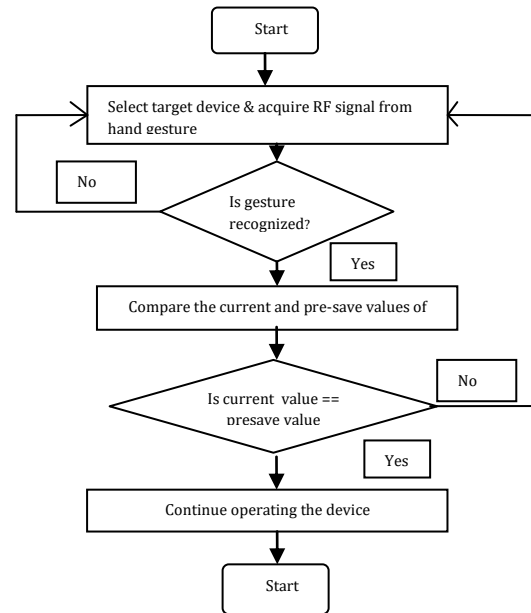

Fig -6: Flowchart for GESTURE controlled devices

### 4. APPLICATIONS

- It can be used in any RF device.
- It is use full to situations where normal cabling is difficult or financially impractical.
- It is use full for physically challenged people AND aged persons to operate the devices within the room.

### 5. RESULTS

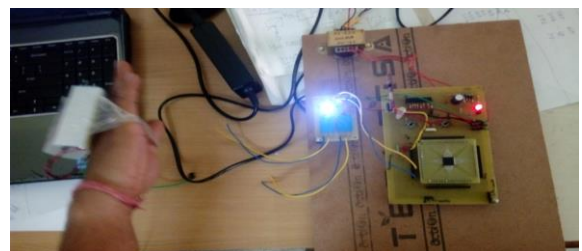

Fig -7: Left Gesture

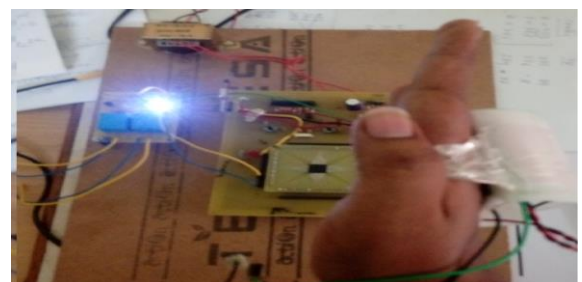

Fig -8: Right Gesture

## 6. CONCLUSIONS

The objective of this project is to develop such a system which will help physically challenged people to control home Electronic devices by hand gestures using accelerometer. The device helps the aged persons too. In future Wireless Bluetooth technology is also used for home automation for physically impaired.

## REFERENCES

- [1] ShiguoLian,Wei Hu, Kai Wang, "Automatic User State Recognition for Hand Gesture Based Low-Cost Television Control System",IEEE,2014.
- [2] J. Sathyan and A. R. Ramakrishnan,"A Unique Self-Contained Universal Remote Control",IEEE 2004.
- [3] N. Sriskanthan , F. Tan , A. Karande , "Bluetooth Based Home Automation System",Elsevier Science B.V.-Microprocessors and Microsystems ,10 May 2002.
- [4] Ahmad Akl ,Chen Feng and ShahrokhValaee ,"A Novel Accelerometer-Based Gesture Recognition System", IEEE Transactions On Signal Processing, Vol. 59, No. 12, December 2011.

## BIOGRAPHIES



Mrs. Jyoti Jadhav is Assistant Professor in DYPCOE,Ambi,Pune.



Mr. Prashant Avhad is Assistant Professor in DYPCOE,Ambi,Pune.