

IoT Based Portable Attendance Device using Bio-metric System

Aniket Shete¹, Prashant Nangare², Rahul Thakre³

¹²³B.E Final Year Students, Electronics and Telecommunication, N.M.I.E.T. Pune, Maharashtra, India

Abstract - In recent past, a rapid growth in the number of applications based on Bio-metric and have been successfully applied to different areas as diverse as education, government offices, transportation, health-care and hospitality industry to name a few. Bio-metric technology facilitates automatic person identification using pre-restored finger expression.

In this paper, an attempt is made to solve manual class attendance monitoring problem in developing countries using IoT and Bio-metric technology. The application of Bio-metric system using IoT to student attendance monitoring as developed and deployed in this study is capable of eliminating time wasted during manual collection of attendance and an opportunity for the educational administrators to capture face-to-face classroom statistics for allocation of appropriate attendance scores and for further decisions. Internet of things (IoT) is used to monitor and manipulate the data stored on server. IoT does the work of sending the data stored in device to the server using GPRS

Key Words: IOT, BIO-METRIC, GPRS

1. INTRODUCTION

The availability of upper end high speed internet has provided almost all the information, which causes the students to be less interest in attending the classes in their working hours. Laziness on the part of students, unconcerned to college work, additional social activities that have no importance in aiding the objectives of the institution and a lot more, may prevent students from attending classes. Consequently, professors and administrators in most developing countries have had to come up with ways to ensure a healthy participation from students, and make sure that the student-teacher interactive relationship is kept intact. This in some cases have come in simple forms like roll calls, while in more interesting cases, can be formats like surprise quizzes, extra credit in class, etc.

These strategies are however time consuming, stressful and laborious because the valuable lecture time that could otherwise been used for lectures is dedicated to student attendance taking and sometimes not accurate. In addition to all these challenges, the attendances are recorded manually by the tutor and therefore are

prone to personal errors. There arises a need for a more efficient and effective method of solving this problem.

A technology that can solve this problem and even do more is the IoT based Bio-metric technology. Bio-metric is an automated identification and data collection technology, that ensures more accurate and timely data entry. Bio-metric is not actually a new technology; it only quickly gained more attention recently because of its current low cost and advances in other computing fields that open up more application areas.

Bio-metric systems work by recording and comparing bio-metric characteristics. In many cases, characteristics are recorded as images, and for speaker recognition waveform is recorded, and for signature recognition, time series data to create a smart system. Bio-metric module captures a digital image of fingerprint pattern. The capture image is called a live scan. This live scan is digitally processed to create a bio-metric template which is stored and used for matching.

A bio-metric module has two basic jobs-it need to get an image of your figure, and it need to determine whether the pattern of the ridges and valleys in this matches the pattern of ridges and valleys in pre-scanned image. Only specific characteristics, of fingerprint is ever saved, only a series of number (binary code), which is used for verification. The algorithm cannot be reconverted to an image, so no fingerprint can be duplicated. GPRS module is used to send a data stored in device over the Internet after the end of particular session.

2. MATERIALS AND METHOD

The primary purpose of an Bio-metric system in this application area is to detect the presence and absence of the student data to be transmitted wirelessly by GPRS module, which can be read by authorized user on their devices with the help of user ID and password, device can be personal computer (PC) or smart phone. The ease with which biometric system can be integrated into current operations depends on the openness and flexibility of the technology infrastructure especially the IoT that will be used to transmit the data over the internet or server. The

proposed system provides solution to lecture attendance problem through coordinated hardware and software design handshaking data communications between Bio-metric module and GPRS module serially interfaced to the Chip LPC2148. The IoT based smart attendance device using biometric module from Fig. 1 was designed around ARM7 microcontroller LPC 2148.

The developed attendance management system in this work abides by the following hardware and design considerations described as follows.

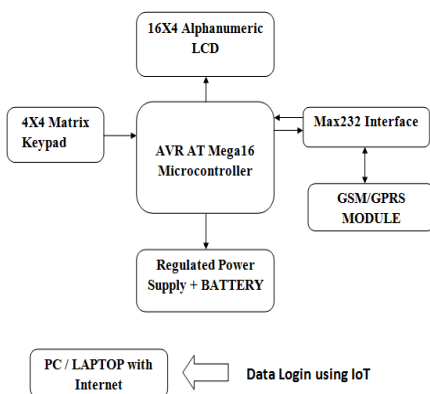

Fig-1: Block diagram of IoT based Bio-metric Attendance system.

3. HARDWARE DESIGN CONSIDERATIONS

The signals from the keypad & I/O ports are given to the Microcontroller. Keypad is 4x4 alphanumeric keypad. 0 to 9 numbers can be used by using 4x4 alphanumeric keypad. As in a figure Microcontroller ARM7 LPC 2148 is used. EEPROM is inbuilt part of microcontroller LPC 2148. LCD, keypad, Max232, GPRS module, Bio-metric module all are interfaced with the microcontroller LPC2148. Microcontroller processes all these signals and gives data to LED display and computer which are connected parallel to each other. Also connected EEPROM & interface with Max232. Keypad will be used to set different modes, enter logging ID & password, Select menu, Edit or Send keys etc. The LCD display interfaced with the microcontroller shows every instantaneous situation of the process running in microcontroller. It is used to show current time and various messages. EEPROM is also connected to the microcontroller. All the attendance is stored in EEPROM. This section is the energy source of the project which provides power to processor to perform its tasks. Battery is use for power supply. Max232 is use as trancreciever. GPRS is use for

sending data to PC/laptop. GSM is use for sending for message. GSM/GPRS module will connect the device to internet. PC or laptop we create visual basic software for attendance data logging that is in responsible person PC. In visual basic software all attendance record is logged with Name, Subject, date & time Use for take attendance to enroll the fingerprint the finger of student.

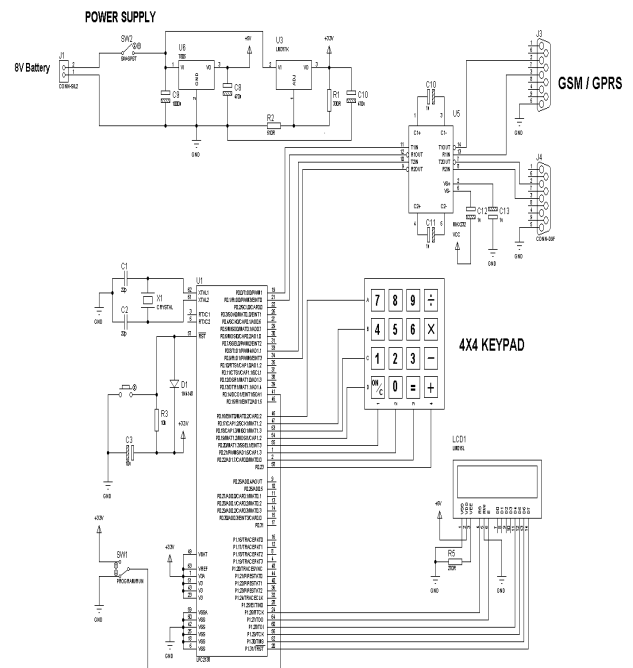

Fig-2: Circuit diagram of IoT based Bio-metric Attendance system.



Fig -3: Biometric demo kit

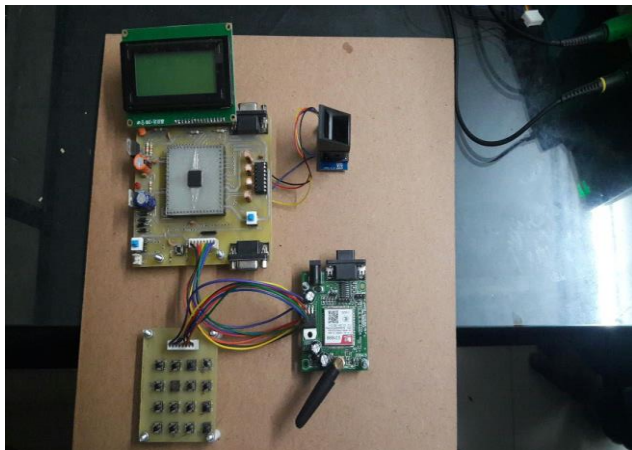

Fig-4: IoT based biometric attendance system setup

4. SOFTWARE DESIGN CONSIDERATIONS

In the development cycle of the system, decisions were made on the parts of the system to be realized in the hardware design and the parts to be implemented in software. The software is decomposed into modules so that each module can be individually tested as a unit and debugged before the modules are integrated and tested as a software system in order to ensure that the software design meets its specification. The program was written in C++ programming language. C++ enables the rapid application development (RAD) of graphical user interface (GUI) applications. Programming in C++ provides the user with the ability to utilize a combination of visually arranged components or controls on a form, specifying attributes and actions of those components, and writing additional lines of code for more functionality. The software was designed using the flowchart shown in Fig. 5. For authorities to read or manipulate database web pages have been made. According to the user different web pages have been created which will allow user to access a database on server. In order to read or manipulate every user have to log in into the system first. Web pages are as shown in fig.6 and fig.7

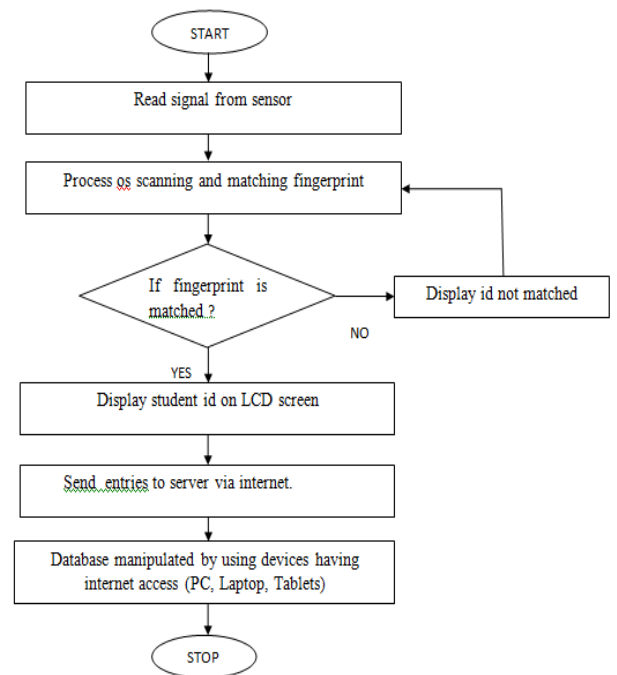

Fig-5: Flowchart of purposed system

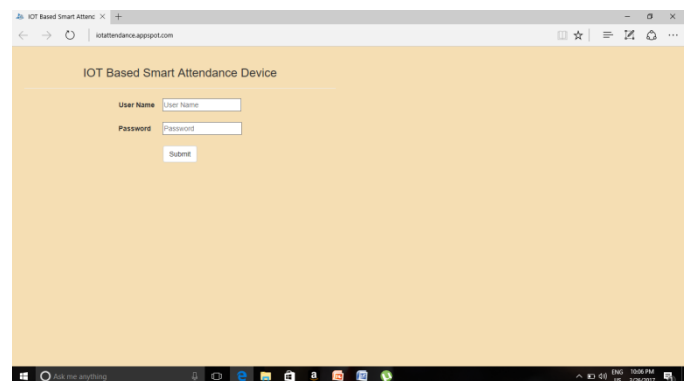

Fig-6: Web page on server for login

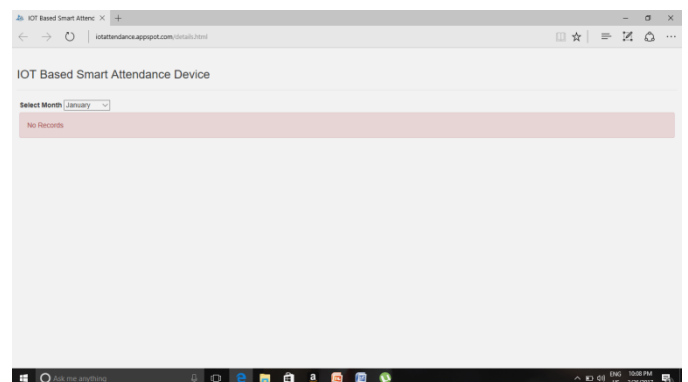

Fig-7: Access to database on server

3. CONCLUSIONS

As the IoT based Bio-metric technology evolves, more sophisticated applications will use the capability of IoT based bio-metric to receive, store and forward data to a remote sink source. IoT based bio-metric has many applications as can be imagined. In this paper, we have utilized the versatility of IoT based biometric in implementing functional and automatic student course attendance recording system that allows students to simply fill their attendance just by pressing their thumb over a fingerprint module and most importantly it will not be time taking as the device is portable. We hope that this system can shift the paradigm of students lecture attendance monitoring in face-face classroom and provide a new, accurate, and less cumbersome way of taking student attendance in educational institutions.

REFERENCES

- [1] Abdul Kadir¹, Mohd Helmy Abd Wah Ab², Zarina Tukiran, Ariffin Abdul, Tracking Student movement using RFID HERD AWATIE Faculty of Electrical and Electronic Engineering Universiti Tun Hussein Onn Malaysia, Batu Pahat, Johor, ISSN: 1790-5117, ISBN: 978-960-474-1663 MALAYS.
- [2] Dawes A.T. (2004), "Is RFID Right for Your Library", Journal of Access Services, Volume 2(4), pp 7-13
- [3] Longe (2009) ,Implementation of Student Attendance System using RFID Technology, B. Tech Project Report, Ladoke Akintola University of Technology, Ogbomoso, Nigeria.

Authors:



Aniket shete
Shete.aniket552gmail.com



Prashant Nangare
Prashantnangare123gmail.com



Rahul Thakre
Rahulthakre38gmail.com