

# Low Cost Weather Monitoring Station Using Raspberry Pi

Pravin Baste<sup>1</sup>, Prof. D. D. Dighe<sup>2</sup>

*Department of Electronics and Telecommunication,  
Matoshri College of Engineering & Research Centre, Eklahare, Nashik,  
Savitribai Phule Pune University, India.*

\*\*\*

**Abstract** - In this paper, we have designed, developed and tested a low cost weather monitoring station using raspberry pi, which monitor the weather data, including wind speed, wind direction, air temperature, humidity, atmospheric pressure, rain, and solar radiation. Weather data are sent via Wi-Fi network to a database server as well as it stored in memory card. On the other hand, a web application which presents acquired weather data at remote locations. This system provides real-time data acquisition and transfer of measured parameter like other high cost commercial weather station. It is very low cost, small size, easy use and reliable which can be easily used in various applications.

**Key Words:** weather station, raspberry pi, wind sensor, temperature, humidity, solar radiation

## 1. INTRODUCTION

The weather station is an Electronic system which used to measure the weather parameter like wind speed, wind direction, air temperature, humidity etc. Weather condition plays very important role in various fields such energy sector, agriculture, space science etc. Due to the huge importance of weather influence to human life motivated of whole scientific areas devoted to weather observation.

Initially a simple and less accurate devices were used, Nowadays, advanced weather stations around the world which used to monitor weather parameter continuously.

Weather condition plays very important role in various fields such energy sector, agriculture, space science etc. Due to the huge importance of weather influence to human life motivated of whole scientific areas devoted to weather observation. Initially a simple and less accurate devices were used, Nowadays, advanced weather stations around the world which used to monitor weather parameter continuously.

These measured parameter useful only when it sends a fast and accurate manner. Therefore, data transfer and processing is very important parameter in weather monitoring station. Now dedicated instruments used for sensing, processing & data transfer combination of all known as a weather station. Measured data can be transferred through such medium as a direct wired link, Wi-Fi, GSM, satellite link and so on.

The common objective, which is widely used, is a weather forecast. Weather monitoring has a different purpose, such as a research on global warming, climate change, real time

weather monitoring of the remote location, agriculture etc. [5]. It also used for commercial application and educational purpose. Weather monitoring station shall be reliable and highly accurate. Also, it shall be facility for access to the measured parameter eased. The accuracy of sensor shall be higher because this factor will directly affect your collected data. The modern weather station has a separate data logger unit with the transferring facility with your website or personal computer. Weather condition drastically changed that time it should work properly. Some manufacturer provided a limited option for the user. If any changed in weather station some time user need to buy other compatible devices. So the system should flexible in case any changed in weather station there should be configurable solved. Commercial products can be expensive for some specific application. Due to high cost weather station not easily available which directly effect on research related to weather parameter. This factor motivated us to design and developed our own low cost weather monitoring station.

In this paper, we will present our low cost weather monitoring station using raspberry pi solution designed, developed and tested for particular purposes. Using the low cost component, we designed and developed a weather monitoring station for measuring wind speed, wind direction, air temperature, air humidity, atmospheric pressure, rain and solar radiation. In order to collect and present measured data, we developed web application.

The whole paper is arranged as follows, In section II overview of the commercial weather station with its drawbacks is presented. In section III Architecture of proposed weather monitoring system is described. Testing and result in section IV. In section V conclusion remarks are described.

## 2. DRAWBACKS OF COMMERCIAL WEATHER STATIONS

Commercial weather station basically consists of only few weather parameters such as wind speed, wind direction, humidity. This weather station also equipped with data loggers for storing data and wireless data transfer facility. Such commercial product hard to modify when user required high accuracy [1]. In such a case user just user just gets specific parameter which is provided by the manufacturer.

For the other parameter user need to buy a new system for parameter like atmospheric pressure, rain, solar

radiation. Some commercial products have very complex functionality and it's hard to use. In some application where robustness is not important and the cost of such commercial product makes them inapplicable. Remote weather stations also too expensive because it required costly battery unit.

Measured data by commercial weather station sent to data logger which is placed near the weather station. So in such case user need to purchase a communication unit that will help to transfer data through GPRS or WI-FI to manufacturer's website. It would earn additional cost for GPRS communication and manufacturer designed website. These are some main reason to design and develop own weather monitoring station based low cost available resources with high accuracy [2].

### 3. AN ARCHITECTURE OF DEVELOPED WEATHER MONITORING STATION

In the initial phase of designing of weather monitoring station, our main task was the selection of efficient and flexible development tool. So we decided to designed weather monitoring system using the raspberry pi board. The raspberry pi board provides us flexible solution, when network communication is required. It has on board Bluetooth, WI-FI, Ethernet port for network communication. Raspberry pi integrated with USB port, 3.5 mm audio jack, HDMI port, GPIO port and micro-SD slot. Raspberry pi board, provided us all features in single board with low power consumption [3].



Fig. 1. Raspberry Pi 3 Model B

For hardware development, we used less expensive component to maintain low cost of weather monitoring station. By using on board Wi-Fi, we transmitted data from where data are measured to a remote location where users can access this data.

Web application specially developed for monitoring which will show real time weather data on your personal computer, laptop, and Smartphone. The raspberry pi

board also itself works as Data logging unit because measured data also stored in Micro-SD memory card.

Low cost weather monitoring station combination of such components:

- Raspberry pi 3 Model B
- Wind speed sensor
- Wind direction sensor
- Rain sensor
- BME 280 for air temperature, Humidity and atmospheric pressure sensor
- Pyranometer (Solar Radiation sensor)

Raspberry pi 3 Model b has 40 Pin GPIO which gives us the best option for interfacing of weather sensor. It also had four USB ports where the operator can attach four input output devices. For communication purposes, we used on board Wi-Fi, which can be easily configured with wireless access point. Commercial wireless access point also used for establishing connections between the local network and raspberry pi. Once turn on the weather monitoring station, it starts with measured weather data. This measured data continuously stored in micro-SD memory card and transferred to database server. This stored data on the server can access through a web application. Direct communication form between user and weather monitoring station of IP network, which provide the best option for fast data transfer. In our case user can access real time weather data by using a web application. We used IP network for communication between user and weather monitoring station.

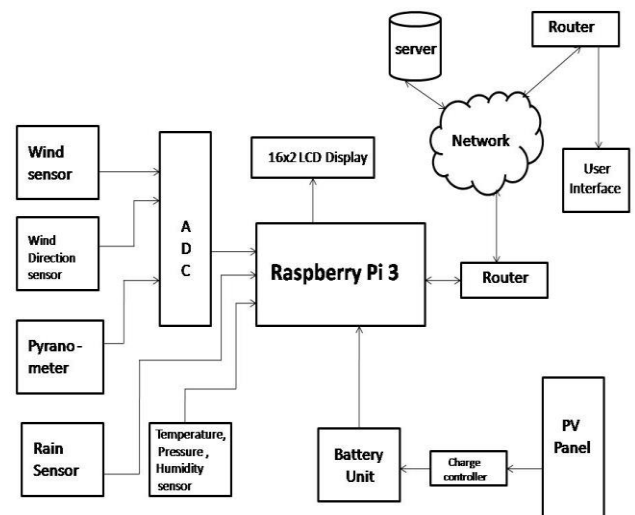

Fig. 2. Block Diagram of Low Cost Weathering Monitoring Station Using Raspberry Pi 3

Weather monitoring station has of 16x2 LCD display to show measured data. Weather station provides information about wind speed, wind direction, air temperature, atmospheric pressure, humidity, rain and

solar radiation. Developed weather monitoring station shown in Fig. 2.

In weather monitoring station, we used five major sensors such as wind speed sensor, wind direction sensor, rain gauge, pyranometer and BME 280 for air temperature, humidity and atmospheric pressure. Three sensors required ADC (Analogue to digital converter ) then it interfaced with raspberry pi and remaining sensors are directly interfaced with raspberry pi.

### A. Wind Speed Sensor (Anemometer)

The most common kind of wind sensor is a kind of horizontal three-armed propeller, with a concave hemispherical cup on the end of each arm.

The air pressure on the inside of the cup, which help push the cups and due this it start to revolve at more than two-fifth the speed of the wind. This cup are fixed with arm on one point.

Wind speed sensor is used for measuring wind speed by closing magnet switch. Wind speed sensor is used for measuring wind speed by closing magnet switch. Due to switch close to per second causes 1.492 MPH or 2.4 km/s wind speed [4].



Fig. 3. Wind Speed Sensor

### B. Wind Direction Sensor

The wind direction sensor has eight switches. Every switch is joined with different values of resistor.

Two switches may close at the time due to the magnet. The voltage divider is formed by using external resistor, which producing a different output voltage for each switch. By using ADC we can measure the output voltage. Eight different resistor values give sixteen possible position. [4]



Fig. 4. Wind direction sensor

### C. Rain Gauge

The rain gauge used for measuring rain. The rain gauge have mechanism of self-emptying tipping bucket type. Its consist of funnel used collects and send the precipitation into a small size seesaw.

When a pre-set amount of precipitation falls. The momentary contact will form, then collected water will release. One momentary contact closure caused 0.011" (0.2794mm) of rain.This can be recorded with a digital counter. [4]



Fig. 5. Rain Gauge

### D. BME 280 (air temperature, humidity, atmospheric pressure sensor)

The BME 280 is an integrated with air temperature, relative humidity, barometric pressure sensor.Which is specially developed for mobile application where low power consumption and size are main parameter for design. This sensor combines with high accuracy, high linearity for pressure, humidity and temperature.This sensor has 8 pin metal lid 2.5 x 2.5 x 0.93 mm<sup>3</sup> LGA



package. Designed for low current consumption 3.6μA @1Hz with long term EMC robustness and stability. [5]



Fig. 6. BME 280 (air temperature, humidity, Atmospheric pressure sensor)

**E. Pyranometer (Solar Radiation Sensor)**

A Pyranometer (solar radiation sensor) used for measuring solar radiation. It is designed to measure global solar radiation flux density (W/m<sup>2</sup>).

This pyranometer has a silicon cell type. This type pyranometers are made up by using of photodiode. When the photodiode exposed to sun (solar radiation) that time it produce current. This current amplify by using amplifier which is helping to measured final output. This type of pyranometer are capable to measure a narrower band of radiation. When it compared with thermopile type of pyranometer that time we required correction factor to compensate the error. The sensor works in wavelengths between 350nm to 1150nm. [6]



Fig. 7. Silicon Pyranometer

**F. Web Application.**

In weather monitoring station, access weather data is so important. Therefore, We developed web application which consist of database server and web site.

The database is developed by using MySQL. Because weather data is so important to know weather pattern. By

using a database, Raspberry Pi continuously uploads data to the database.

This data can be accessed by web page. Therefore weather data can be easily accessible for distant location. Due to web application user can get real time data. Remote location, weather monitoring directly helps in analysis and user shall easily save time and money. Web Page shown in fig. 8.

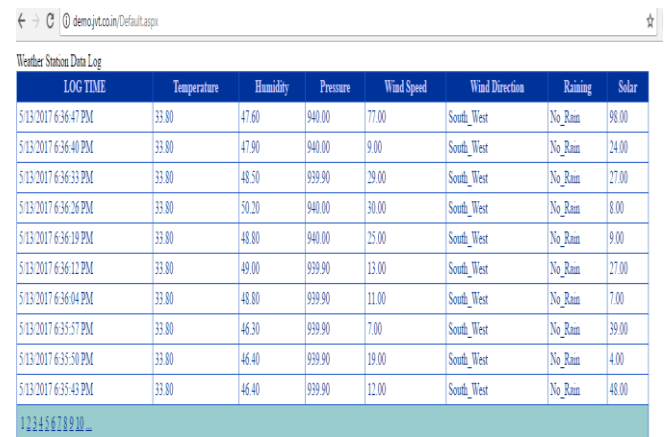

LOG TIME	Temperature	Humidity	Pressure	Wind Speed	Wind Direction	Raining	Solar
5/13/2017 6:36:47 PM	33.80	47.60	940.00	77.00	South_West	No_Rain	98.00
5/13/2017 6:36:40 PM	33.80	47.90	940.00	9.00	South_West	No_Rain	24.00
5/13/2017 6:36:33 PM	33.80	48.30	939.90	29.00	South_West	No_Rain	27.00
5/13/2017 6:36:26 PM	33.80	50.20	940.00	30.00	South_West	No_Rain	8.00
5/13/2017 6:36:19 PM	33.80	48.80	940.00	25.00	South_West	No_Rain	9.00
5/13/2017 6:36:12 PM	33.80	49.00	939.90	13.00	South_West	No_Rain	27.00
5/13/2017 6:36:04 PM	33.80	48.80	939.90	11.00	South_West	No_Rain	7.00
5/13/2017 6:35:57 PM	33.80	46.30	939.90	7.00	South_West	No_Rain	39.00
5/13/2017 6:35:50 PM	33.80	46.40	939.90	19.00	South_West	No_Rain	4.00
5/13/2017 6:35:43 PM	33.80	46.40	939.90	12.00	South_West	No_Rain	48.00

Fig. 8. Web Page

**4. TESTING AND RESULT**

The developed system shown in fig. 9. (a) & 9. (b)



(a) Raspberry Pi with LCD Display and ADC  
(b) Sensor Unit

Testing of weather monitoring station is conducted at different weather condition. To check drastic changed in weather condition, how the system will respond. So testing was conducted during the day as well night condition. The result shown in below table.

Table 1. Testing Data of Day Time:

Time	Air temp. (°C)	Wind speed (m/s)	Wind Direction	Humidity (%)	Rain	Solar Radiation (W/m <sup>2</sup> )
11:00	30.32	1.89	S_W	32.32	No_Rain	630
11:03	30.91	0.78	S_W	33.56	No_Rain	636
11:06	31.05	1.56	S_W	34.39	No_Rain	680
11:09	31.56	1.32	S_W	29.36	No_Rain	690
11:12	31.75	0.91	S_W	35.38	No_Rain	730



Fig. 11. Notification of data transfer to server on LCD Display

The remote monitoring facility also checked, it was working properly and continuously updating data on a web page with sampling time 3 sec.

Web page for the system shown in fig. 12.

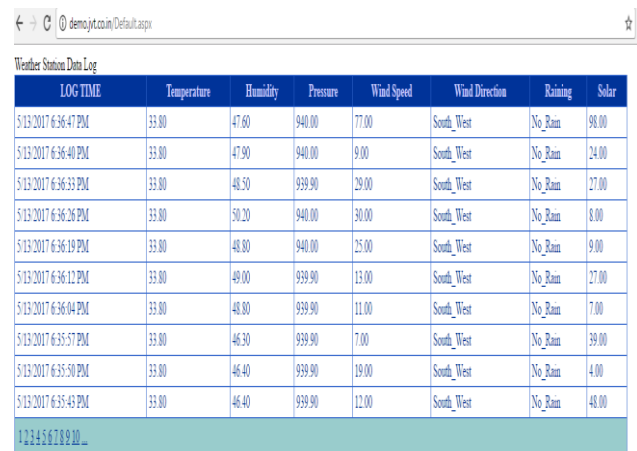

LOG TIME	Temperature	Humidity	Pressure	Wind Speed	Wind Direction	Raining	Solar
5/13/2017 6:36:47 PM	33.00	47.60	940.00	77.00	South_West	No_Rain	90.00
5/13/2017 6:36:40 PM	33.00	47.90	940.00	9.00	South_West	No_Rain	24.00
5/13/2017 6:36:33 PM	33.00	48.50	939.90	29.00	South_West	No_Rain	27.00
5/13/2017 6:36:26 PM	33.00	50.20	940.00	30.00	South_West	No_Rain	8.00
5/13/2017 6:36:19 PM	33.00	48.80	940.00	25.00	South_West	No_Rain	9.00
5/13/2017 6:36:12 PM	33.00	49.00	939.90	13.00	South_West	No_Rain	27.00
5/13/2017 6:36:04 PM	33.00	48.80	939.90	11.00	South_West	No_Rain	7.00
5/13/2017 6:35:57 PM	33.00	46.30	939.90	7.00	South_West	No_Rain	39.00
5/13/2017 6:35:50 PM	33.00	46.40	939.90	19.00	South_West	No_Rain	4.00
5/13/2017 6:35:43 PM	33.00	46.40	939.90	12.00	South_West	No_Rain	40.00

Fig. 12. Weather Data on Web Page

Table 2. Testing Data of Night Time:

Time	Air temp. (°C)	Wind speed (m/s)	Wind Direction	Humidity (%)	Rain	Solar Radiation (W/m <sup>2</sup> )
7:12	28.32	1.95	S_W	51.32	No_Rain	00
7:15	28.52	2.02	S_W	51.56	No_Rain	00
7:18	28.21	1.56	S_W	51.39	No_Rain	00
7:21	28.84	1.74	S_W	51.36	No_Rain	00
7:24	28.75	1.96	S_W	51.38	No_Rain	00

Complete observation of the whole system is carried out, In that we observed data logging which was working properly. Data was logging properly with sampling time of 3 sec. That reading also displayed on 16x2 LCD display, which shown in fig. 10. & fig. 11.



Fig. 10. Weather Data on LCD Display

### 5. CONCLUSION

In this paper, we introduced one feasible solution for low cost weather monitoring station that we developed. The main aim was to design a low cost, small size and useful solution for real-time weather monitoring and logging in school, colleges, research center. By Using the sensor for wind speed, wind direction, air temperature, humidity, atmospheric pressure, rain and solar radiation integration with raspberry pi 3, we created a model of the weather monitoring station.

Weather data are sent via Wi-Fi network to a database server as well as it stored in memory card. Due to the database server, which help to access data from any remote location. So it helps to store and process data in order to develop an expert decision making system for various applications.

This model of low cost weather monitoring station may consider as a first step towards development and commercialization of economically affordable, easy to use, small in size but reliable weather monitoring station.

**REFERENCES**

[1] Geonica Earth Science <http://www.geonica.com> (URL)

[2] One approach to weather station design based on Raspberry Pi platform Trifun Savić; Milutin Radonjić 2015 23rd Telecommunications Forum Telfor (TELFOR)

[3] Raspberry pi: <https://www.raspberrypi.org/>(URL)

[4] Weather assembly: <https://www.sparkfun.com/datasheets/Sensors/Weather> (URL)

[5] BME 280: <https://www.adafruit.com/product/2652> (URL)

[6] Pyranometer: <http://www.aeronsystems.com/types-of-pyranometers/>

[7] Low cost weather station for climate-smart agriculture Sonam Tenzin; Satetha Siyang; Theerapat Pobkrut; Teerakiat Kerdcharoen 2017 9th International Conference on Knowledge and Smart Technology (KST) Year: 2017