

Solar powered automatic grass cutter and pesticide spreading robot

Argade Pratik Pralhad¹, Bhosale Swapnil Bhagwan², Khadke Sagar Subhash³, Phadtare Nikhil Vijay⁴, Prof.Kale R.U⁵

^{1,2,3,4}B.E ,Dept. of E&tc Engineering, S.B. patil college, Indapur, Maharashtra, India

⁵Guide, Dept. of E&tc Engineering, S.B. patil college, Indapur, Maharashtra, India

Abstract: A Solar Powered Automatic Grass Cutting And Pesticide Spreading robot project is mainly proposal for reduce the manpower and usage of electricity. Solar plate is used to provide the source to the battery charging. It is an automated system for the purpose of grass cutting. The source is drive from the solar energy by using solar plate. The system control is done by the Arduino UNO R3. Automation is achieved by using sensors and Arduino UNO R3. Wheels and cutting operations are done using dc motors. DC battery is utilized for powering and standby mode operation of the system. The whole supply is provided through the battery and to charge the battery charger circuit is used to provide the charging for the battery.

Also the second application is that the spreading of pesticide here we used the water pump with spreading nozzle.

Keywords: (Arduino UNO R3, pic18f4520, Ultrasonic Sensor, DC motor driver, DC Motor, RF434MHz Transmitter and receiver, 12V dc pump).

1. INTRODUCTION: In this project we are using wireless technology for home automation. A home automation system is a means that allow users to control electric appliances of varying kind. The main aim of the project is to develop a system that will control of home appliances .the basic requirement or need is android app because of we are overall home appliances through android app. Home automation systems develop to automatically achieve some activities performed frequently in daily life to obtain more comfortable and easier life environment. In home automation that can detect and identify you, automatically adjust the lighting to your predefined taste, open doors automatically, at night and switch them off in the morning, stream to you anywhere in the world via the internet. It is meant to save the electric power and human energy. IoT coverage is very wide and includes variety of objects like smart phones, tablets. Once all these devices are connected to each other, they enable more and more smart processes and services that support our basic needs.

In our project we are giving two facilities automatically operation and manually operation. We are operate home automation by automatically as well as manually it is totally depend on our choice. if some problem occurs in the automatically we can use manually.

1.1 Problem Statement

To built a Intel Galileo board Ethernet/Wi-Fi to control all the electric/electronic device connected to switches to provide more flexibility of doing thing and above securing homes or workspaces.

1.2 Literature Survey

Solar Powered Automatic Lawn Mower Lawn Buddy. This design contains a microcontroller, multiple sensors, and a solar charging system. Adding these elements together, they get their robotic lawn mower. [1]. Automatic grass cutting machine by using photovoltaic source and motor speed control. It is an automated system for the purpose of grass cutting. The source is drive from the solar energy by using photovoltaic panels from the photovoltaic panel and store the DC voltage in a battery.[2]. Autonomous Pesticide Spraying Robot for use in a Greenhouse.

This paper presents an engineering solution to the current human health hazards involved in spraying potentially toxic chemicals in the contained space of a hot and steamy glasshouse. [3]. ARM- Based Pesticide Spraying Robot. The main use of robots in agriculture is for harvesting ,Fruit picking , driverless tractor or sprayer are design to supersede human labor. Main aim is to avoid manual spraying of pesticides at actual farm. It will achieve by replacing human by a robot, through transmission of video of crop to central station.[4]. Development and Automation of Robot with Spraying Mechanism for Agricultural Applications. This is achieved by the design and construction of an autonomous mobile robot for use in pest control and disease prevention applications in commercial Farm. The effectiveness of this platform is shown by the ability to successfully navigate itself down rows of a Farm, spray the pesticides effectively while the farmer controls it from a far distance. And this pesticide spraying system efficiently covers the plants evenly with spray in the set dosages. [5].

2. BLOCK DIAGRAM

There if one RF remote in the users hand to give the instruction to the robot. According to users command robot will act as the there is large area of grass and the user is using auto mode so the robot will work automatically using ultrasonic sensor.

But as the user using manual mode in that the user has to give the command for the robot movement and for application of grass cutting or pesticide spreading .For grass cutting purpose we are using 32000 rpm motor with hand made bled.

2. WORKING

In this project the main part is the Arduino UNO R3 which control the all assembly of project. The user is with the RF control remote , the user has to select that in which mode the system has to operate either it is in manual mode and the auto mode in manual mode the user has to decide that where to move robot but in auto mode the robot will decide that where it wants to go . By using ultrasonic sensor the robot will move. The blade of the robot is hand made design the motor used for the cutter is the brush less dc motor and it has the rpm of 35000 it operates on 12v dc supply.

The battery is source part for the project the battery is supplying the 12v dc for the motor and pump. The Charged on the solar plate once the battery is fully charged the robot will move properly. Also the second application is the pesticide spreading here we use the 12v dc operated pump with the 1.5m length pipe and the spreading nozzle is connected at the one end of the pipe. For supplying water to the and storing pesticide we use the water tank of 2 liter. RF control remote used here has the range of 300ft(100m) . In this range the use has to give instruction to the robot. The RF uses the frequency of 434MHz and we use the encoder and decoder ic at the transmitter and receiver respectively. The ic are HT12E and HT12D . Also at transmitter the with encoder ic we use the another ic PIC181f4520 because the encoder ic is the 4 bit encoder but we require the greater than 4 bit control for that we use the PIC18f4520.

2.1. Arduino UNO R3

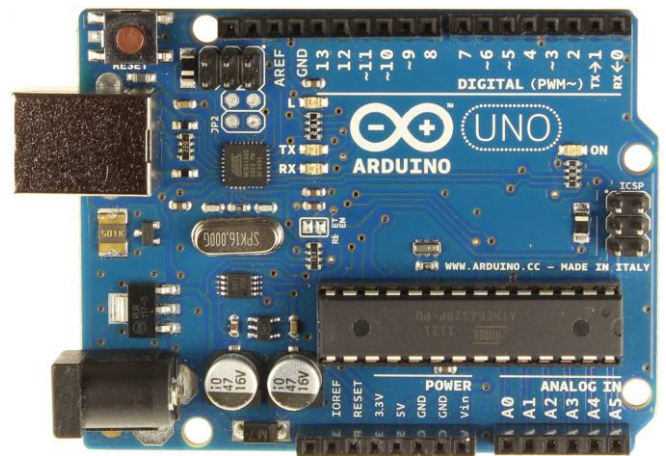

Parameter	Arduino ATmega2560	Arduino uno r3
Operating Voltage	5V	5V
Input Voltage	7-12V	7-12V
Digital I/O Pins	54	14
Analog Input Pins	16	6
Analog Input Pins	256KB	32KB
Cache	16KB L1	32KB L1 and 128KB L2
SRAM	8KB	2KB
EEPROM	4KB	1KB

2.2. Ultrasonic Sensor:



Parameter	Hc-sr04 ultrasonic sensor
power supply	5V
quiescent current	2mA
effectual angle	±15
ranging distance	2cm 500 cm
resolution	0.3 cm

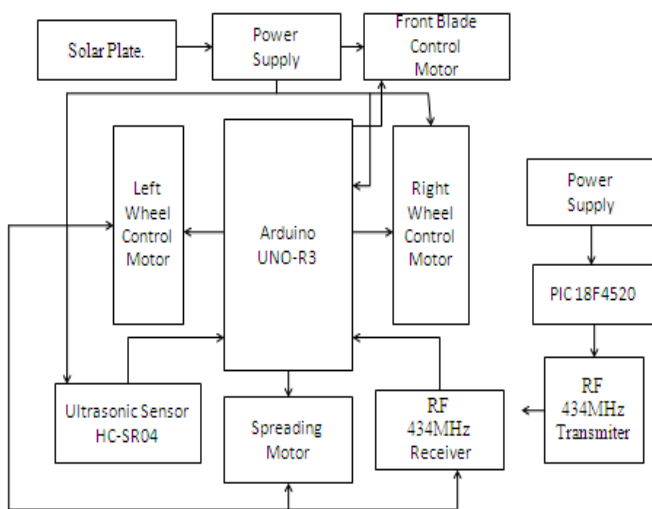

Fig -1: Block Diagram

2.3.RF 434MHz Trance-receiver :



Features of RF module :-

- Operating Frequency -434MHz
- Operating Range-100m(300ft)
- Operating Voltage-5V

2.4 .Water pump:-



- Operating voltage 12v
- Current-0.1A-0.5A
- Lift-130cm
- Flow Rte-300L/H

2.5.Grass Cutter Motor:-



Flow Chart:-

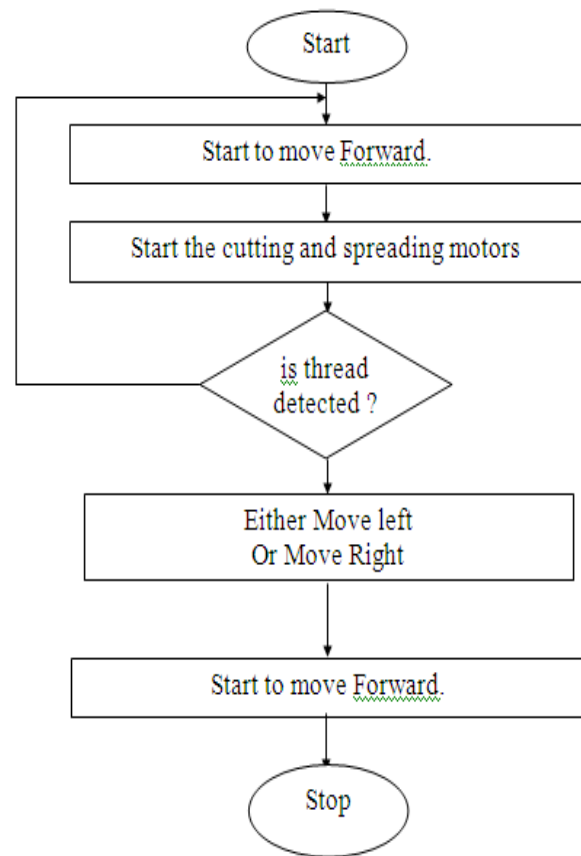

4. CONCLUSION

By doing this project we conclude that ,we can reduce the human efforts and this will be helpful for farmer . As it is operated on solar energy so the it is best application that dose not affects on environment.



5. REFERENCES

- [1] Tao Liu, Bin Zhang, Jixing Jia, Electromagnetic navigation system design of the green house spraying robot, IEEE (2014).
- [2]. Gholap Dipak Dattatraya¹, More Vaibhav Mhatardev, Lokhande Manojku-mar Shrihari, Prof. Joshi S.G Robotic Agriculture Machine, International Journal of Innovative Research in Science, Engineering and Technology, Volume 3, Special Issue 4, April 2014.
- [3]. Sajjad Yaghoubi, Negar Ali Akbarzadeh, Shadi Sadeghi Bazargani, Sama Sadeghi Bazargani, Marjan Bamizan, Maryan Irani AS1 , Autonomous Robots for Agricultural tasks and farm assignment and future trends in Agro Robots, IJMME-IJENS Vol.13 No.03(2013).
- [4]. K. Prema, N.Senthil Kumar, S.S.Dash ,Sudhakar Chowdary, Online control of remote operated agricultural Robot using Fuzzy Processor and Virtual Instrumentation, IEEE (2012).
- [5]. John Billingsley, Agricultural Robotics , IEEE Robotics Automation Magazine (2009).