

# High-Power Bidirectional Dual Active Bridge And Double Dual Active Bridge DC-DC Converter

S.Venkatesh<sup>1</sup> , K.Gopiteja<sup>2</sup>, D.Subba rao<sup>3</sup>

<sup>1,2,3</sup>Assistant professor, Department of EEE , KKR & KSR institute of technology & sciences , Guntur, A.P, India

\*\*\*

**Abstract** - Electrical power should be transmitted around the aircraft at a high voltage (HV) with low current and low conduction losses in order to reduce the weight. In this view, dual active bridge converter is found to be the most reliable configuration for sustaining aircraft operations even under severe supply transients. This converter enables significant energy savings, but requires high-power-density dc-dc converter for a variety of applications such as battery-based uninterrupted power supplies to mission critical aerospace applications, e.g., actuators and avionics. The dual active bridge (DAB) topology for dc-dc conversion has been popular due to its high performance, high efficiency, galvanic isolation, and inherent soft-switching property. These features make the DAB dc-dc converter suitable for high-power-density aerospace applications. Bidirectional power flow capability is a key feature of DAB dc-dc converters, permitting flexible interfacing to energy storage devices. Trapezoidal and triangular modulation methods achieve triangular and trapezoidal currents in the DAB converter ac link. Simulation and performance evaluation of the DAB and double dual active bridge converter shown in which can act as an interface between energy storage devices such as an ultracapacitor bank and the aircraft electrical power network. Ultracapacitors constitute one form of energy storage device, which can be used to meet transient power demands and smooth the load on the generators. Prototype and its results of dual active bridge converter is presented.

**Key Words** : DC-DC converter, Dual active bridge (DAB), Double DAB , Snubber capacitor, zero-voltage switching (ZVS).

## I. INTRODUCTION

A DC-to-DC converter is an electronic circuit which converts a source of DC from one voltage level to another. It is a class of power converter. DC to DC converters are important in portable electronic devices such as cellular phones and laptop computers, which are supplied with power from batteries primarily. Such electronic devices often contain several sub-circuits, each with its own voltage level requirement different from that supplied by the battery or an external supply (sometimes higher or lower than the supply voltage). Additionally, the battery voltage declines as its stored energy is drained. Switched DC to DC converters offer a method to increase voltage from a partially lowered

battery voltage thereby saving space instead of using multiple batteries to accomplish the same thing.

Future aircraft are likely to employ electrically powered actuators for adjusting flight control surfaces and other high-power transient loads. To meet the peak power demands of aircraft electric loads and to absorb regenerated power, an ultracapacitor based energy storage system is examined in which a bidirectional DAB dc-dc converter is used [1]. By using dual active bridge (DAB) topology for dc-dc conversion has been popular among researchers over the past two decades due to its high performance, high efficiency, galvanic isolation, and inherent soft-switching property. These features make the DAB dc-dc converter a strong candidate for high & low-power-density aerospace applications[2].

The DAB topology is considered the most promising for high power, high-density and isolated applications where bidirectional power flow is required[3]. Transformer-based converters may provide isolation between the input and the output. ZVS condition for these switches can be achieved easily. The switches of another leg in the output bridge turn off alternately under ZCS condition when the transformer current reaches zero. Thus, the total input power is transferred to the load and there is no circulation energy flowing back from output in the circuit[4]. RCD snubber losses appeared in the basic circuit topology are drastically reduced by ZCS/ZVS operation with the assistance of newly added active clamp circuit, as well as ZVS operation with lossless snubber capacitor in high-voltage primary side[5]. In [6], Inoue and Akagi validated DAB performance for next-generation power conversion systems using ultracapacitor-based technologies. Although the DAB converter has an inherent soft-switching attribute, it is limited to a reduced operating range depending on voltage conversion ratio and output current. This is a drawback for applications that operate mainly with variable or low loads as the overall converter efficiency is reduced. This was achieved by modulating the duty cycle of the converter bridge to reduce losses over a wide operating voltage range.

## II. Dual active bridge (DAB)

The dual active bridge is a bidirectional, controllable, dc-dc converter that has high power capabilities comprised of eight semiconductor devices, a high frequency transformer, energy transfer inductor, and DC-link

capacitors. The converter can be more simply described as a more common full-bridge with a controllable rectifier. Due to the symmetry of this converter, with identical primary and secondary bridges, it is capable of bidirectional power flow control and the reason why it is selected for the smart green power node application. The topology is shown in Figure1, where are the dc-link voltages, is the leakage inductance of the transformer plus any necessary external energy transfer inductance, and the controllable semiconductor switches.

The dual active bridge has been studied extensively previously in similar applications. In previous years, in order to accommodate high dc-link voltages (>300V), insulated gate bipolar transistors (IGBTs) have been common place. As such, 1–8 switching cells have been traditionally implemented with anti parallel diodes and snubber capacitors in order to direct current commutation on switching events and to allow for zero voltage switching (ZVS) through the snubber capacitor and energy transfer inductance resonance.

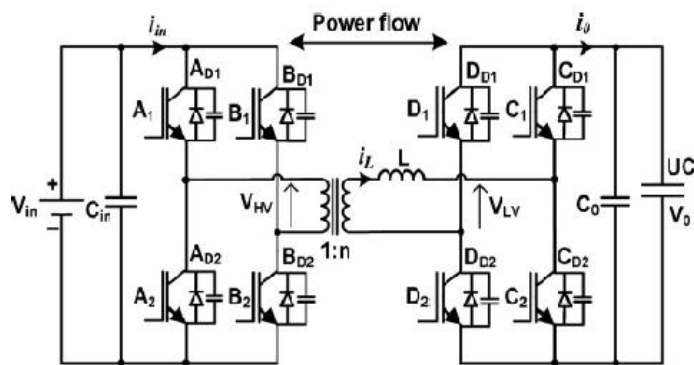

Fig. 1. Schematic of the DAB dc-dc converter.

**Basic Principle of Operation**

Future aircraft are likely to employ electrically powered actuators for adjusting flight control surfaces and other high-power transient loads [1]. To meet the peak power demands of aircraft electric loads and to absorb regenerated power, an ultra capacitor based energy storage system is examined in which a bidirectional DAB dc-dc converter is used. The DAB converter shown in figure 1 consists of two full-bridge circuits connected through an isolation transformer and a coupling inductor *L*, which may be provided partly or entirely by the transformer leakage inductance.

The full bridge on the left hand side of Figure 1 is connected to the HV dc bus and the full bridge on the right-hand side is connected to the low-voltage (LV) ultra capacitor. Each bridge is controlled to generate an HF square-wave voltage at its terminals. By incorporating an appropriate value of coupling inductance, the two square-waves can be suitably phase shifted with respect to each other to control power

flow from one dc source to another. Thus, bidirectional power flow is enabled through a small light weight HF transformer and inductor combination, and power flows from the bridge generating the leading square-wave. Although various modes of operation of the DAB converter have been presented recently for high-power operation, the square wave mode is supposedly the best operating mode. This is because imposing quasi-square-wave on the transformer primary and secondary voltages results in trapezoidal, triangular, and sinusoidal waveforms of inductor current in the DAB converter ac link. These modes are beneficial for extending the low-power operating range of the converter. Although these modes tend to reduce the switching losses, the voltage loss is significant due to zero voltage periods in the quasi-square wave, which reduces the effective power transfer at high-power levels.

**Snubber capacitor**

Snubbers are energy- absorbing circuits used to suppress the voltage spikes caused by the circuit's inductance when a switch, electrical or mechanical, opens. The most common snubber circuit is a capacitor and resistor connected in series across the switch (transistor).

**Zero-voltage switching (ZVS)**

Soft switching (ZVS) can best be defined as conventional PWM power conversion during the MOSFET's on-time but with resonant switching transitions. The technique can be considered PWM power utilizing a constant off-time control which varies the conversion frequency, or on-time to maintain regulation of the output voltage. For a given unit of time, this method is similar to fixed-frequency conversion. Regulation of the output voltage is achieved by adjusting the effective duty cycle (and thus on-time), by varying the conversion frequency. During the ZVS switch off-time, the regulator's L-C circuit resonates traversing the voltage across the switch from zero to its peak and back down again to zero when the switch can be reactivated, and lossless ZVS facilitated. Two other advantages of ZVS are that it reduces the harmonic spectrum of any EMI (centering it on the switching frequency) and allows higher frequency operation resulting in reduced, easier-to-filter noise and the use of smaller filter components.

Moreover, ZVS technology allows the use of switches with lower-voltage ratings, because there is no transient overvoltage, and the reverse voltage applied to the primary switches is limited to the peak input voltage, at most.

**ZVS LIMITS**

During transistor turn-OFF, resonance will naturally occur between device output capacitance and coupling inductance. The energy stored in the coupling inductance is sufficient to ensure charge/discharge of device output capacitances at the switching instants. The converter

operating conditions to achieve virtually loss-less ZVS conditions are:

- 1) at turn-ON of any device, its anti parallel diode is conducting;
- 2) at turn-OFF of any device, the minimum current flow through the device is positive.

### III. DOUBLE DUAL ACTIVE BRIDGE CONVERTER

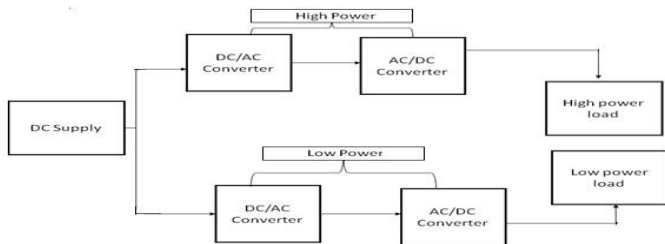

Fig., 3: Block diagram of dc-dc converter for high & low power application

Two separate DAB is used for high power and low power load as shown in the fig 3. In high power DAB , IGBT is used as large IGBT modules typically consist of many devices in parallel and can have very high current handling capabilities in the order of hundreds of amperes with blocking voltages of 6000 V, equating to hundreds of kilowatts. In lower DAB, MOSFET is used as the power MOSFET is the most widely used low-voltage (that is, less than 200 V) switch.

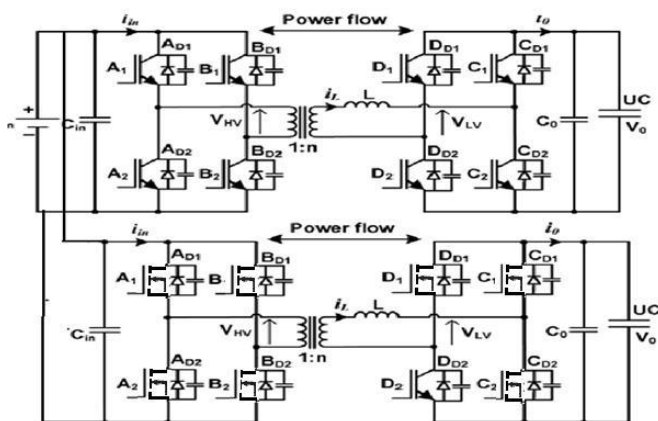

Fig., 4 Double DAB Bridge Circuit diagram

### POWER STAGE TOPOLOGY AND OPERATION PRINCIPLE:

The double DAB converter shown in Fig.4 consists of two full-bridge circuits connected through an isolation transformer and a coupling inductor L, which maybe provided partly or entirely by the transformer leakage inductance. The full bridge on the left hand side of Fig.4 is connected to the HV dc bus and the full bridge on the right

hand side is connected to the low-voltage (LV) ultra capacitor. Each bridge is controlled to generate an HF square-wave voltage at its terminals. By incorporating an appropriate value of coupling inductance, the two square-waves can be suitably phase shifted with respect to each other to control power flow from one dc source to another.

Thus, bidirectional power flow is enabled through a small lightweight HF transformer and inductor combination, and power flows from the bridge generating the leading square-wave. Although various modes of operation of the DAB converter have been presented recently for high power operation, the square-wave mode is supposedly the best operating mode. This is because imposing quasi-square-wave on the transformer primary and secondary voltages results in trapezoidal, triangular, and sinusoidal waveforms of inductor current in the DAB converter ac link. These modes are beneficial for extending the low-power operating range of the converter. Although these modes tend to reduce the switching losses, the voltage loss is significant due to zero voltage periods in the quasi-square-wave, which reduces the effective power transfer at high-power levels.

### IV. SIMULATION RESULTS

#### Bidirectional dual active bridge dc-dc converter in forward operation mode:

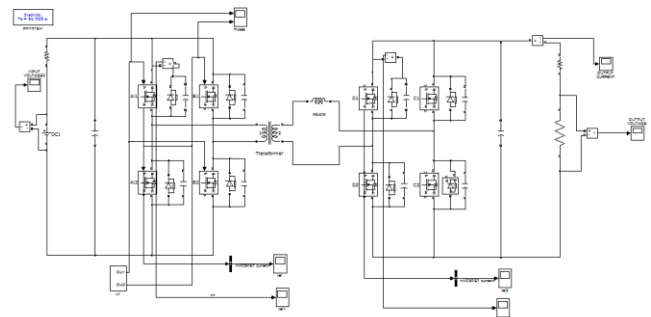

Fig. 5.1 Simulink model of bidirectional dual active bridge dc-dc converter in forward operation mode.

In the above simulink, the input side is called LV side and the output side is called HV side. in forward operation mode the mosfets on LV side are triggered by using pulse generator and the diodes are reverse biased. And mosfets in the HV side are not triggered and kept switched off and the diodes are in forward bias so that it works as a rectifier and finally the dc output is obtained as the transformer is having 1: n winding ratio the voltage from LV side is boosted and converted in to dc output as shown in the figure6.1 the output wave forms are as follows:

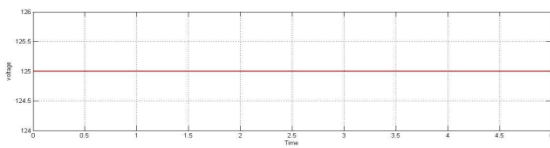

Fig 5.2: Simulation input voltage wave form

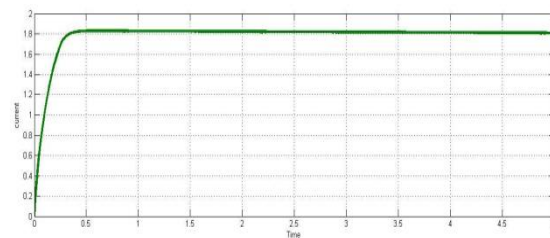

Fig. 5.3: Output current in forward operation .

The output current wave form of the converter in forward mode of operation which is of about 1.8A is shown in figure 5.3

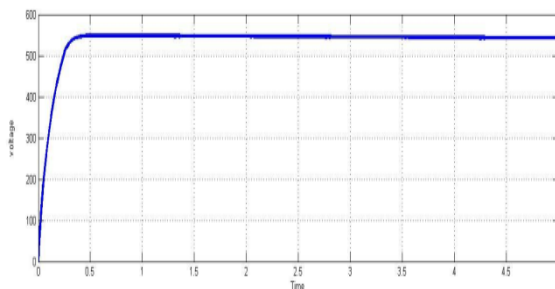

Fig.5.4: Output voltage wave form in forward operation

The output voltage waveform of the converter when operated in forward mode which is of about 540V is shown in figure 5.4

**Bidirectional dual active bridge dc-dc converter in Reverse operation mode:**

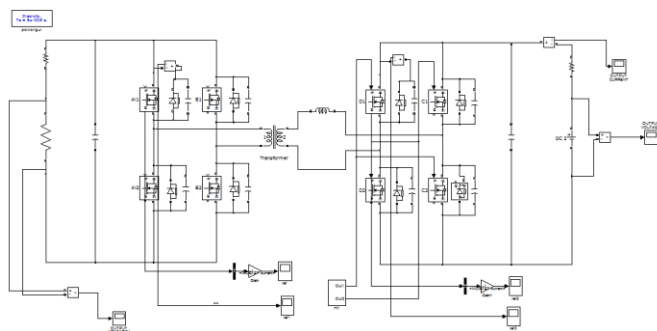

Fig. 5.5 Simulink model of bidirectional dual active bridge dc-dc converter in reverse operation mode.

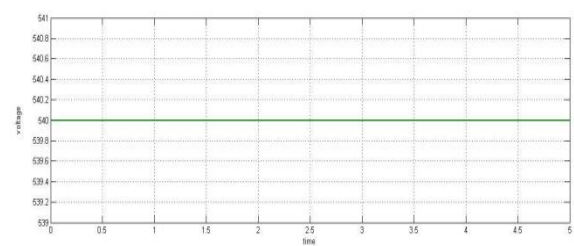

Fig 5.6: Input voltage wave form

In reverse mode the input is given at the HV side of the converter which is reverse mode of operation which is about 540V.

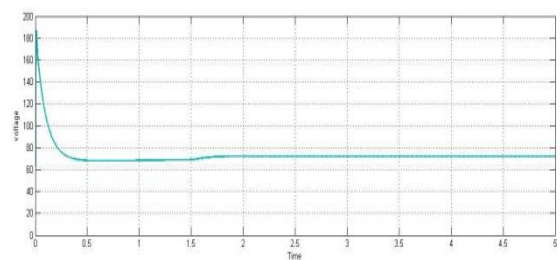

Fig.5.7: Output voltage wave form in reverse operation

The output voltage waveform of the converter when operated in reverse mode which is of about 540V is shown in figure 5.7.

**V. HARDWARE / PROTOTYPE RESULTS**

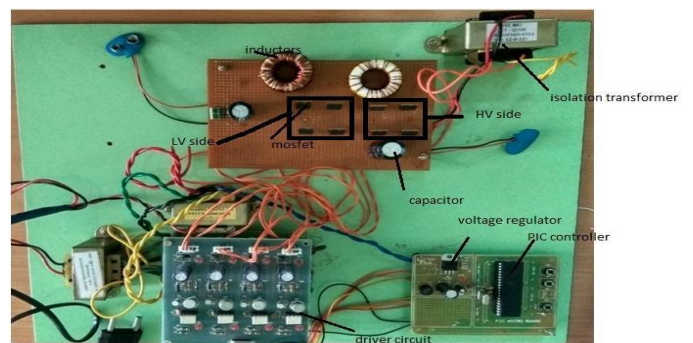

Fig 6.1 Photograph of the DAB dc-dc converter prototype.

The above circuit is the prototype which has the PIC controller for getting the pulses and the driver circuit for amplification since the mosfet needs 9v to 12v for getting turn ON and mosfets for switching and also contains an isolation transformer for stepping up and stepping down the voltage in forward and reverse modes of operation respectively.

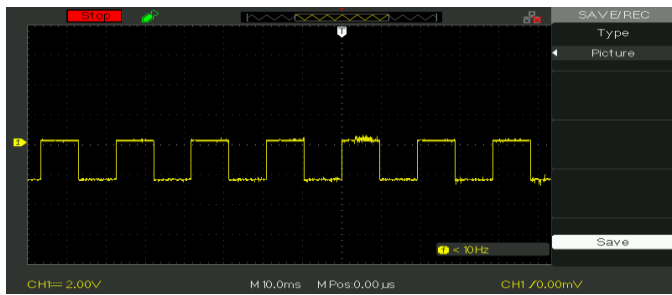

Figure 6.2 : Pulses from PIC micro controller

The wave form shown in figure 6.2 is the pulses from the pic controller which are of 5V and these pulses are needed to be amplified.

**Output wave forms in forward (boost) mode:**

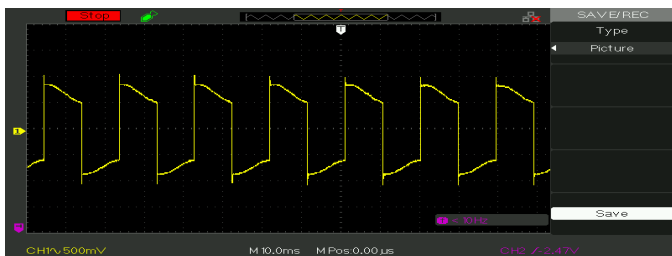

Figure 6.3: Voltage across the MOSFET

Here the wave form shown in figure 6.3 is the voltage across the Mosfet i.e from drain to source in this the voltage rises suddenly to the peak and reduces slowly .

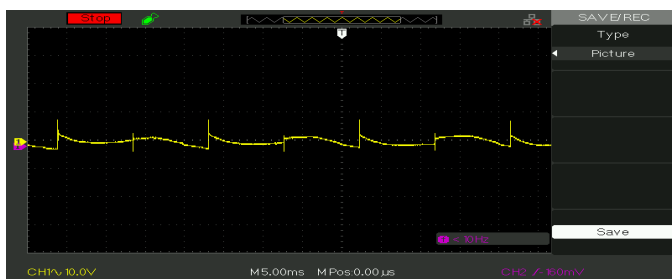

Figure 6.4: diode voltage

As the Mosfet IRFP250N consists of an inbuilt diode the above shown in figure 6.4 is wave form of voltage across the diode on HV side in forward mode of operation.

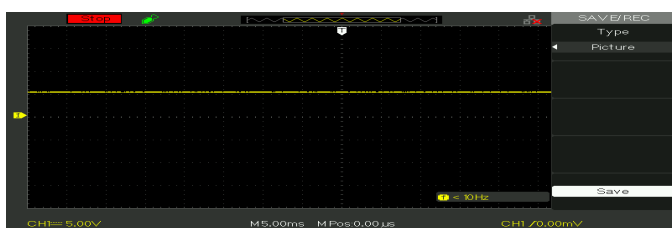

Figure 6.5: Input voltage

This is the input voltage given to the circuit from an ordinary battery of 9V in forward mode of operation as shown in figure 6.5.

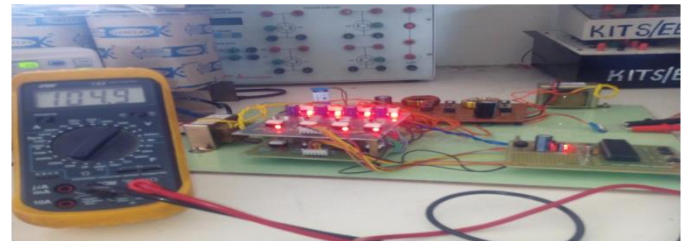

Figure 6.6: Forward output voltage

The waveform shown in figure 6.6 is the output voltage in the forward mode of operation which is generally boost mode of operation and the obtained voltage is 104.9V.

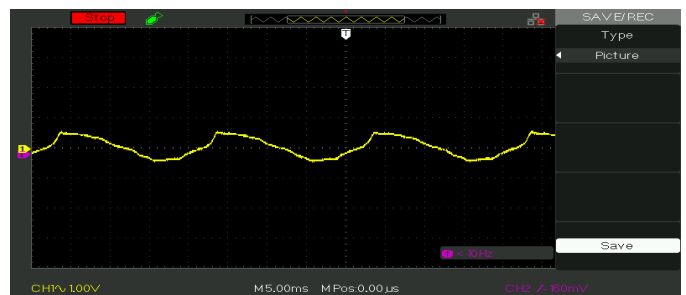

Figure 6.7: voltage across MOSFET in reverse mode

The waveform shown in figure 6.7 is the voltage across the MOSFET which is on HV side of the converter and this will gradually rise and falls suddenly as shown above.

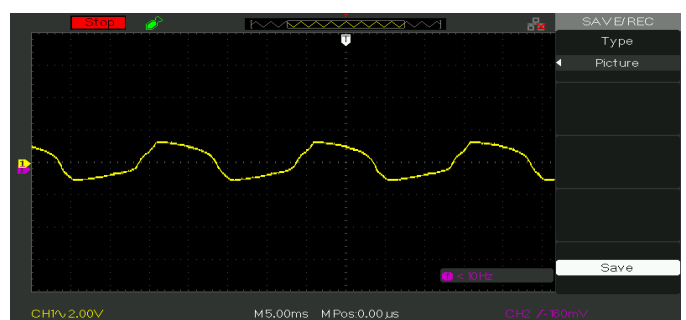

Figure 6.8: LV side diode voltage

As the mosfet IRFP250N consists of an inbuilt diode the above shown wave form is the voltage across the diode on LV side in reverse mode of operation.

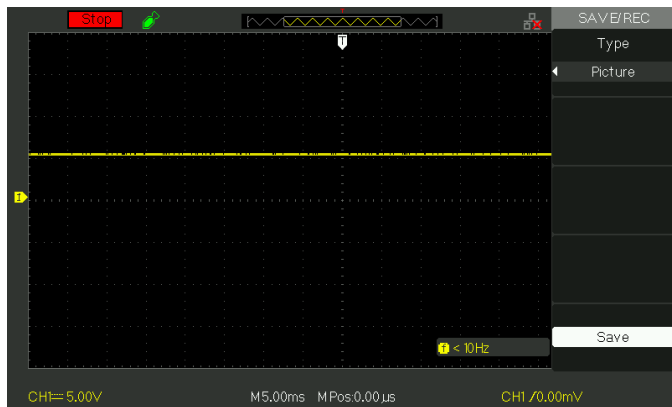

Figure 6.9: Input voltage in reverse (buck) mode

The waveform shown in figure 6.9 is the input voltage of the converter in reverse mode of operation i.e on HV side of the converter which is of 9V battery.

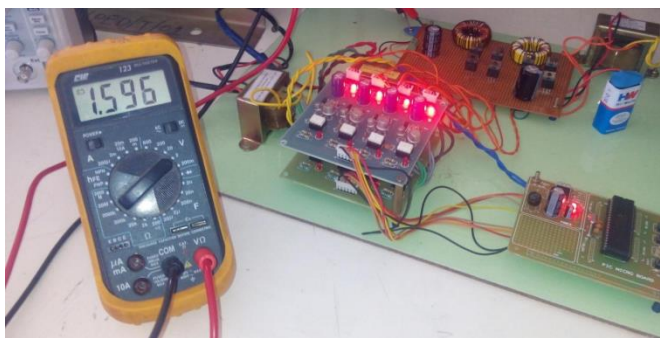

Figure 6.10: output voltage in reverse (buck) mode

## VI. CONCLUSION

A dual active bridge and double dual active bridge dc-dc converter simulation and hardware of high power dc-dc converter is presented. The square-wave operating mode of DAB is the best mode for high-power transfer. These proposed system useful in predicting losses that occur in the devices and passive components and enable a study of the converter characteristics. The operation of the DAB dc-dc converter has been verified through extensive simulations which, in turn, confirm the accuracy of the model. The experimental results confirm that provision of snubber capacitors across the IGBTs reduces switching losses and device stresses and improves the converter performance.

## REFERENCES

[1] R. T. Naayagi, *Member, IEEE*, Andrew J. Forsyth, *Senior Member, IEEE*, and R. Shuttleworth, *Member, IEEE*. "High-Power Bidirectional DC-DC Converter for Aerospace Applications", *IEEE Transactions on Power Electronics* ( Volume: 27, Issue: 11, Nov. 2012 ).

[2] S.Sheikameer Batcha, Dr.T.Vijaya Kumar, Mr.B.Ram Kumar "A Double Active Bridge Converter for High and Low Power Aerospace Applications" *IJAREEIE* Vol. 4, Issue 4, April 2015.

[3] S. Zhiyu, R. Burgos, D. Boroyevich, and F. Wang, "Soft-switching capability analysis of a dual active bridge dc-dc converter," in *Proc. IEEE Electr. Ship Technol. Symp.*, 2009, pp. 334-339.

[4] J. M. Zhang, D. M. Xu, and Z. Qian, "An improved dual active bridge DC/DC converter," in *Proc. IEEE Power Electron. Spec. Conf.*, Jun. 2001, vol. 1, pp. 232-236.

[5] E. Hiraki, K. Yamamoto, T. Tanaka, and T. Mishima, "An isolated bidirectional DC-DC soft switching converter for super capacitor based energy storage systems," in *Proc. IEEE Power Electron. Spec. Conf.*, Jun. 2007, pp. 390-395.

[6] S. Inoue and H. Akagi, "A bidirectional dc-dc converter for an energy storage system with galvanic isolation," *IEEE Trans. Power Electron.*, vol. 22, no. 6, pp. 2299-2306, Nov. 2007.

## BIOGRAPHY



S.Venkatesh received B.tech (EEE) From jntu, anantapur in the year (2007-2011) and M.tech (Power Electronics) in Narayana Engineering College, Gudur, A.P , India (2012 - 2014). He is currently working as

Assistant Professor in the department of Electrical and Electronics Engineering at KKR&KSR Institute of Technology and Sciences , Guntur Dist, Andhra Pradesh , India. His research areas include Power Electronics and Electric Drives.



K.Gopiteja received B.tech (EEE) From jntu, Kakinada in the year (2006-2010) and M.tech (Control systems) in St.Marys College of engineering and technology, Hyderabad , Telangana , India (2011 - 2013). He is currently working as Assistant Professor in the

department of Electrical and Electronics Engineering at KKR&KSR Institute of Technology and Sciences , Guntur Dist, Andhra Pradesh , India. His research areas include Power Electronics and Control systems.



**D.Subbarao** received the B.Tech degree in Electrical and Electronics Engineering from JNTU University, Hyderabad, India in 2008, and the M.Tech degree in Power Systems Engineering from Acharya Nagarjuna University, India in 2012. He is currently working as Assistant

Professor in the department of Electrical and Electronics Engineering at KKR & KSR Institute of Technology and Sciences, Guntur Dist.,AndhraPradesh,India.

