

Electricity Generation Using Treadmill Tricycle

Abhiram R¹, Afsal Thajudeen², Desarehdh S³, Jishnu V⁴, Nithin Prasad⁵, Anuraj A R⁶

^{1,2,3,4} B Tech Students, Department of Mechanical Engineering, Sree Narayana Institute of Technology, Adoor, Kerala, India

⁵ M Tech Student, Department of Mechanical Engineering, Sree Narayana Institute of Technology, Adoor, Kerala, India

⁶ Asst. Professor, Department of Mechanical Engineering, Sree Narayana Institute of Technology, Adoor, Kerala, India

Abstract - Now a day's exercises play an important role in human life. As we know the exercising will reduce the amount of excess calorie of the body and annihilates the metabolic activities of the body. When doing exercise, a large amount of human energy is get wasted. Our project is mainly aim to convert this energy into sufficient form and for making the exercise more convenient by a new design. For that we designed a tricycle where the pedal of the cycle is fully replaced by a treadmill. The treadmill will drive the rear wheels of the cycle via a chain drive, so that its need only the effort of exercising in treadmill to travel a short distance conveniently. A stand is provided to make the tricycle inclined at stationery state and can be use the tricycle as a perfect treadmill. A powerful dynamo and a battery is provided to the rotating parts of the tricycle so that it can produce and store electrical energy during exercising or travelling. We can use this electrical energy in emergency situations such as power failure, it can light some lamps in a room and can give power for music systems etc.

Key Words: Treadmill, chain drive, dynamo, tricycle.

1. INTRODUCTION

The treadmill tricycle is totally new way of moving it is done by the combination of various mechanical part i.e. chain and gear. Motion of tricycle from one place to another place will be done by human effort. Treadmill tricycle basically shows a new concept for both travelling and exercising. Due to the ever-increasing demand of fuel for various purposes it also eliminates the use of any fuel in any case. The gears present in it provide us the speed which is required for travelling faster. This makes this tricycle different from a simple bicycle.

A treadmill is a device used for exercises by staying in the same place, walking or running can be done on it. From the principle of treadmill working integrated with the principle of electromagnetic induction, a new tricycle is designed which is capable of generating electric power while exercising. The most striking feature of this design is that it can be made possible as a mobile and power generating treadmill.

The walking cycle has a simple mechanism, operated with free wheels, gear chain, bearing shaft and

links arrangement. As the straight line motion during walking gets converted to rotary motion through very simple movement by means of a gear chain and free wheel mechanism of the linkages. The rotary motion is again converted in to linear motion of the cycle through gear chain and free wheels arrangement. The conveyor system is either continuous movement or intermittent which is completely based on the person. This invention relates to improvements in transport devices, and it relates particularly to devices for transferring people, with small in number in case of a bike or a cycle.

The Walking Bicycle is the one, which combines walking and cycling into one activity. This combines the two activities into a straight line motion simply by walking on the belt provided, allowing to propel forward at desirable speed. Usually, the operation of the walking cycle machine is controlled by the user itself by simply walking on the treadmill belt and also balancing the cycle. The operating speed of the walking cycle differs on the amount of force applied by the user.

2. TRICYCLE

A tricycle (trike) is a human-powered three-wheeled vehicle. Some tricycles were used for commercial purposes in the developing countries. Tricycles are favored because of their apparent stability than a bicycle, but a conventional trike shows poor dynamic lateral stability and because of that, the rider must take care when cornering to avoid tipping it over.

A three wheeled wheelchair was introduced by German man Stephan Farffler in 1655 or 1680 to maintain his mobility. Since he was a watch-maker, he was able to create a vehicle that was powered by hand cranks [6]. Later in 1789, a three-wheeled vehicle powered by pedals was developed by two French inventors and called it as tricycle. In 1818, British inventor Denis Johnson patented his approach to designing tricycles. In 1876, James Starley developed the Coventry Lever Tricycle, having two small wheels on the right side along with a large drive wheel on the left side and power was provided by using hand levers. In 1877, he developed a Coventry Rotary, one of the first rotary chain drive tricycles. In 1881, the Leicester Safety Tricycle Company of England introduced the first front steering tricycle costs £18. They

also developed folding tricycles at the same time. Riders prefer tricycles because of the uncomfortable feel on the high wheelers.

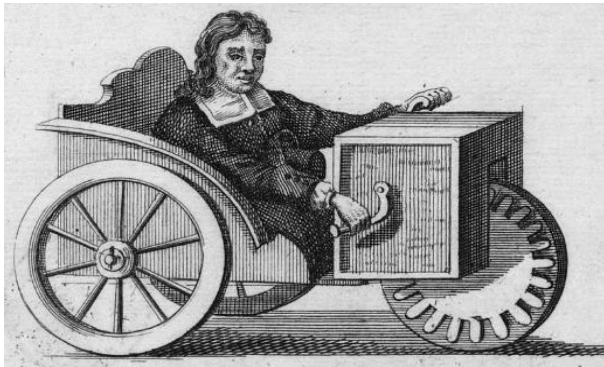

Fig -1: Stephan Farffler's hand-controlled three-wheeled wheelchair



Fig -2: Modern upright tricycle

3. METHODOLOGY

3.1 Working

The treadmill tricycle working on the basis of energy conversion. When a man is exercising on a treadmill his effort is gets wasted. But in this treadmill tricycle, the human effort is converted as useful work. Travelling and exercising can be done at a time. The conveyor is driven by manually. The main roller is fixed on the rear side and a helical driver gear is fitted to the roller. When the conveyor moves by leg power which will rotates the roller and the helical gear attached to the roller also rotates. Another shaft is fitted with a driven helical gear is then attached to the main helical gear. A sprocket is fixed on the second shaft will give drive to the rear wheels via chain drive. Rear wheel assembly will support and stabilize the arrangement.

3.2 Electricity Generation

To harness the power of animals or humans for doing work, treadmills were introduced, which are a type of mill operated by a person or animal treading steps of a tread-wheel to grind grain [2]. Treadmills are not used to harness power nowadays, but used as an exercise machines

for running or walking. The machine provides a moving platform with a wide conveyor belt (track) rather than the user powering the mill and was driven by an electric motor. This simple, light and low budget treadmills passively resist the motion, moves only when walkers push the belt with their feet. But an addition of small DC generators were done, whose moving parts are mechanically coupled with the moving rollers of machine that moves when belt of the treadmill is moving. When the rotor of the DC generator starts moving, an emf will be produced across its output terminals. This generated emf can be used for charging of Battery or other purposes.

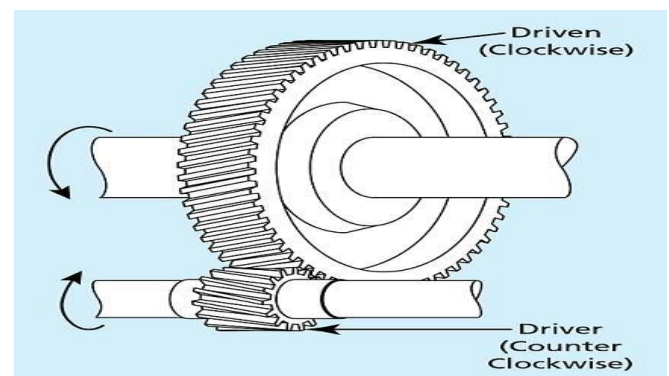

Fig -3: Gear coupling for driving mechanism

In a bicycle generator, a small dc generator is attached to one of the wheel of the bicycle. When the bicycle runs, the rotor which is attached to the cycle wheel also rotates and emf will be generated across the output terminals of the generator. This emf is then generally used for lighting the head-light of the bicycle.

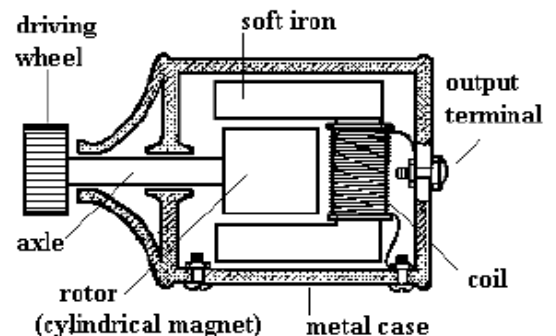

Fig -4: Bicycle generator (12V,6W)

3.3 Working Principle

The bicycle generator is small and a low torque is required to rotate its rotor. Here in the treadmill, instead of using one single large generator a number of small generators is used [9], which are electrically parallel connected and mechanically roller coupled.

In a treadmill, the belt moves on some cylindrical shape of rollers and those rollers are surrounded by the belt

in both upper and lower sides. Each join side (left and right) of the roller is mechanically coupled with the rotor of a small DC generator such that as the roller rotates, the rotor also starts to rotate.

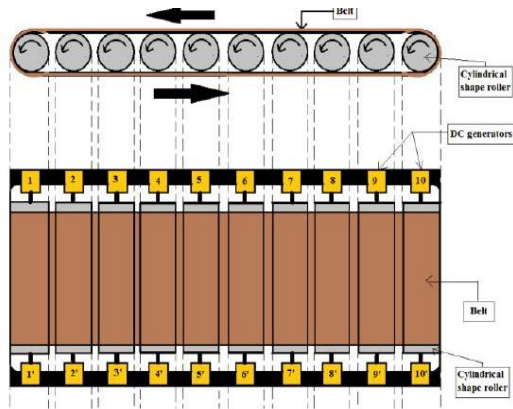

Fig -5: Basic diagram of mechanical arrangement of treadmill

3.3.1 Electrical Connection of DC Generators in Treadmill Platform

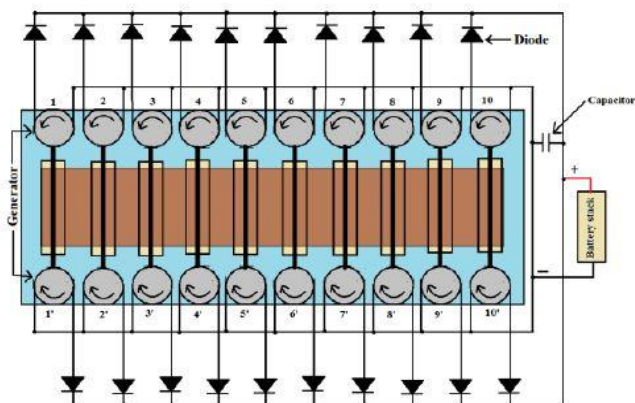

Fig -6: Electrical connection of dc generators in treadmill

The electrical connection of the treadmill is shown in the Fig.6. Electrically these generators are connected in parallel with each other, but the rotor of each DC generator is rotating in opposite direction with respect to them.

The DC generators 1, 2, 3, etc. are rotating in opposite direction with respect to the direction of the rotation of DC generators 1', 2', 3, etc. So, the emfs generated by them is also in 180° out of phase with respect to the other generator, situated in opposite side of the roller. To eliminate this problem, 1, 2, 3 etc. should be connected parallel to the opposite terminals of 1', 2', 3' etc. Also a diode should be connected with the positive terminals of each DC generators. This will prevent them to work as a motor as they are mainly connected to the battery and their main

work is to charge the battery not to take energy from it. If for any reason the belt of the treadmill is running in opposite direction then these diodes will prevent the current to circulate in opposite direction. There is also a capacitor connected across the output terminals (Fig.6) to prevent the fluctuations of the DC output voltage and keep it steady-state or at a constant value.



Fig -7: Direction of the forces acting on the treadmill

In the above figure, the force (F_{total}) is applied on the track (or belt) of treadmill by the runner can be divided into two components, one is vertical component (F_v) and another is the horizontal component (F_h).

$$F_{total} = F_v + F_h \tag{1}$$

Only the horizontal component of the applied force (F_h) is responsible for moving the treadmill's belt. Now, the average speed of jogging for a normal man is 10 km/h. So, if someone runs with that speed then the belt of the treadmill also runs with that speed. The dimension of a normal treadmill is shown as follows.

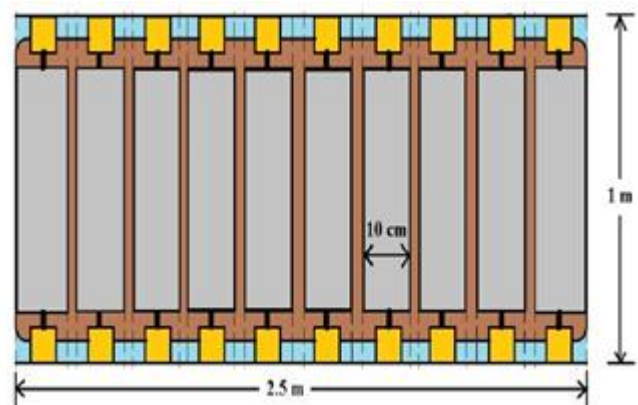

Fig -8: Dimension of a treadmill

From the above diagram, it is shown that the length of the belt is = $(2 * 2.5 \text{ m}) = 5 \text{ m}$ (As the belt is surrounded the rollers in both upper and lower sides). So, for one full rotation of the belt a man has to run 5m. If a man running at a speed 10 km/h then in one hour the belt rotates = $(10 * 10^3) / 5 = 2000$ times. So, the speed of the belt rotation is 2000 r.p.h or, $(2000/60) = 33 \text{ r.p.m}$. Here, the diameter of

each roller is = 10 cm. So, for each rotation of the belt one roller completes = $(5 * 10^2) / (\text{pie} * 10) = 16$ full rotation. Here, the DC generator's rotors are coupled with the rollers. So, each generator completes 16 full rotation with one full rotation of the belt. So, the speed of each DC generator = $(16 * 33)$ r.p.m. = 528 r.p.m.

This speed is enough to generate 6 W electric power for each DC generator at 12V (output voltage). Here, in the above arrangement of the treadmill we assume ten rollers which are surrounded by the belt. With each roller two DC generators are mechanically connected or coupled. So, the total number of DC generators is = $(2 * 10) = 20$. Thus, the total power generating capacity of this system is = $(20 * 6) = 120$ W. If one man run on this treadmill (with average speed of 10 km/h) for one hour then the total electrical energy produced by this system is = $(120 * 1) = 120$ Watt-hour. Now, this energy can be stored in rechargeable DC batteries. Once the batteries are charged then we can use this energy for lighting or other purposes. The efficiency of the whole system is varying from 80% to 90%. Let, we see some of its applications. Suppose we have a 10 Watt LED bulb, then we can be lighting this bulb by directly connecting it with battery (or with chopper circuit if needed to adjust the DC voltage at rated value) for $(120 / 10) * 0.85 = 10.2$ hours (taking efficiency 85%). We can also be lighting a 40 Watt tube light (with suitable inverter circuit) for 3 to 4 hours. Special type of inverter circuit by which we can directly lighting 40 Watt tube-light without any choke and starter arrangement. Here we can use this inverter circuit for lighting tube-light.

also eliminates the use of any fuel in any case. The gears present in it provide us the speed which is required for travelling faster. This makes this bicycle different from a simple bicycle. With less effort, we can drive through a long way. A treadmill is a device generally for walking or running while staying in the same place.

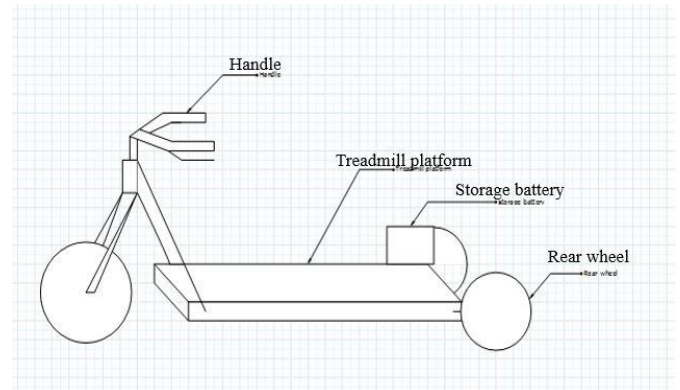

Fig -10: Mechanical layout of treadmill tricycle

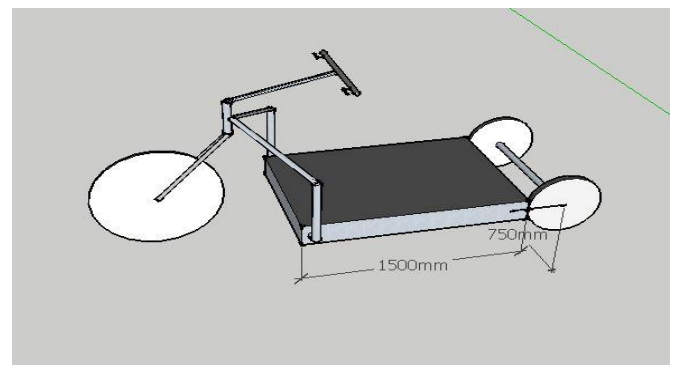

Fig -11: Design of treadmill tricycle

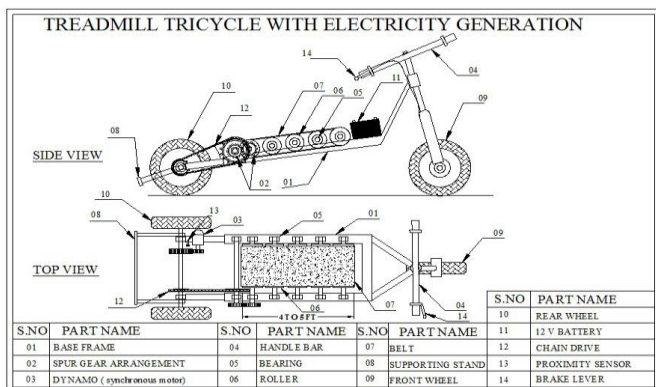

Fig -9: Drawing of treadmill tricycle for electricity generation

4. TREADMILL TRICYCLE

The treadmill tricycle is totally new way of moving it is done by the combination of various mechanical part i.e. chain and gear. Motion of tricycle from one place to another place will be done by human effort. Treadmill tricycle basically a new concept for travelling and exercising. It eliminates most of the issues related to both. As we know how important exercise is in this stress full world so it helps to maintain our health as it works through human effort. Due to the ever-increasing demand of fuel for various purposes it

4.1 Factors Determining Material Choice

4.1.1 Properties

The material selected must possess the necessary properties for the proposed application. Weight, surface finish, rigidity, ability to withstand environmental attack from chemicals, service life, reliability etc. are the various requirements needed to be satisfied. The following four types of principle properties of materials decisively affect their selection

- a. Physical
- b. Mechanical
- c. From manufacturing point of view
- d. Chemical

The various physical properties concerned are melting point, thermal Conductivity, specific heat, coefficient of thermal expansion, specific gravity, electrical conductivity, magnetic purposes etc. The various Mechanical properties Concerned are strength in tensile, Compressive shear, bending, torsional and buckling load, fatigue resistance,

impact resistance, elastic limit, endurance limit, and modulus of elasticity, hardness, wear resistance and sliding properties. The various properties concerned from the manufacturing point of view are,

- Cast ability
- Weld ability
- Surface properties
- Shrinkage
- Deep drawing etc.

4.1.2 Manufacturing case

Sometimes the demand for lowest possible manufacturing cost or surface qualities obtainable by the application of suitable coating substances may demand the use of special materials.

4.1.3 Quality Required

This generally affects the manufacturing process and ultimately the material. For example, it would never be desirable to go casting of a less number of components which can be fabricated much more economically by welding or hand forging the steel.

4.1.4 Availability of Material

Some materials may be scarce or in short supply. It then becomes obligatory for the designer to use some other material which though may not be a perfect substitute for the material designed. The delivery of materials and the delivery date of product should also be kept in mind.

4.1.5 Space consideration

Sometimes high strength materials have to be selected because the forces involved are high and space limitations are there.

4.1.6 Cost

As in any other problem, in selection of material the cost of material plays an important part and should not be ignored.

Sometimes factors like scrap utilization, appearance, and non-maintenance of the designed part are involved in the selection of proper materials.

5. CONSTRUCTION

Treadmill tricycle consist of three wheeled arrangement mounted on an MS frame of length 1.5metre and of width 0.75metre. Human effort is converted as mechanical movement for the tricycle. The driving mechanism consist of a treadmill platform where the conveyor of treadmill supported on number of galvanized steel rollers of diameter 10cm mounted on the frame. Rear two wheels are smaller than front wheel. A steel handle is provided for controlling the direction and to give support for the man travelling on the tricycle. A gear coupling is provided for changing the horizontal motion of the treadmill mat into the rotary motion of rear wheels (i.e., clockwise rotation of then rollers is converted to anticlockwise rotation

for wheels). This is done by means of a chain, sprocket and gear coupling arrangement on the rear portion. 12 V 6 W DC generators and a 12 V storage battery is provided for the electricity generation and storage.

We are using DFM for our paper. Design for manufacturability also known as design for manufacturing. The engineering art of product designing in a way to manufacture easily is the DFM. The concept exists in almost all engineering fields. Depending on the manufacturing technology, the application differs widely. DFM describes the process of product design for facilitating the manufacturing process and reducing its manufacturing costs. In DFM, the potential problems are fixed in the design phase which is the least expensive place to address them. Other factors which may affect the manufacturability are: type of raw material, the form of the raw material, dimensional tolerances, and secondary processing such as finishing.

5.1 Spur Gear

The simplest and most common type of gear used are generally Spur gears having a cylindrical or disk form. The teeth project radially that the leads edges of the teeth to align parallel to the axis of rotation along with these straight-cut gears. They can only mesh accurately if they are attached to parallel axes. The torque ratio can be determined by considering the force that a tooth of one gear exerts on a tooth of the other gear. The force will have both a radial and a circumferential component.



Fig -12: Spur Gear

A gear is component within a transmission device. Transmit rotational force to another gear or device. Meshing allows the force to transfer fully without any slip. Geared devices transmit forces at various speeds, torques or in different direction from the power source based on its construction and arrangement.

5.2 Bearing

A bearing is a device to permit constrained relative motion between two parts, typically rotation or linear movement. Sliding bearings, rolling-element bearings, jewel bearings, fluid bearings and flexure bearings are different types of bearings. Bearings vary greatly over the forces and speeds that they can support. Forces can be radial, axial (thrust bearings) or moments perpendicular to the main axis. Bearings involve some degree of relative movement between surfaces, and different types have limits as to the

maximum relative surface speeds they can handle, and this can be specified as a speed in ft/s or m/s. The moving parts there is considerable overlap between capabilities, but plain bearings can generally handle the lowest speeds while rolling element bearings are faster, hydrostatic bearings faster still, followed by gas bearings and finally magnetic bearings which have no known upper speed limit.



Fig -13: Ball Bearing

5.3 Chain Drive

Chain drive is used for transmitting mechanical power from one place to another. It is used to convey power to the wheels of a vehicle and also used in a wide machine range besides vehicles. The power is conveyed by passing over a sprocket gear with gear teeth meshing with the holes in the chain links. The gear is turned, and this pulls the chain putting mechanical force.

CHAIN DRIVE

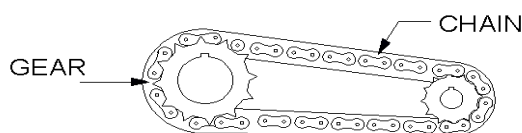

Fig -14: Chain Drive

5.4 Wheel

A wheel is a device which facilitates movement or performing labor in machines by rotating on its axis.



Fig -15: Normal Wheel

A wheel together with an axle overcomes friction by facilitating motion by rolling. A moment needs to be applied to the wheel by gravity or by application of external force for rotating the wheels. Mostly used in transport applications.

More generally the term is also used for other circular objects that rotate or turn, such as a Ship's wheel and flywheel.

5.5 Dynamo

Dynamo is an electrical generator. This dynamo produces direct current with the use of a commutator. The dynamo uses rotating coils of wire and magnetic fields to convert mechanical rotation into a pulsing direct electric current. A dynamo consists of a stator and armature that provides a constant magnetic field and turn within that field.

DYNAMO

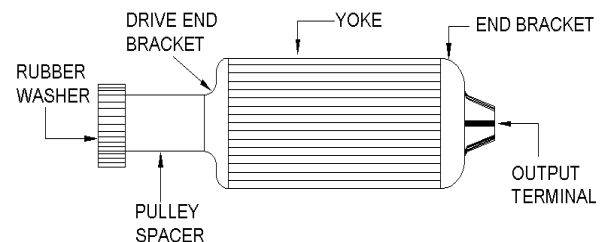
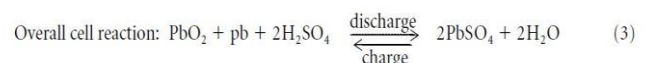
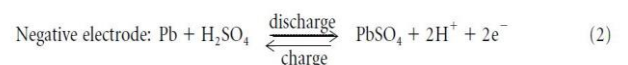
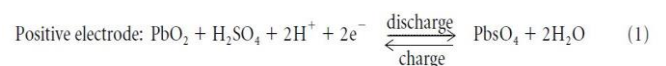

Fig -16: Dynamo

Commutator produces the direct current. When a loop of wire rotates in a magnetic field, the potential induced in it reverses with each half turn, generating an alternating current.

5.6 Battery

Battery is used to store the generated electrical power from the generator. The used battery is sealed Lead-Acid rechargeable battery to meet the specifications of the generator used. The chemical reactions that occur are represented by the following equations:



As the cell is charged, the sulfuric acid (H₂SO₄) concentration increases and becomes highest when the cell is fully charged. Likewise, when the cell is discharged, the acid concentration decreases and becomes most dilute when the cell is fully discharged. The acid concentration is expressed in terms of specific gravity, which is weight of the electrolyte compared to the weight of an equal volume of pure water.

5.7 Drive Shaft

A drive shaft, driveshaft, driving shaft, propeller shaft, or Cardan shaft is a mechanical component for transmitting torque and rotation, usually used to connect

because of the distance of components to allow a relative movement between them. Drive shafts carries torque and incorporate several joints irrespective of distance between the driving and driven components.

6. FABRICATION OPERATIONS

6.1 Arc Welding

Arc welding is a fusion process for joining metals. By applying heat, metal at the joint is melted and caused to weld directly with an intermediate molten filler metal. The final weldment potentially has the same strength properties as the metal of the parts since the joining is an intermixture of metals. This is in sharp contrast to non-fusion processes of joining in which the mechanical and physical properties of the base materials cannot be duplicated at the joint.

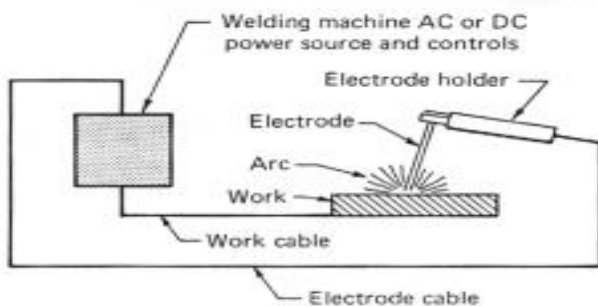

Fig -17: Arc welding

High heat required to melt the metal is produced in arc welding by using an electric arc. The arc formed between work and electrode is manually or mechanically guided along the joint. The electrode is used for carrying the current between tip and work.

6.2 Brazing

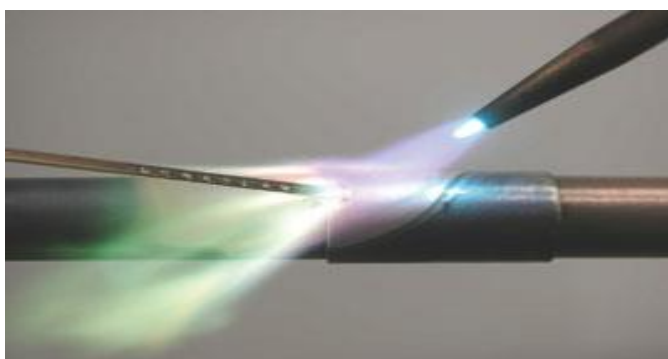

Fig -18: Brazing Operation

Brazing is done when two or more metal items needed to join together, by means of melting and flowing a filler metal into the joint. The filler flows into the gap between parts by means of capillary action. The filler heated to form the flux that flows over the base metal and condensed to join the work pieces together. A major

advantage of brazing is the ability to join the same or different metals with considerable strength.

6.3 Turning

In turning operation, cutting tool follows more or less straight line path as the work piece rotates. During turning, metal piece is rotated and a cutting tool is traversed along 1, 2, or 3 axes of motion to produce accurate diameters and depths.

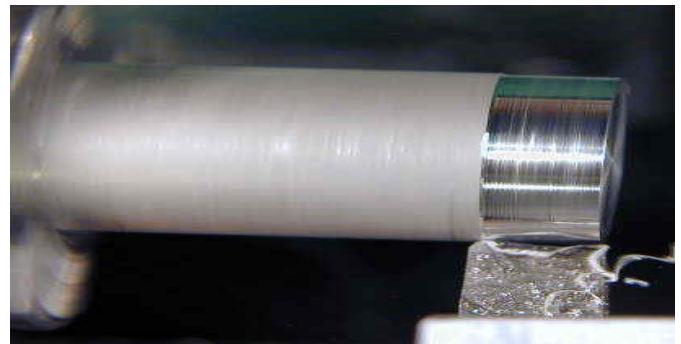

Fig -19: Turning Operation

Turning can be either on the outside of the cylinder or on the inside to produce tubular components to various geometries. The turning process is done on a lathe and are of four different types like straight turning, taper turning, profiling or external grooving. Different shapes like straight, conical, curved, or grooved work piece can be produced by these processes. In general, turning uses simple single-point cutting tools.

6.4 Drilling

Drilling is a process to cut a hole of circular cross-section in solid materials by using drill bits. The bit is a multipoint cutting tool of rotary type. The bit is pressed and rotated against the work piece at a rate from hundreds to thousands of revolutions per minute. This forces the cutting edge to cut off chips from the hole during drilling.



Fig -20: Drilling Operation

7. COST ESTIMATION

Table -1: Cost Estimation

| Sl no | Item | Material | Qty | Cost in Rs. |
|-------|-----------------------|------------------|-------|-------------|
| 1 | Wheel | Iron | 3 | 900 |
| 2 | Handle | Iron | 1 | 550 |
| 3 | Treadmill mat | PVC | 1 | 800 |
| 4 | Treadmill rollers | Galvanised steel | 10 | 6000 |
| 5 | Gears | Cast iron | 4 | 1500 |
| 6 | Sprocket | Cast iron | 2 | 900 |
| 7 | Chain | Alloy steel | 3 | 3000 |
| 8 | Stand | Steel | 1 | 1000 |
| 9 | DC Generator (12V,6W) | - | 1 | 2000 |
| 10 | Bearing | Steel | 8 | 800 |
| 11 | Frame | Aluminium | 20 kg | 600 |
| 12 | Storage battery | 12 V Li-ion | 1 | 1200 |
| 13 | Break system | Bourdon | 2 | 1200 |
| 14 | Cables | Copper | 2 | 1000 |
| | | Total | | 20450 |

8. ADVANTAGES AND DIS ADVANTAGES

| Advantages | Dis advantages |
|---------------------------|--|
| ✓ Noiseless operation | ✓ Speed of the vehicle is limited |
| ✓ Use of fuels is avoided | ✓ Load carrying capacity of the vehicle is limited |
| ✓ No pollution | ✓ Need plane smooth road |
| ✓ Low cost | ✓ Can't withstand heavy load |
| ✓ Workout easiness | ✓ Speed of the vehicle is limited |

| | |
|--|--|
| ✓ Can reach destination during workout | ✓ Load carrying capacity of the vehicle is limited |
| ✓ Time conservation | |

9. CONCLUSIONS

In this paper, a new way of travelling as well as exercise with the help of a new model of tricycle which is combination of treadmill and tricycle is discussed. It can be used in place of regular bike at cheaper cost and without use of fuel. The treadmill tricycle will prove to be a future vehicle as no fuel is used for travelling through this and it is pollution free. The treadmill which is used for walking helps to keep us fit as exercise is also one of the important task for a person to be fit and healthy for day to day life. Treadmill tricycle is cheaper than the normal bike which also makes it efficient and economic.

Exercise

Treadmill tricycle helps in maintaining proper physique. As physical fitness is important in day to day life. By using treadmill tricycle one can exercise outdoors in fresh air.

Fuel saving

People often use vehicle for travelling over short distance. This causes unnecessary wastage of fuel. Due to use of treadmill tricycle over short distance a large amount of fuel can be saved.

Travelling

Treadmill tricycle can be used for travelling over short distances. One can also exercise while travelling over short distance.

Eco- friendly

Treadmill tricycle does not require any fuel. Therefore, it does not emit any pollutants. So, it is an eco-friendly vehicle.

10. FUTURE SCOPE

In future, the tricycle can be run by the electrical energy stored previously in the battery. So, after travelling manually to destination, the return travel can be done by electrical power. It is the Effective way to convert human energy into electrical power while exercising. Combination of two or more process in a single system that makes time conservation in busy life.

REFERENCES

- [1] **Manish Debnath**, "Generation of electricity by running on a leg-powered treadmill" International Journal of Latest Research in Engineering and Technology (IJLRET) ISSN: 2454-5031(Online) www.ijlret.com|| Volume 1 Issue 7||December 2015 || PP 04-07

- [2] **Kirtish Bondre, Sanket Beradpatil, S. J. Thorat,** "Design and Fabrication of Treadmill bicycle" International Journal of Innovative Research in Science, Engineering and Technology (An ISO 3297: 2007 Certified Organization) Vol. 5, Issue 6, June 2016



I, Afsal Thajudeen
Final year B-Tech student,
Dept. of Mechanical Engineering
Sree Narayana Institute of
Technology, Adoor

- [3] **Adeel Ansari, Noman Raza, Farooqui Sameer, Zohaib Shaikh, Professor Arshad Rashid** "Treadmill Bike" International Journal of Modern Trends in Engineering and Research e-ISSN No.:2349-9745, Date: 28-30 April, 2016



I, Desareth S
Final year B-Tech student,
Dept. of Mechanical Engineering
Sree Narayana Institute of
Technology, Adoor

- [4] **Caspersen CJ, Powell KE, Christenson GM.** Physical activity, exercise, and physical fitness: definitions and distinctions for health-related research. Public Health Reports. 1985; 100(2):126-131.

- [5] **Wolthuis, R. A., Froelicher, V. F., Fischer, J., Noguera, I., Davis, G., Stewart, A. J., & Triebwasser, J. H.** (1977). New practical treadmill protocol for clinical use. The American journal of cardiology, 39(5), 697-700.



I, Jishnu V
Final year B-Tech student,
Dept. of Mechanical Engineering
Sree Narayana Institute of
Technology, Adoor

- [6] **Kooijman, J. D. G., and A. L. Schwab.** "Experimental validation of the lateral dynamics of a bicycle on a treadmill." ASME 2009 International Design Engineering Technical Conferences and Computers and Information in Engineering Conference. American Society of Mechanical Engineers, 2009.

- [7] **Kisan, Ravikiran, et al.** "Treadmill and bicycle ergometer exercise:

- [8] Design data book -P.S.G.Tech.

- [9] Machine tool design handbook -Central machine tool Institute, Bangalore.



I, Nithin Prasad,
Final year M-Tech student,
Dept. of Mechanical Engineering
(Specialized in Machine Design),
Sree Narayana Institute of
Technology, Adoor

BIOGRAPHIES



I, Abhiram R
Final year B-Tech student,
Dept. of Mechanical Engineering
Sree Narayana Institute of
Technology, Adoor



I, Anuraj A R,
Assistant Professor,
Dept. of Mechanical
Engineering,
Sree Narayana Institute of
Technology, Adoor