

“STRENGTHENING OF BEAM-COLUMN JOINTS IN RC FRAMES USING STEEL SECTIONS”

Ganesh B. Kawale¹, Dr. G.R. Selokar², Dr. Ashok L.Varne³, Prof. R. S. Narkhede⁴

¹ Research scholar, Department of Civil Engineering, SSSUTMS, Sehore, Bhopal, M.P., INDIA

² Dr. G.R. Selokar, Professor and Registrar, SSSUTMS

³ Prof. Ashok L. Varne: Associate Professor, Dept. of Civil Engineering, K. K. Wagh college of Engineering and Research centre, Nashik, M.H., India.

⁴ Research scholar, Department of Civil Engineering, SSSUTMS, Sehore, Bhopal, M.P., INDIA

Abstract - There are many details for reinforced concrete frame joints. Few of these details could satisfy the strength requirements, cracking and ductility. But the joint are still the weakest part in structural system. Observations made after earthquake, accidental loading shows that breakdown at the joint is the most frequent cause of failure of element connected. Distribution of stresses at an opening corner indicates that high tensile stresses exist at the inner corner normal to diagonal, coupled with tensile stresses along the diagonal. This paper explains the objectives to strengthen the joint to avoid the tensile stresses which causes the diagonal cracks at the joint. Five types test models are considered to analysis having different attachment to the corner for strengthening purpose. The models are subjected to heaviest load. Analyzed by using *Stad-pro*. The solid steel plates are found as an outstanding solution but attachment is very difficult. Chamfering is also helpful to this condition but cracks are developed in this case. The two angular plates are used to avoid diagonal cracks.

Key Words: : Beam column joint, Framed structure, Ductility, Joint strength, Steel sections, Chamfering, Angular Plates, Opening Moments.

1. INTRODUCTION

In the design of reinforced concrete structure, the greatest attention is paid to calculating strength of the basic structural element like beams, columns and slabs. But the joint are still the weakest part in structural system. Observations made after earthquake, accidental loading shows that breakdown at the joint is the most frequent cause of failure of element connected. Corner joint of single bay, single storey portal frame, water tanks, staircases, bridge abutment are the some example of reinforced concrete joint¹

In the analysis of reinforced concrete moment resisting frames the joints are assumed as rigid. There have been many catastrophic failures reported in the past earthquakes,

in particular with Turkey and Taiwan earthquakes occurred in 1999, which have been attributed to beam-column joints.⁷

Distribution of stresses at an opening corner indicates that high tensile stresses exist at the inner corner normal to diagonal, coupled with tensile stresses along the diagonal.¹

2. SCOPE AND OBJECTIVES

2.1 SCOPE

The beam column joint is the critical zone in a reinforced concrete moment resisting frame. It is subjected to huge forces during severe ground shaking and its behavior has a significant effect on the response of the structure. The assumption of joint being rigid fails to consider the effects of huge shear forces developed within the joint.

The principles of detailing and the structural behavior of simple structural members such as beams and columns are well developed in last decades. On the other hand, the detailing, strength and behavior of corner joints, especially those subject to huge opening moments as in the case of cantilever retaining walls, bridge abutments, channels, liquid retaining structures and portal frames, has not been conclusively determined. Reinforcement detailing at corners plays a basic role in influencing the structural behavior of the joint so in the case of opening joints or opening corners. The reinforcement details must be such that its layout and actual work at site are easy and the structural member should satisfy the basic requirements of strength expressed in terms of joint efficiency, controlled cracking, ductility and last but not the least, ease and simplicity of construction.

2.2 OBJECTIVE

The main objectives are that to strengthen the joint to avoid the tensile stresses which causes the diagonal cracks at the joint. The tensile stresses are developed due to the following points

- 1) Weak link theory
- 2) Deterioration mechanisms
- 3) Detailing

The point says that the link between the reinforcement at the joint is very weak; due to this the shear stresses developed are not properly resisted. And the diagonal cracks are developed. At the joint the detailing are not done properly. As per practical point view the design detailing is very congested and does not follow the design details. If done the concreting work is very critical.

In the existing framed structure the joints are the weakest part of the frame in case of earthquake forces the maximum framed structure are failed due to the weak joint. Therefore we have to strengthen the joints.

3. PREVIOUS STUDIES

Four different detailing systems had investigated by B Singh and Prof. S. K. Kaushik [6]. The parameters of investigation were: strength measured in terms of joint efficiency, ductility, crack control, and ease of reinforcement layout and fabrication facilitating effective placement of concrete in the member. It has been found that none of the detailing systems investigated satisfied all the four parameters. A substantial increase in post-cracking tensile strength, ductility and crack control can be achieved by adding steel fibers to the concrete. Therefore, the four detailing systems investigated previously were tested afresh with 50 mm long crimped-type flat steel fibers at a lower bound 0.75% volume fraction. The tests revealed at this volume fraction 15%-45% improvement in efficiency and a significant enhancement of ductility and toughness in almost all specimens.

The most critical type of joints is the joints subjected to opening moments, which produce tensile stresses in the inside surface of the corner. Four medium-scale reinforced concrete open moment joints were tested by Ashraf Biddah [4] under four points loading. One joint was used as control joints. One joint was designed according to current codes with adequate anchorage of the reinforcement at the joints. One joint with CFRP L shaped laminates were strengthened and tested. The test results indicate the feasibility of using CFRP L-shaped laminates to resist the slippage and provide adequate anchorage of the reinforcement into reinforced concrete frame joints.

G.M. Calvi et al [10] Experimental tests on six 2/3 scaled beam-column subassemblies, with structural deficiencies typical of Italian construction practice between the 50's and 70's, were performed under simulated seismic loads. Interior, exterior tee and knee joints, characterized by the use of smooth bars, inadequate detailing of the reinforcement deficiencies in the anchorage and the absence

of any capacity design principles, were subjected to quasistatic cyclic loading at increasing levels of inter storey drift. The experimental results underlined the significant vulnerability of the joint panel zone region and the critical role of the slippage phenomena due to the use of smooth bars and of inadequate anchorage

V.N. Dhar and Dr. P K Singh, [1] investigated the effect of chamfer as well as reinforcement detailing on strength and behavior of opening corners. A linear finite element analysis supported by experimental program has been for the investigated. A simple strut-and tie model (STM) for opening corner has been proposed to decide the area of reinforcement and its layout within the corner zone. Finally the amount of reinforcement and chamfer to be provided in opening corners, including the case of liquid retaining structures have been suggested

4. BEAM COLUMN JOINTS

4.1 TYPES OF JOINTS IN FRAMES

The joint is defined as the portion of the column within the depth of the deepest beam that frames into the column. In a moment resisting frame, three types of joints can be identified viz. interior joint, exterior joint and corner joint (Fig.1). The severity of forces and demands on the performance of these joints calls for greater understanding of their seismic behavior. These forces develop complex mechanisms involving bond and shear within the joint.⁹

4.2 FORCES ACTING ON A BEAM COLUMN JOINT

The pattern of forces acting on a joint depends upon the configuration of the joint and the type of loads acting on it. The effects of loads on the three types of joints are discussed with reference to stresses and the associated crack patterns developed in them. The forces on an interior joint subjected to gravity loading can be depicted as shown in Fig. 2(a). The tension and compression from the beam ends and axial loads from the columns can be transmitted directly through the joint. In the case of lateral loading, the equilibrating forces from beams and columns, as shown in Fig. 2(b) develop diagonal tensile and compressive stresses within the joint. Cracks develop perpendicular to the tension diagonal A-B in the joint and at the faces of the joint where the beams frame into the joint. The forces in a corner joint with a continuous column above the joint (Fig. 3) can be understood in the same way as that in an exterior joint with respect to the considered direction of loading. Wall type corners form another category of joints wherein the applied moments tend to either close or open the corners. Such joints may also be referred as knee joints or L-joints. The

stresses and cracks developed in such a joints are shown in Fig. 4. Opening corner joints tend to develop nascent cracks at the reentrant corner and failure is marked by the formation of a diagonal tensile crack. The forces developed in a closing joint are exactly opposite to those in an opening corner joint. These joints show better efficiency than the opening joints. During seismic actions, the reversal of forces is likely and hence the corner joints have to be conservatively designed as opening joints with appropriate detailing. Failure of opening corner or knee joint is primarily due to the formation of diagonal tension crack across the joint with the outer part of the corner concrete separating from the rest of the specimen. 9

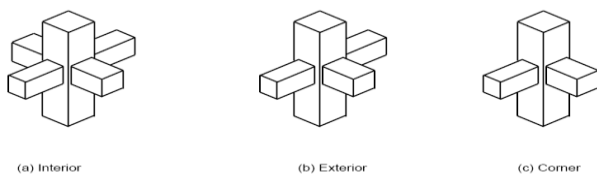

Fig. - 1: Types of Joints in a frame

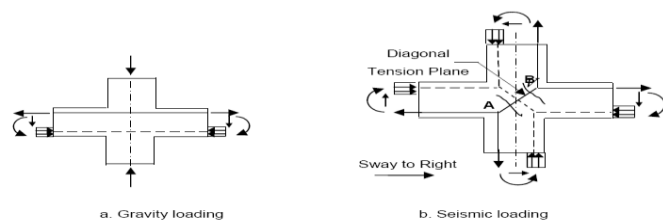

Fig. - 2: Interior joint

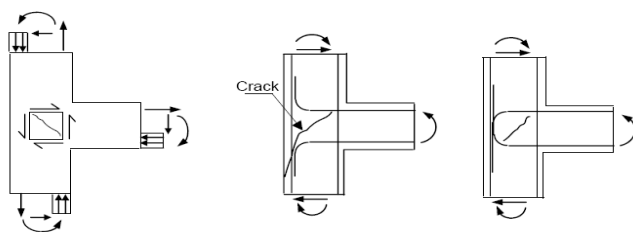

Fig. - 3: Exterior Joint

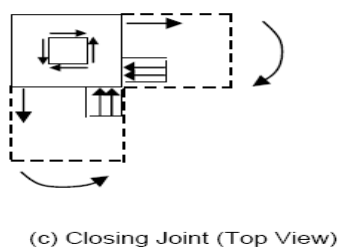
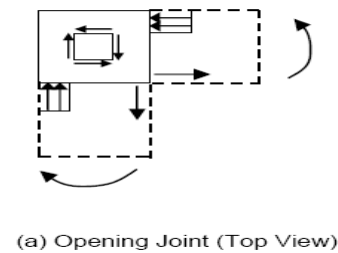

Fig. - 4: Corner joints

4.3 DESIGN OF JOINTS

- **Type I – Static loading**
 - strength important
 - ductility secondary
- **Type II – Earthquake and blast loading**
 - ductility + strength
 - inelastic range of deformation
 - stress reversal
 - Joints should exhibit a service load performance equal to that of the members it joins.
 - Joints should possess strength at least equal to That of the members it joins (sometimes several times more).
 - Philosophy: Members fail first, then joints.
 - The joint strength and behavior should not Govern the strength of the structure.
 - Detailing and constructability.

4.4 BEHAVIOR OF JOINTS

4.4.1 KNEE JOINT

Typical example of a portal frame. The internal forces generated at such a knee joint may cause failure with the joint before the strength of the beam or column. Even if the members meet at an angle, continuity in behavior is necessary.

4.4.2 CORNER JOINTS UNDER CLOSING LOADS

☑ Biaxial compression $\epsilon > 0.003$

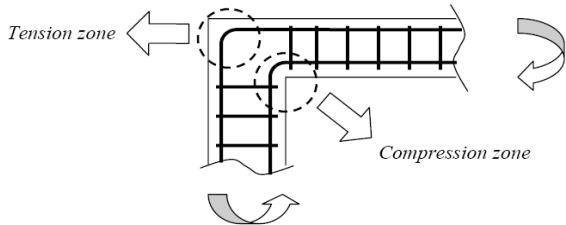

Fig. - 5: Tension zone compression zone of joint of applied inward forces

4.5 FACTORS INFLUENCING JOINT STRENGTH

1. Tension steel is continuous around the corner (i.e., not lapped within the joint).
2. The tension bars are bent to a sufficient radius to prevent bearing or splitting failure under the bars.
3. The amount of reinforcement is limited to

$$\rho \leq \frac{6\sqrt{f_c}}{f_y}$$

4. Relative size will affect strength and detailing for practical reasons. The joint strength:

$$f_t' = \frac{T}{bd} = \frac{A_s f_y}{bd} = \rho f_y \cong 6\sqrt{f_c}$$

$$f_t' > \rho f_y \rightarrow \rho \leq \frac{f_t'}{f_y} \cong \frac{6\sqrt{f_c}}{f_y}$$

• Joint core

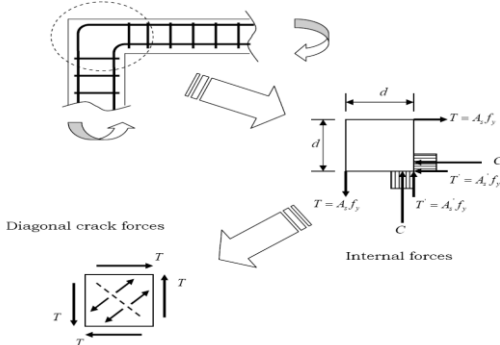

Fig. - 6: crack forces and internal forces

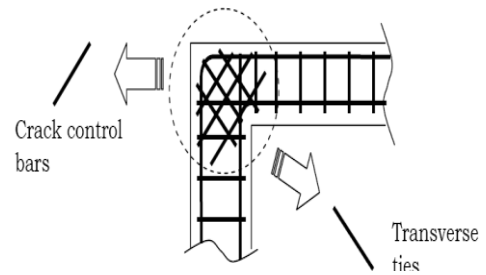

Fig. - 7: cracking control bars

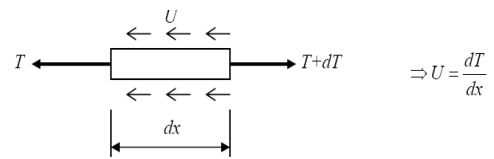

Fig. - 8: Bend force

4.6. BEHAVIOR UNDER SEISMIC LOADING

- Concrete with joint cracks due to cycling.
- Degradation of bond strength.
- Flexural bars should be anchored carefully.
- No benefit should be expected from axial loads.
- Rely on ties within the joint.
- Effects from both opening and closing should be considered.
- An orthogonal mesh of reinforcing bars would be efficient.

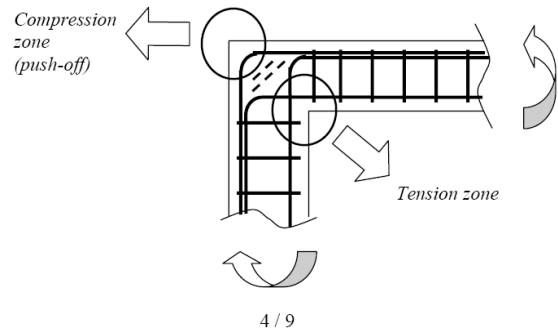

Fig. - 9: tension and compression zone of applied outward forces.

5. ANALYSIS

- Five types test models are considered to analysis having different attachment to the corner for strengthening purpose.
1. A first model is considered with no attachment at the inner joint with concrete material as shown in fig.10

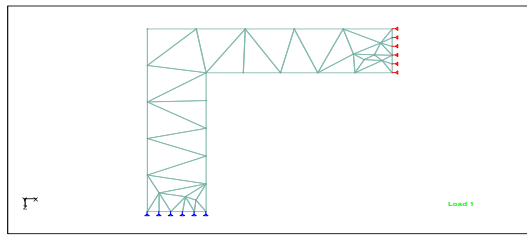

Fig. - 10: Frame showing column joint only

2. Second model is considered with giving chamfer at the inner joint of beam column joint as shown in fig.11

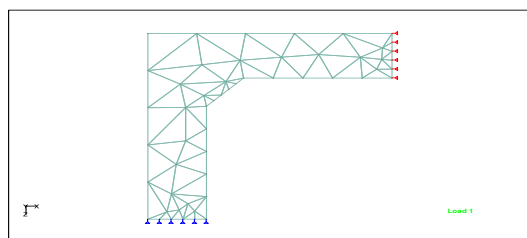

Fig. - 11: Frame showing column joint Concrete Chamfer

3. Third model considered with triangular Solid steel plate at the inner joint of beam column joint as shown in fig. 12

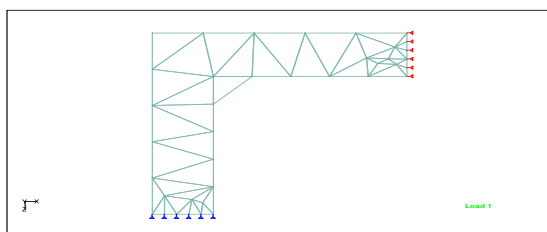

Fig. - 12: Frame showing column joint Triangular steel plate

4. Forth model considered with two steel plate at the inner joint of beam column joint as shown in fig. 13

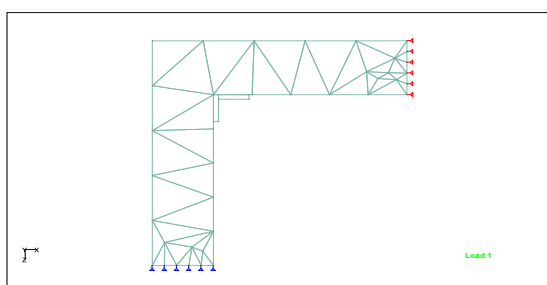

Fig. - 13: Frame showing column joint with two steel plate

5. Fifth model considered with Hollow triangular steel plate at the inner joint of beam column joint as shown in fig. 14

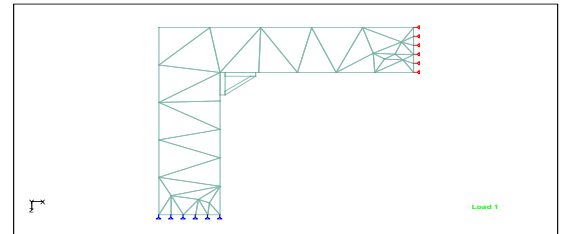

Fig. - 14: Frame showing column joint hollow triangular plates

Length of member are considered to 3.0 and considered 120 mm thick plate. Framing member are considering all the requirement of limit state method of reinforced concrete design. Loading are applied as live load dead load and lateral forces as per Indian Standard code of IS1893-2, 2002

5.1 MATERIAL

In all models the framing materials are of concrete confirming all the requirement of IS 456-200012 and steel plate as IS 80013. The models are subjected to heaviest load. Analyzed by using Staad-pro 2006 software. In this software the Geometry are created with varies shapes at the inner joint of the beam then applying varies loads such as the Dead load, live load, Combination of these two loads.

6. RESULT AND DISCUSSION

In the present investigation, analysis is supported by stress analysis of stad-pro-2006 software has been carried out to study the effect of chamfers with concrete material as well as steel plate at the inner joint stad analysis result for all models subjected to same loading cases are presented in following fig.

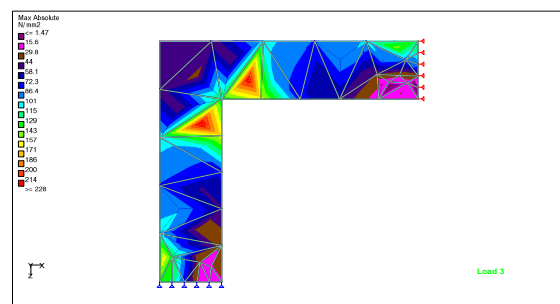

Fig.No.15 Stresses of frame showing column joint only.

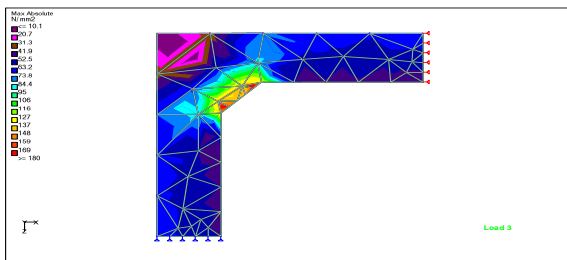

Fig.No.16 Stresses of frame showing column joint Concrete Chamfer

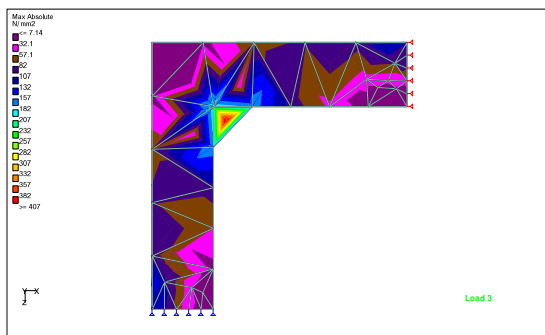

Fig.No.17 Stresses of Frame showing column joint Triangular steel plate

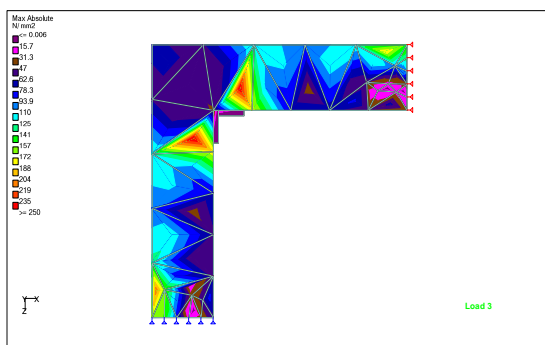

Fig.No.18 Stresses of Frame showing column joint with two steel plate

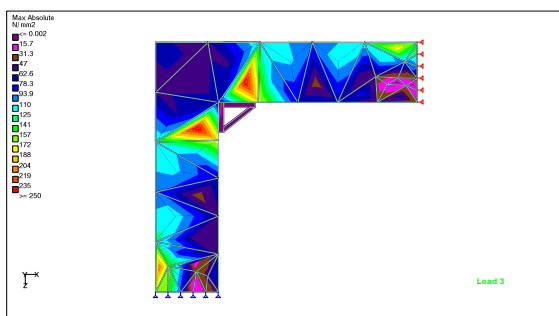

Fig.No.19 Stresses of Frame showing column joint hollow triangular plates

From above figures i.e. fig.no.15 to 19, it shows the variation of stresses at the overall frame shown. If we observe the fig.no.15 it shows the stresses are maximum at the inner joint of frame which causes cracks at the inner joint of frame. Such types of stresses are very harmful to the structures. To avoid these stresses detailing is required, but detailing are reduce these stresses limited. As stresses are remains at the joint to avoid these stresses various alternatives are studied in the analysis. These are shows the following results

In the first model giving the concrete chamfer to the inner joint, it absorbs whole these stresses but at the junction of chamfer and beam there is maximum stresses which are developed. So to reduce these details we have to design the stirrups or links by considering stresses. As shown in fig. no.16

In the second model giving the Steel chamfer to the inner joint, it absorbs whole these stresses as shown in fig.no.17

In the Third model giving the two plates of steel forming angle section at the inner joint, it absorbs some of these stresses but some part of stresses are remains at some distance from diagonal axis of the corner. So for these remaining stresses we have design separately as per is 13920 code for detailing. As shown in fig.18

In the fourth model giving the three plates of steel forming triangular section at the inner joint, it shows the result as mentioned third model. As shown in fig.19

Out these four models the second model is very much useful for that purpose.

7. CONCLUSION

In Indian design practice, beam column joint has been given less attention than it actually deserves. In this study, the common types of joints in reinforced moment resisting frames have been discussed. The mechanics and design of beam column joint are studied. Also in this study the behavior of beam column joint under seismic actions are studied.

In this study, the solid steel plates are considered as an outstanding solution but attachment is very difficult. The cost of steel is very costly. Chamfering is also helpful to this condition but cracks are developed in this case. The two angular plates are used to avoid diagonal cracks. The remaining stresses will be designed for the shear as Indian standard code.

8. REFERENCES

1. Dhar V.N. , Dr.Singh P.K. " Chamfering and reinforcement detailing in reinforced concrete corner subjected to opening moment" IE(I) Journal Feb-2004, 244-251.
2. Johansson M., "Reinforcement Detailing In Concrete Frame Corners". ACI Structural Journal, January-February, 2001, pp 105-114.
3. Buyulozturk O. "Mechanics and Design of Concrete Structures (3-0-9)". Spring 2004.
4. Biddah A." Strengthening of Opening Joints in Reinforced Concrete Frames Using Cfrp" The Seventh Annual U.A.E.University Research Conference,pp170-175.
5. Biddah A. "Seismic Behavior of existing and rehabilitated reinforced concrete frame connections".
6. Singh B., Prof. Kaushik S.K. " Investigation on fiber Reinforced Concrete Opening Corners" IE(I) Journal November 2003,pp 201-209 .
7. Dr. Uma S.R., Prof. Meher Prasad A." Seismic Behavior of Beam Column Joint in Reinforced Concrete Moment Resisting Frames" IITK-GSDMA-EQ31-V1.0
8. Sukrawa M., Pringgana G., Sudarsana I K. " Behavior of RC T-Beams Strengthened with steel plate" 2nd Asian Concrete Federation Conference-Bali, Indonesia, November 20-21,2006.
9. Dr. Uma S.R., Dr. Jain S.K." Seismic Behavior of Beam Column Joint in reinforced Concrete moment Resisting Frames" IITK-GSDMA-EQ31-V1.0
10. Pampanin S., Cali G.M., Moratti M.," Seismic behavior of R.C. Beam-Column Joints Designed for Gravity Loads" 12th European Conference on earthquake Engineering Paper Reference 276.
11. Duggal S.K.," Earthquake Resistant Design Of Structure", pp 270-296
12. IS: 456-2000." Codes of practice for plain and Reinforced Concrete "Bureau Indian Standard, New Delhi.
13. IS: 800-1984." Codes of practice for plain General Construction in Steel "Bureau Indian Standard, New Delhi.

BIOGRAPHIES



Ganesh B. Kawale, Research scholar, SSSUTMS, Sehore, Bhopal, M.P., Sr. Lecturer, [B.E. Civil, M.E. Structure,] in Department of Civil Engineering, MET Institute of Technology (P). He has done various MSBTE Activities. He has 12 Years in Teaching and 3 years Industrial Experience.



Dr. G.R. Selokar, Professor and Registrar, SSSUTMS



Prof. Dr. Ashok L Varne, Associate Professor, Dept. of Civil Engineering, K. K. Wagh college of Engineering and Research center, Nashik, M.H., India.



Research scholar, Department of Civil Engineering, SSSUTMS, Sehore, Bhopal, M.P., INDIA