

Compensation of Balanced and Unbalanced voltage disturbance using SRF controlled DVR

Ms Priyanka N. Nimje¹, Ms Bushra Khan²

¹PG Student, Department of Electrical Engineering (IPS), Abha Gaikwad Patil College of Engineering
Mohgaon, Nagpur-09, India

²professor Department of Electrical Engineering (IPS), Abha Gaikwad Patil College of Engineering
Mohgaon, Nagpur-09, India

Abstract - The growth of power electronic technology in the field of electric power sector has caused a greater awareness on the power quality of distribution systems. With the re-structuring of power systems and with shifting trend towards distributed and dispersed generation, the issue of power quality is going to take newer dimensions. The present research is to identify the prominent concerns in this area and hence the measures that can enhance the quality of power. The research work is going to be investigates the problems of voltage sag, swell and its severe impact on nonlinear loads, sensitive loads. Protection of the sensitive unbalanced nonlinear loads from sag/swell, distortion, and unbalance in supply voltage is achieved economically using the dynamic voltage restorer (DVR). DVR is installed between supply and load which will inject voltage and active power to the distribution system during balanced/unbalanced voltage sag and swell disturbances. The control technique used to operate the DVR is SRF Theory with Proportional Integral (PI) controller. The performance of DVR based Synchronous reference frame theory (SRF) for the mitigation of voltage sag, swell for balanced and unbalanced voltages is going to be tested and Simulation results are going to be carried out by PROTEUS with its Simu-link to analyze the proposed method.

Key Words: SRF (synchronous reference frame theory), DVR (dynamic voltage restorer), balanced and unbalanced voltage.

1. INTRODUCTION

In power distribution systems the advent of a large numbers of sophisticated electrical and electronic equipment such as computers, programmable logic Controllers and variable speed drives causes various power quality problems like voltage sag, voltage swell and harmonics. These are the major concern of the industrial and commercial electrical consumers due to enormous loss in terms of time and money, in which voltage sag and swell are major power quality problems.

Voltage sags and swells are the most common power quality problems in electrical distribution systems. Voltage sag is defined as decrease in the rms value of voltage magnitude. Voltage swell is defined as increment in the rms value of voltage magnitude. There are two types of voltage sag and swell which can occur on any transmission lines; balanced and unbalanced voltage sag and swell which are also known as symmetrical and asymmetrical voltage sag and swell respectively. Most of these faults that occur on power systems are not the balanced three-phase faults, but the unbalanced faults. In the analysis of power system under fault conditions, it is necessary to make a distinction between the types of fault to ensure the best results possible in the analysis. In balanced voltage sag & swell, voltage decreases and increase in all three phases simultaneously. In unbalanced voltage sag & swell voltage decrease and increases in only one phase or two phases at a time.

1.1 Overview

Custom power devices are used to compensate these power quality problems in the systems. There are different types of Custom power devices used in electrical network to improve power quality problems. Each of the devices has its own benefits and limitations. A few of these reasons are as follows. The SVC (Static Var Compensator) pre-dates the DVR, but the DVR is still preferred because the SVC has no ability to control active power flow. Another reason include that the DVR has a higher energy capacity compared to the SMES (Super Conducting Magnetic Energy Storage) and UPS devices. Furthermore, the DVR is smaller in size and cost is less compared to the DSTATCOM (Distributed Static Compensator) and other custom power devices. Based on these reasons, it is no surprise that the DVR is widely considered as an effective custom power device in mitigating voltage sags. In addition to voltage sags and swells compensation, DVR can also add other features such as harmonics and power factor correction. Compared to the other devices, the DVR is clearly considered to be one of the best economic solutions for its size and capabilities. Dynamic Voltage Restorer is located between grid and sensitive load. It injects controlled voltage to keep dc link voltage constant at load-side.

The proposed DVR is connected to the system through the three single phase injection transformers. DVR is designed according to the voltage needed in the secondary side of transformer. The DVR consists of three single phase VSI units. Each unit is connected to system through the injection transformer. It provides the isolation to the converter. The performance of DVR depends up on control strategy used. In this paper SRF Theory with Proportional Integral (PI) controller technique is used for compensation of balanced/unbalanced voltage sag and swell.

The generation of V_d , V_q and V_o SRF Controlled DVR For Compensation of Balanced and Unbalanced Voltage Disturbances reference signal involves the conversion from three-phase to two-phase and vice versa. Moreover low pass filters are essential part of this algorithm which has slow dynamic response of the compensator. The paper is organized as follows. In section 2, the configuration part of the DVR is described, the Control technique and the voltage injection capabilities of the DVR is discussed in section 3, and the detailed description of PROTUES Simulation model along with its performance in electrical network is discussed in section 4.

2. PROBLEM DEFINATION AND OBJECTIVES

Power quality is very important issue recently due to the impact on electricity suppliers, equipment manufacture and customers. Power quality is described as the variation of voltage, current and frequency in a power system. It refers to a wide variety of electromagnetic phenomena that characterize the voltage and current at a given time and at a given location in the power system. Nowadays, there are so many industries using high technology for manufacturing and process unit. This technology requires high quality and high reliability of power supply. The industries like semiconductor, computer, and the equipments of manufacturing unit are very sensitive to the changes of quality in power supply. Power Quality problems encompass a wide range of disturbances such as voltage sags/swells, flicker, harmonics distortion, impulse transient, and interruptions. Voltage sags/swells can occurs more frequently than other Power quality phenomenon. These sags/swells are the most important power quality problems in the power distribution system.

One of the best solutions to improve power quality is the dynamic voltage restorer (DVR). DVR is a kind of custom power devices that can inject active/reactive power to the power grids. This can protect loads from disturbances such as sag and swell. Usually DVR installed between sensitive loads feeder and source in distribution system. Its features include lower cost, smaller size, and its fast dynamic response to the disturbance. In this project SRF technique is used for conversion of voltage from rotating vectors to the stationary frame. SRF technique is also referred as park's

transformation. In this the reference load voltage is estimated using the unit vectors.

3. HARDWARE IMPLEMENTATION

In the above block the main aim is to control and keep balance the voltage across load. Initially controller checks the incoming voltage coming from line with the help of ADC (analog to digital converter) present inside the Microcontroller. Our aim is to control a +ve as well as -ve half cycle of incoming AC for that a Firing angle control method is used. For controlling a firing angle of any AC voltage it is necessary to monitor every +ve/-ve half cycles, hence a Sine Wave Cycle Monitor(Zero Crossing Detector) block is used in our project, which informs a controller about start point of every cycle. Once controller knows the voltage across the load and signals from sine wave cycle monitor, controller calculate the firing angle and gives firing pulse to the AC to AC converter in which a static switch formed by a SCR/TRIAC is used. Static switch can operated on high voltage and high frequency as compare to the mechanical switches like relay.

The output of AC to AC converter is further give to Reactor which is nothing but a type of single core step-up transformer.(220v to 300v transformer is used in our project), which gives a 220v output at 140vAC input. The output of 220v is further used by a various load. The voltage across load is measured by the controller with the help of Potential Transformer (PT). Potential transformer is used to step down the voltage across the load to be measure and rectified to DC, because microcontroller can read a voltage upto 5vdc only. In our project we are using a Relay for tripping the input voltage in case of very high voltage and low voltage which is beyond control-able limits. The relay used in our project is of 12 volts and controller can give maximum of 5v, hence it is necessary to amplify the 5v to 12v for which a Driver circuit is used. Microcontroller requires a 5vDC to work, and same will be generated with the help of Power Supply which comprises of a Step down transformer, rectifier, filter and regulator. Transformer step down the 220vAC to 12vAC, rectifier and filter converts this 12vAC to 12vDC, and regulator converts a 12vDC to a constant of 5vDC.Capacitor bank is a optional block which can be used in case of beyond limit regulation requires. As shown in Fig 3.1.

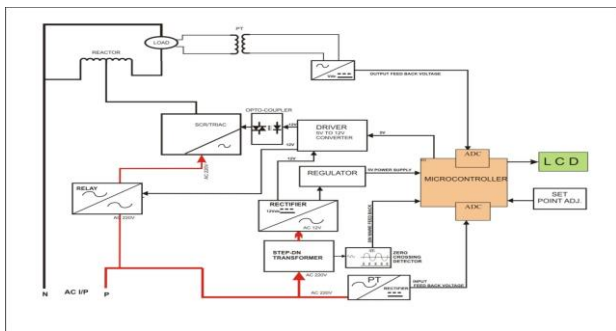

Fig 3.1 Block diagram of hardware implementation.

The following figure shows the Control Block Diagram of the DVR. In this control, Source Voltage is sensed and is given as an input to the abc/dq transformation block. The same source voltage is given as an input to the PLL block, this PLL block gives the information of sin, cos. This is given as an input to the abc/dq block, with these two inputs this transformation block gives V_d , V_q , and V_o information.

This information is compared with V_{dact} , V_{qact} and V_{oact} which are the actual parameters. The quadrature and V_o axis is compared with 0 p.u. The error generated is given as an input to the pi controller, the pi controller output is again given as an input to dq/abc block, and PLL information is also given as an input to dq/abc block. This block gives us the pulse information which is given as an input to pwm generator and from that gate pulses are generated, those gate pulses are for inverter. As shown in fig 3.2. But in this project we used Dimmerstate to create voltage disturbance. The role of voltage disturbance is played by Synchronous Reference Frame i.e instead of SRF we used Dimmerstate.

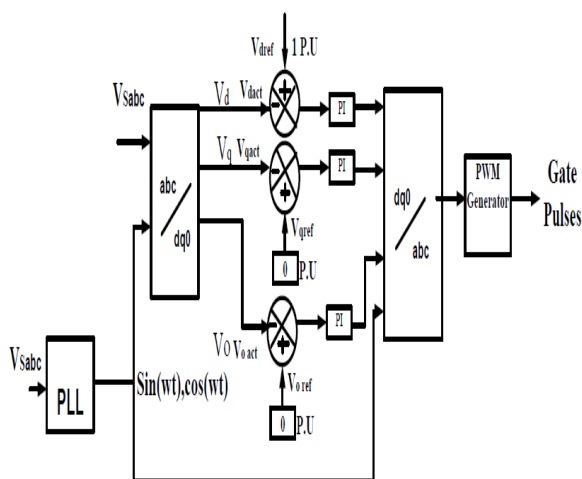

Fig 3.2 Block diagram of DVR controlled Synchronous reference frame.

4. SIMULATION RESULT

After getting a power supply on a 220v AC is first converted into a 12vAC with the help of center tap step-down transformer, as most of the control and monitoring circuit requires a various DC Sources, hence the 12vAC initially converted into 12vDC with the help of Rectifier and Filter made by using Diode D1,D2 and C1 of 1000uF. Microcontroller PIC is used in this circuit which requires a constant 5vDC. To convert a 12vDC to 5vDC, a Regulator IC 7805 is used, which keeps a 5vDC constant irrespective of any fluctuations between 6v to 28v.

Initially PIC checks the Input voltage & Output voltage. As the input and output voltage is very large and beyond the measuring limit of PIC, i.e. > 5vDC, hence a PT (potential transformer) of 220v/6v is used. The requirement of PIC for measurement is 0-5vdc, hence the output of PT also converted in a DC with the help of another rectifier and filter.

The main aim of circuit is to detect a Sag and Swell in input voltage and further it is corrected and make constant in output with some tolerance of (+/- 5%).

As we can Boost the voltage by some percent with the help of capacitor in case of Sag in Input voltage, but the boosted voltage cannot be controlled, Hence an active reactor is used, which can increase as well as decreases the voltage by controlling a Input voltage giving to it. In this circuit an active reactor can boost a voltage to 220v by giving a minimum voltage of 140v, and can boost a voltage upto 280v by giving a minimum voltage of 220v.

The value for output voltage is set between 200-215v. Whenever a controller detects an output voltage less than 200v, it decreases a firing angle used to trigger a Static Switch, which result to increase a output voltage after detecting a pulse from zero-crossing detector, until the output voltage come between tolerance, if controller detects an output voltage greater than 215v, it increases a firing, which result to decreases an output voltage after detecting a pulse from zero-crossing detector, until the output voltage is between the tolerance of 200-215, at that time it keeps the firing angle constant.

Zero crossing detector is used to detect every positive as well as negative half cycle. The zero crossing detector circuit is made with the help of diode D3,D4,D5, Resistances R1, R2, R3, R4 and Transistor T1,T2.

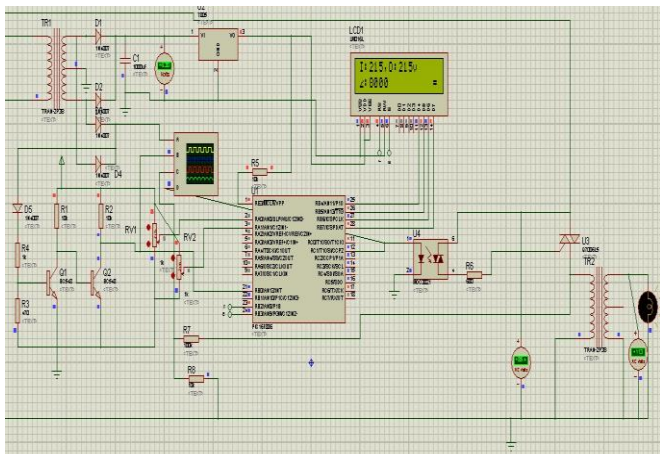
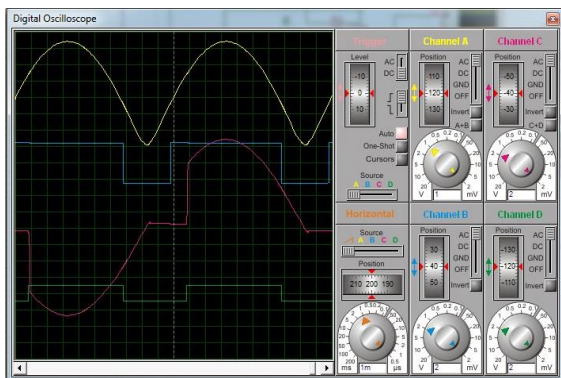

Fig 4 Simulation circuit diagram

Following are the result of simulations

	Result shows input voltage
	Result shows zero crossing output
	Result shows controlled output voltage
	Result shows triggering voltage i.e firing angle

- 1) When Output is equal to Input: In this the output voltage is equal, when the appropriate load is connected.



- 2) When Output is Greater than Input: In this the output voltage is greater than Input, which is due to open circuit of connected load. The output voltage is lower down by increasing the firing angle.

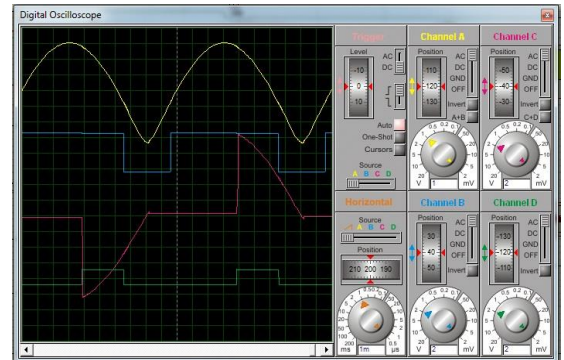

- 3) When Output is Less than Input: In this the output voltage is less than Input, which is due to heavy or over connected load. The output voltage is lower down by decreasing the firing angle.

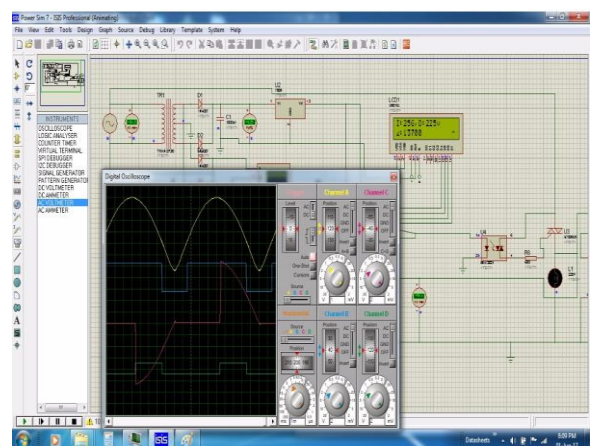
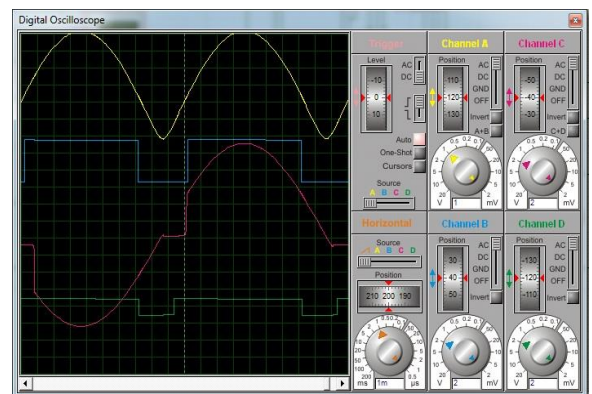

5. CONCLUSIONS

DVR is capable of compensating the various voltage disturbances like single phase and two phase sag and swell in unbalanced condition as well as sag and swell in unbalanced condition in three phases. Various conditions are tested for the performance capability of DVR through extensive simulation and results are verified. DVR is tested for balanced sag, swell, multiple sag and multiple swell and sag and swell cases, and in unbalanced condition sag and swell in single and two phases as well as unbalanced three phase condition.

In this research work we are going to improve the compensation of device by implementing the hardware model using facts device and PROTEUS -Simulation result using DVR based SRF controlled. The DVR is the best solution for mitigating the various voltage disturbances in a distribution system.

REFERENCES

- [1] Bollen MHJ. Understanding power quality problems. Piscataway, NJ: IEEE Press; 2006.
- [2] Lim PK, Dor DS. Understanding and resolving voltage Sag related problems for sensitive industrial customers. IEEE Power Eng Soc Winter Meet 2000; 4:2886–90.
- [3] S.LEELA, S.DASH “Control of three level inverter based DVR”
- [4] Rating and Design Issues of DVR Injection Transformer
- [5] Performance of DVR under different voltage sag and swell conditions by T. Devaraju, V. C. Reddy and M. Vijaya Kumar
- [6] Voltage Quality Improvement Using DVR by Chellali BENACHAIBA, Brahim FERDI Syed Suraya and Dr. K.S.R.Anjaneyulu
<http://www.iaeme.com/IJEET/index.asp> 92
editor@iaeme.com
- [7] Chellali BENACHAIBA, Bra-him FERDI, Voltage Quality Improvement Using DVR.
- [8] A. Ziane-Khodja, M. Adli, S. Bacha, Y. Zebboudj & A. Khireddine, Control of Voltage Sensitive Load Using A Dynamic Voltage Restorer Commanded In Current. *International Journal of Electrical Engineering & Technology*, 3(1), 2012, pp. 167–179.

[9] Saurabh Sahu and Neelesh Kumar, Mitigation of Power Quality Problems Using Dynamic Voltage Restorer (DVR). *International Journal of Electrical Engineering & Technology*, 6(8), 2015, pp. 86–98.

[10] B.Karthick, S.Kalaivanan and N.Amarabalan, Mitigation of Power Quality Problems In Three Phase Three Wire Distribution Systems Using Dynamic Voltage Restorer (DVR). *International Journal of Electrical Engineering & Technology*, 4(5), 2013, pp. 184–195.