

USAGE OF N₂ METHOD FOR THE PERFORMANCE EVALUATION OF PLAN ASYMMETRIC STRUCTURES

Swathi B S¹, Manjula K²,

¹P.G Student, Department of Civil Engineering BGSIT, BG Nagar, Mandya, Karnataka, INDIA

²Asst. Professor, Department of Civil Engineering BGSIT, BG Nagar, Mandya, Karnataka, INDIA

Abstract - In the present situation the most difficult task to earthquake engineer is to construct seismic resistant structures and design of structures against the seismic forces is necessary. Generally multistory building grasps irregularities both in plan and elevation. These irregularities attract large seismic forces during earthquake and leads to structural failure. The various aspects of pushover analysis and accuracy of pushover analysis in assessing seismic demands were investigated by several researchers. In the present work N₂ method is used to evaluate the performance of plan asymmetric buildings like one regular and four irregular models situated in zone III is considered. N₂ method is a simplified non linear static analysis also called pushover analysis is used. In this method elastic demand curve taken from IS 1893-2002 is converted into inelastic spectra in A-D format. Capacity curve of MDOF system of all the five models obtained from pushover analysis using ETABS 20015 is converted into SDOF system of spectral acceleration vs. spectral displacement using transformation factor. The intersection point of these two curves gives the performance point of structure which indicates the seismic demand of the structure. The effects of plan irregularity on the building is assessed in terms of dynamic parameters like capacity curves, performance point, storey drift, storey displacement and nonlinear hinge bar chart are evaluated by performing equivalent static analysis using IS 1893-2002 and pushover analysis and results are obtained in terms of SDOF system.

Key Words: N₂ Method, Pushover Analysis, Plan Irregularity, Performance Point.

1. INTRODUCTION

Earthquake defined as the vibration of the ground produced by seismic forces. These seismic forces cause inelastic behavior of the structure and leads to failure of the buildings. The various factors affecting to the structural damage during the earthquakes are vertical and plan irregularity in structures.

The structure having discontinuity in force path, mass, stiffness and geometry are called as irregular structures. Irregularities in structures cause more damage during earthquake because of more attraction of seismic forces. In construction of building irregularities are probably not avoided. However, the behavior of these irregular structures during seismic is need to be understand. More precautions should be needed. A detailed study of structural

behavior of building of building with irregularities is necessary for design and behavior in earthquake.

Peter Fajfar, M. EERI (2000) [1] In this paper they introduced new simplified methodology for seismic analysis of the structure called N₂ method. This method combines the pushover analysis of MDOF model with the response spectrum analysis of an SDOF system. S.C. Pendnekar, H. S. Chore, S. B. Patil(2015)[2] From this analysis result are with increase in number of stories indicates decreases in spectral acceleration and base shear and also with increase in number of spectral displacement, displacement and time period by performing nonlinear static pushover analysis. Dini Devassy Menachery, Manjula N. K (2014)[3] In this paper they used extended N₂ method procedure for performance evaluation of asymmetric setbacks and the results in terms of displacement and storey drifts obtained are compared with time history analysis.

1.1 N₂ Method

N₂ method is a simple nonlinear method for the seismic analysis of structures. It combines the pushover analysis of a multi-degree-freedom (MDOF) with the response spectrum analysis of equivalent single-degree-of-freedom (SDOF) system. The N₂ method, in its new format, is in fact a variant of the spectrum method based on inelastic spectra. Inelastic demand spectra are determined from a typical smooth elastic design spectrum. The reduction factors, which relate inelastic spectra to the basic elastic spectrum, are consistent with the elastic spectrum. The lateral load pattern in pushover analysis related to the assumed displacement shape. This feature leads to a transparent transformation from a MDOF system to an equivalent SDOF system and response of the structure is evaluated in terms of performance point.

Nonlinear Static Analysis

Non linear static procedure or pushover analysis is explained as the reaction of the structure to quake loadings. This procedure directly explains the redeployment of forces and deformations that occur in a structure as it go through inelastic reaction. As a result they are usually competent of providing more correct approximation of the demand needed in the structure than either of nonlinear procedures. From this analysis we can get result in the form of base shear verses roof displacement plot. The plot is converted into

capacity into demand plot with the intersection of capacity with demand being known as performance point

Pushover Curve

Pushover curve is base shear versus roof displacement curve inform about the shear force developed at the base of the structure at any level of pushing. The highest value of this curve characterize the maximum base shear, which indicates the highest load carrying capacity of the structure, the maximum roof displacement of the structure considered as the deflection beyond this limit leads to structural collapse.

Demand Curve

For a given ground motion and structure, the displacement demand is an estimate of the maximum expected response of the building during the ground motion. It is given by spectral acceleration (S_a) versus time period (T). In the present work the seismic demand is taken from IS: 456-2002 code for medium soil as shown in fig below.

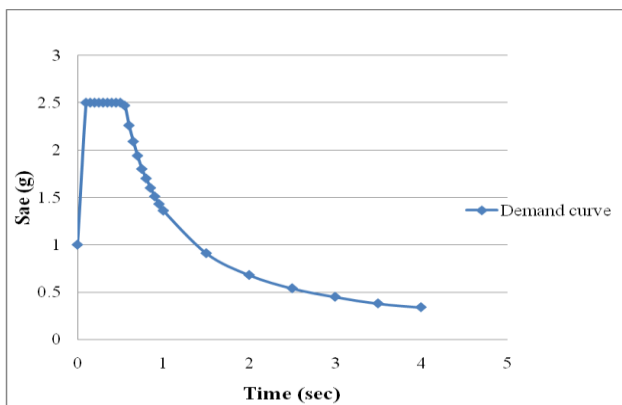

Fig 1 Response spectra for medium soil type for 5% damping in traditional format

Performance Point

The building performance under seismic loading can be estimated in expressions of capacity curve, performance point, ductility, displacements and creation of plastic hinge etc. From pushover analysis, base shear versus top displacement curve is achieved, from which maximum capacity of structure in terms of base shear can be achieved. This capacity curve is converted into capacity spectra by using any simplified methods like N2 method and response spectrum is taken from any of the standard code depending on type of soil. The intersection of capacity and demand spectra predict the performance point of the structure analyzed.

3. ANALYTICAL MODEL

3.1 Introduction

In these present study four stories of plan area 22.5mx22.5m structure is selected for analysis and the structure is located on a medium soil type in seismic zone III. Using ETABS-2015, three dimensional mathematical models of one regular and four irregular of same area are generated.

Beam size= 250x400 mm

Column size= 450x450 mm

Slab thickness= 150 mm

Wall thickness= 120 mm

Live load= 3KN/m²

Structure type= OMRF building

3.2 Application of N₂ method for regular model

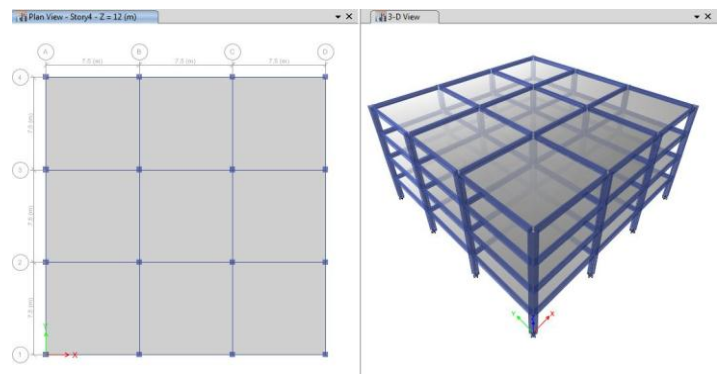

Fig 2 plan and 3-d view of regular model

Storey masses = [381.21, 432.31, 432.31, 432.31] tone

Displacement shape $\phi = [1, 0.77, 0.47, 0.16]$

The MDOF system is converted to an equivalent SDOF system using following equations.

$$\text{Equivalent mass of SDOF } m^* = \sum m_i \phi_i^2$$

$$m^* = 986.44 \text{ tone}$$

$$\text{Transformation factor } \Gamma = \frac{m^*}{\sum m_i \phi_i^2}$$

$$\Gamma = 1.3257$$

$$D^* = \frac{D_t}{\Gamma} = 2.48 \text{ cm} \quad F^* = \frac{V}{\Gamma} = 1060.32 \text{ kN}$$

Where D_t and V are top displacement and base shear obtained from pushover analysis of MDOF system

Bilinear idealization of pushover curve is done to obtain yield strength F_y and yield displacement D_y .

$$\text{The elastic time period is } T^* = 2\pi \sqrt{\frac{m^* D_y^*}{F_y^*}} = 0.95 \text{ sec}$$

From the response spectrum $S_a/g = 2.5$ and

Time period $T_c = 0.5$

$$S_a = \frac{F^*}{m^*}$$

The Period of the system T^* is larger than T_c , thus the equivalent rule applies. i.e., $\mu=R_{\mu}$, $S_d=S_{de}=23.63\text{cm}$.

Where S_a and S_d is the performance point of the structure. Same calculation is carried out for all the remaining models to get seismic demand of the structure in terms of SDOF system.

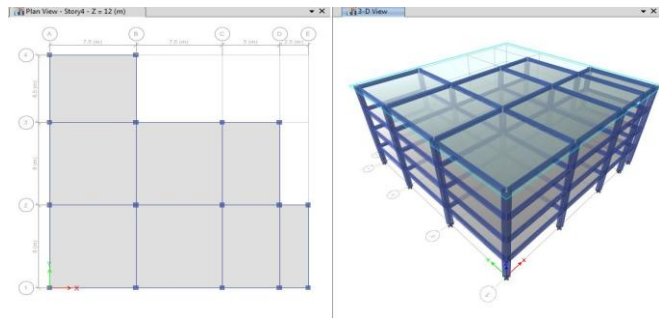

Fig 3 plan and 3-d view of irregular model 1

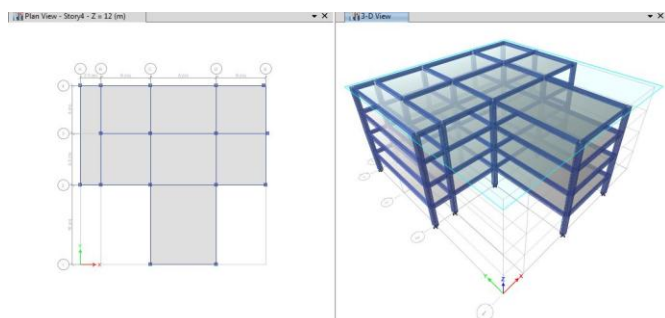

Fig 4 plan and 3-d view of irregular model 2

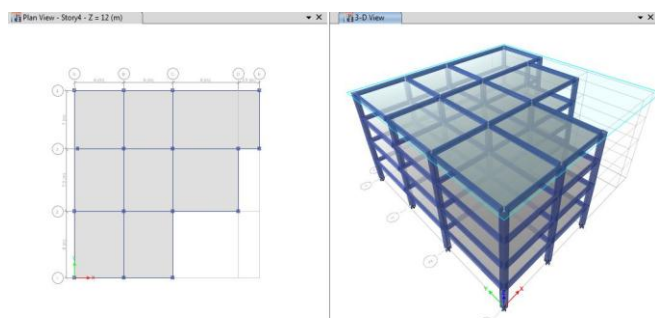

Fig 5 plan and 3-d view of irregular model 3

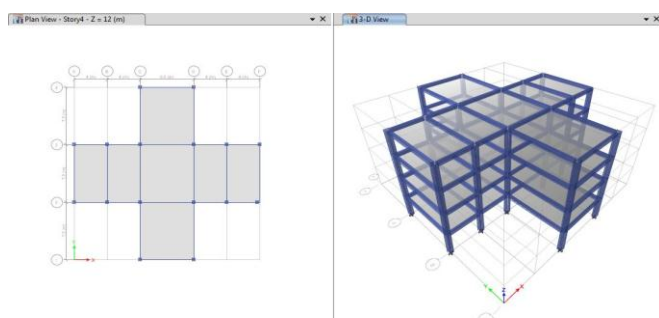

Fig 6 plan and 3-d view of irregular model 4

3.3 CALCULATION OF BASE SHEAR

Using IS: 1893-2002 base shears for the design building was calculated. Percentage of imposed load in seismic weight calculated was taken as 25%. Storey lateral forces and shear forces are calculated and tabulated in the following table:

Table 1 lateral forces and storey shear forces

Floor level	W_i (KN)	H_i (m)	$W_i \times h_i^2$ (kN-m ²)	Storey forces $Q_i = \frac{W_i h_i}{\sum W_i h_i} V_B$	Storey shear forces [V _i]
4	2793.5	12	402264	426.53	426.53
3	3619	9	293139	310.83	737.35
2	3619	6	130284	138.14	875.80
1	3619	3	32571	34.54	910.03

4. RESULTS AND DISCUSSIONS

Five model of G+3 storey buildings are considered for this study, out of these five models one model with regular frame is considered as reference building and four plan irregular models are derived from the regular building. Structural behavior of both reference building and four plan irregular model buildings due to seismic forces is studied and following results are obtained in terms of SDOF system.

4.1 ECCENTRICITY

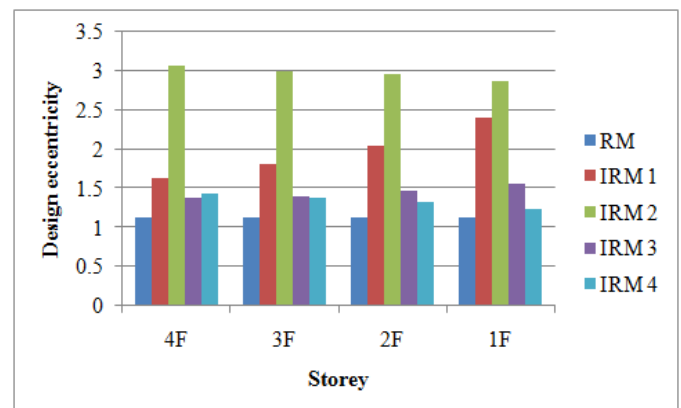

Chart -1: Design eccentricity of all the five models along X-direction

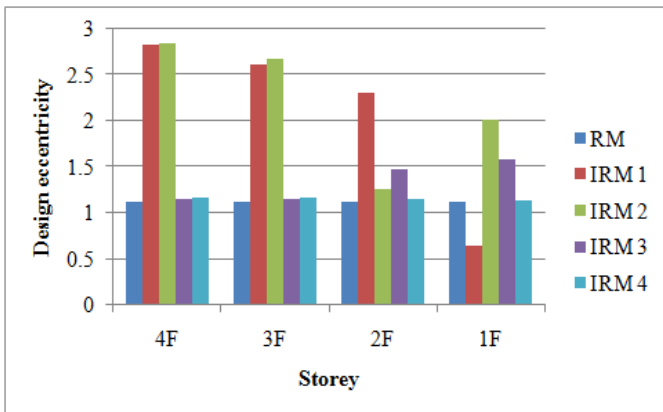

Chart -2 Design eccentricities of all the five models along Y-direction

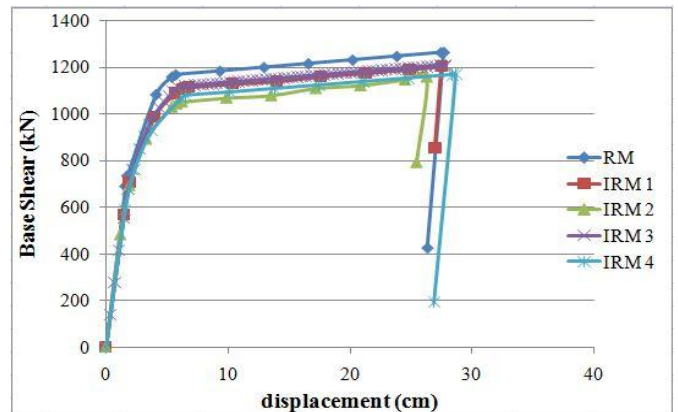

Chart -4 capacity curves of all the models along Y- direction

Table 2 Eccentricity details of all the five models

L E V E L S	RM		IRM 1		IRM 2		IRM 3		IRM 4	
	e_{dix}	e_{di_y}	e_{di_x}	e_{di_y}	e_{di_x}	e_{di_y}	e_{di_x}	e_{di_y}	e_{di_x}	e_{di_y}
4F	1.1	1.1	1.6	2.8	3.0	2.8	1.3	1.1	1.4	1.1
3F	1.1	1.1	1.8	2.6	2.9	2.6	1.4	1.1	1.3	1.1
2F	1.1	1.1	2.0	2.3	2.2	1.2	1.4	1.1	1.3	1.1
1F	1.1	1.1	2.3	0.6	2.2	2.0	1.5	1.1	1.2	1.1

Table 3 Capacity curve details

Model s	RM	IRM 1	IRM 2	IRM 3	IRM 4
Capacity Along X-Direction					
Max base shear in kN	1212.67	1224.83	1215	1438.84	1453.97
Disp (cm)	23.30	23.64	25.39	23.25	25.84
Capacity Along Y-Direction					
Max base shear in (kN)	1263.27	1204.17	1157.11	1208.55	1169.79
Disp (cm)	27.69	27.51	26.31	27	28.73

Design eccentricity at i^{th} floor $e_{di} = 1.5e_{si} + 0.05b_i$

e_{si} = static eccentricity at i^{th} floor

b_i = floor plan dimension of i^{th} floor, perpendicular to the direction of force.

4.2 CAPACITY CURVES OF SDOF MODELS

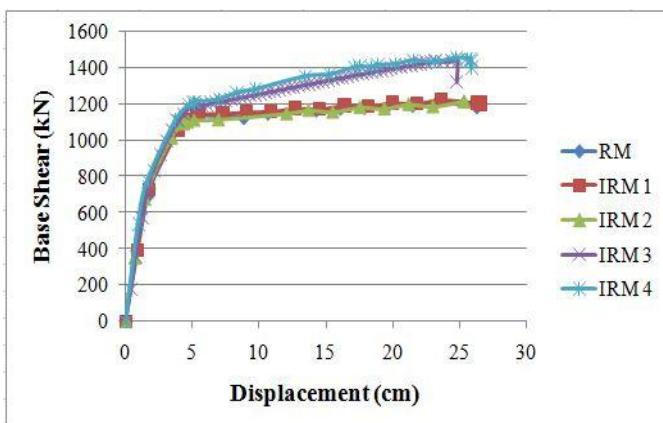

Chart -3: Capacity curves of all the models along X-direction

4.3 STOREY DRIFT

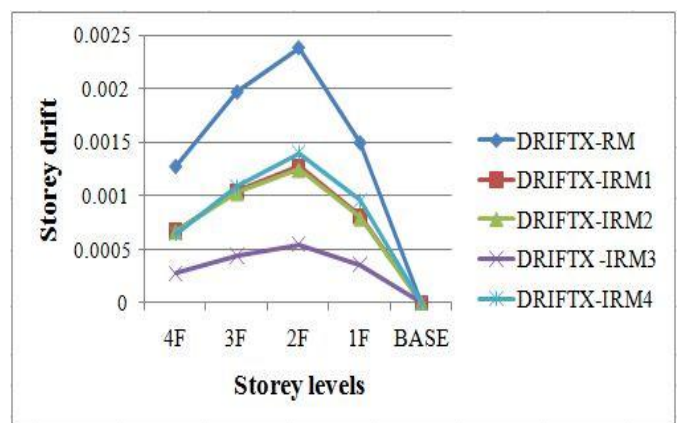

Chart -5 Storey levels vs. storey drift along X-direction

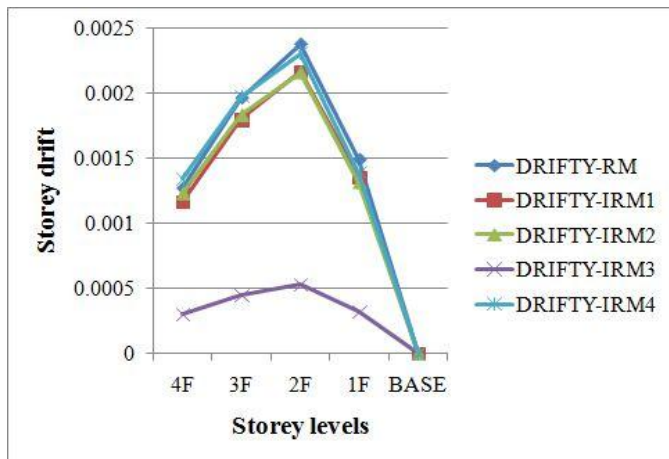

Chart -6 Storey level vs. storey drift curve along Y-direction

4.4 STOREY DISPLACEMENT

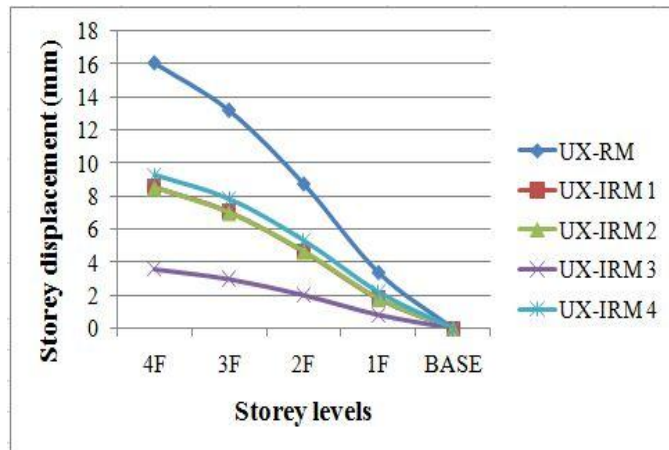

Chart -7 Storey level vs. Storey displacement along X-direction

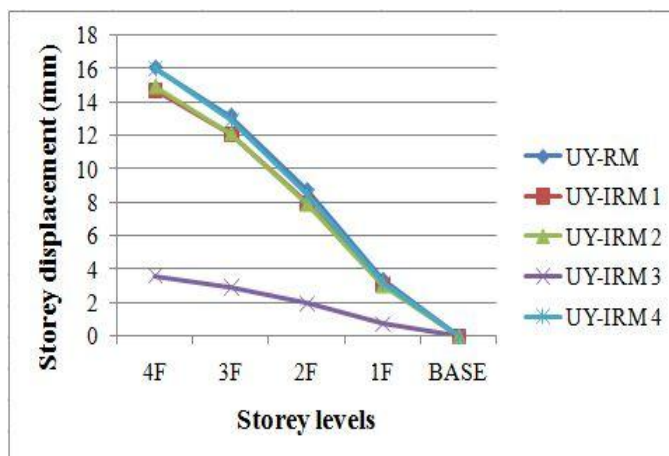

Chart -8 Storey level vs. storey displacement along Y-direction

Table 4 Performance point of building along X and Y direction of all the model

models	RM	IRM 1	IRM 2	IRM 3	IRM 4
PERFORMANCE POINT OF BUILDING IN X-DIRECTION					
Fy (kN)	1060.3	1060	1047.4	1098.5	1096.5
Dy (cm)	2.48	2.56	2.155	2.41	2.12
T* (sec)	0.95	0.88	0.8	0.85	0.7
Sa (g)	0.123	0.1630	0.1627	0.1703	0.2179
Sd (cm)	23.3	23.63	21.27	21.95	15.53
PERFORMANCE POINT OF BUILDING IN Y-DIRECTION					
Fy (kN)	1091.9	1031.03	971.5	1047	982.3
Dy (cm)	2.6	2.73	2.55	2.79	2.6
T* (sec)	0.962	0.92	0.9	0.94	0.82
Sa (g)	0.129	0.1553	0.157	0.150	0.191
Sd (cm)	23.83	25.16	23.63	25.16	21.95

Fy - Yield strength

Dy - Yield displacement

$T^* = 2\pi[(m \cdot D_y) / F_y]^{1/2}$ sec

Sa - Spectral acceleration

Sd - Spectral displacement

3. CONCLUSIONS

- Eccentricity occurs due to irregularity in plan, more irregularity leads more torsional problem that forces the whole structure to deflect beyond its deflection limit and causes failure of structure. IRM 3 shows very less eccentricity compared to other models in both X and Y direction due to less irregularity in plan.
- Non-linear pushover analysis serves as a basic tool for determining strength of the structure in the expressions of base shear and roof displacement when displacement based approach is used. Along X-direction all the five models shows less displacement corresponding to their maximum base shear. Since maximum base shear with less displacement the structure is vulnerable along X direction due to more irregularity and less ductility along X direction.

- The intersection point of capacity spectra and demand spectra is known as performance point. The RM shows same value of maximum S_a with maximum S_d in both direction due to its symmetry. IRM2 and IRM4 shows maximum S_a with minimum S_d in both the direction, that means these model is not capable to resist higher base shear at longer time due to its irregularity.
- Displacing of one storey with respect to top or lower storey due to seismic movement called storey drift. The drift values of all the models are within permissible limit according to IS 1893-2002 i.e., $0.004 \times H$ where H is the height of the storey.
- If a building with less displacement indicates more stiffness in the structure. Storey displacement increases along the height of the structure. RM shows maximum displacement along both the directions and strengthened IRM 3 shows the less displacement along both the directions indicates more stiffness in IRM 3 and less stiffness and more flexibility in RM.
- The non-linear failure of structural components can be easily estimated by using non-linear hinge models prescribed by FEMA 356. The nonlinear hinge bar charts for all the five models, maximum number of nonlinear hinges formed at life safety performance level indicates structure still have some strength to bear the lateral effects.
- Finally by studying the results of all the parameters obtained from analysis we conclude that, the performance of RM is good in all the parameters due to its symmetric nature. IRM1 and IRM3 shows reasonable seismic response due to less plan irregularity but IRM2 and IRM4 models are not good in seismic response due to more plan irregularity, which require more torsional stiffness.

of RC buildings". Earthquake Resistance Engineering Structures v. WIT Transactions on the built environment, Vol 81.

- [5] [5] **Dr. Mayank Desai, Darshit Jasani** (2015): "Application of nonlinear static pushover procedure to the displacement based approach of seismic analysis of G+10 storey building structure for Indian terrain". IJRSI. Vol II, Issue VII, ISSN 2705.
- [6] [6] **Prof. Milind V. Mohod** (2015): "Pushover analysis of structures with plan irregularity". IOSR Journal of Mechanical and Civil engineering. e- ISSN: 2278-1684, p-ISSN: 2320-334X, Volume 12, pp 46-55.
- [7] [7] **Neethu K. N., Saji K. P.** (2015): "Pushover analysis of RC building". International Journal of science and research, ISSN : 2319-7064.
- [8] [8] **Chetan S. Patil** (2016): "Non-linear static analysis of structure for planer irregularity". Indian Journal of applied research 667. Vol: 6, ISSN-2249-555X.
- [9] [9] **D.N. Shinde, Nair Veena V, Pudale Yojana M** (2014): "Pushover analysis of multy storey building". International Journal of research in engineering and technology. Vol: 3.

BIOGRAPHIES



Swathi B S is M. Tech 4th semester Scholar in BGSIT, B.G.Nagar, Mandya, Karnataka, India



Mrs. Manjula K. is Assistant Professor in BGSIT, B.G.Nagar, Mandya, Karnataka, Inda.



Mrs. Punith P. R is Assistant Professor in BGSIT, B.G.Nagar, Mandya, Karnataka, Inda.

REFERENCES

- [1] [1] **Peter Fajfar, M. EERI** (2000): "A nonlinear analysis method for performance based seismic design". Earthquake Spectra, Vol. 16, No. 3, pp 573-592, Jamova 2, SI1000 Ljubljana, Slovenia.
- [2] [2] **S.C. Pendnekar, H. S. Chore, S. B. Patil** (2015): "Pushover analysis of reinforced concrete structures". International conference on Quality Up- grading in engineering, science and Technology (ICQUEST2015).
- [3] [3] **Dini Devassy Menachery, Manjula N. K** (2014): "Application of extended N2 method to reinforced concrete frames with asymmetric setbacks". International Journal of Civil Engineering and Technology (IJCIET). Volume 5, Issue 12, pp 143-154.
- [4] [4] **P. P. Diotallevi, L. Landi** (2005): "On the pushover analysis as a method for evaluating the seismic response