

# “Design of different stroke double cylinder lever operated knapsack sprayer”

S.S.Dandge<sup>1</sup>, Dr.D.S.Ingole<sup>2</sup>

<sup>1</sup>Research Scholar, Department of Mechanical Engineering, Prof. Ram Meghe Institute of Technology & Research, Badnera, Amravati, Maharashtra.

<sup>2</sup> Professor, Department of Mechanical Engineering, Prof. Ram Meghe Institute of Technology & Research, Badnera, Amravati, Maharashtra.

\*\*\*

**Abstract** - The present lever operated sprayer relates to the design of a different stroke double cylinder lever operated knapsack sprayer. The design comprises: lever operated knapsack sprayer provided with two cylinders, one is placed inside the tank and other is placed outside the tank. The internal cylinder contains pressure tank itself and in external cylinder is provided with separate removable pressure tank. For upward movement of lever both piston moves downward. Hence in the internal cylinder compression stroke occurs at same time as external cylinder suction stroke occurs. When piston moves down, the compression stroke occurs in the external cylinder, and suction stroke occurs at internal cylinder.

**Key Words:** Farming Sprayers, Agricultural, Ergonomics, Knapsack, DSDC (Different Stroke Double Cylinder) etc...

## 1. INTRODUCTION

The lever-operated knapsack sprayer is a portable unit which is extensively used for farm spraying work. With the appropriate arrangement and assembly of the fittings, it can apply herbicides, insecticides, fungicides and other compounds to the plants. It absolutely permits its application anywhere in the farm where a person can walk, or in the areas inaccessible to vehicle mounted motorized sprayers. Though there are several fuel operated sprayers commercially available in the market, those are less efficient and uneconomical. On the contrary, the DSDC-LOK sprayers are portable, light weight, easy to handle and proves to be economical for wide area spraying as well as for spot spraying. The invented DSDC-LOK shows better result in terms of increasing optimal output, reducing efforts and leads to the increase in efficiency and performance. These facts highlight the importance of developing an efficient and friendly product for the agriculture growers. The present invention intends to substantially enhance the performance and reduce the cost in manufacturing of knapsack sprayers.

The existing knapsack sprayers are not perfectly fit for the purpose due to many reasons and following disadvantages:

1. In existing sprayer models, the ergonomic aspects are not given due attention in design and their ease of operation. Hence, the man-equipment system performance observed to be poor, resulting in the lower output.
2. In the existing sprayer models, due to the postural discomfort, a back pain problem arises along with the muscular disorder.
3. The existing sprayer models require more strokes to develop a required pressure; i.e. the more strokes are required for fine droplet discharge.
4. In the existing sprayer models, the volumetric efficiency is comparatively less.
5. The existing sprayer models require a lot of physical effort and the operator has to actuate the lever by one hand at a frequency of 15 to 20 strokes per minute. This is almost a continuous process the operator has to perform in order to develop the requisite pressure for spraying work.
6. The existing models of backpack sprayer can't maintain a requisite pressure and it results in the drifts/dribbling. Because of this, the wastage of spraying fluid takes place and cost of spraying increases.

### 1.1 Advantages of DSDC-LOK Sprayer

1. The DSDC-LOK Sprayer considers ergonomic aspects in sprayer design and operation. It ensures the comfort in spraying, decreases postural discomfort and safeguard operator's health.
2. The several ergonomic principals are applied for optimal designing of lever operated sprayer, which gives better interaction between human and product.
3. The DSDC-LOK Sprayer produces a steady stream of spray materials in the desired fineness of the particles so that the plants to be treated covers uniformly.
4. The DSDC-LOK Sprayer delivers liquid with sufficient pressure. This causes liquid to reach to all the foliage and spreads entirely over the sprayed surface.
5. The DSDC-LOK Sprayer has two cylinders.

Because of using two cylinders with different strokes, the increase in pressure built up inside the tank is ensured and the strokes required to create a requisite pressure has been reduced. The operator requires comparatively less effort and he can spray comparatively larger area with minimum effort.

6. Higher pressure is built up inside the pressure tank than the conventional single cylinder and single stroke sprayers.
7. The sprayer model is suitable for treating large areas as well as the small areas such as nurseries, greenhouses and vegetable gardens.

## 2. DETAILED DESCRIPTION OF SPRAYER

This DSDC-LOK Sprayer relates to a sprayer for spraying herbicides, insecticides, fungicides and other compounds. This sprayer consists of operating lever (A), liquid tank (B), Internal piston and cylinder arrangement(C), delivery hose (D),external pressure chamber (E),external piston and cylinder arrangement (F), base of sprayer (G),connecting rod (H) and the spray lance with nozzle (I). The pump of the sprayer is actuated by working a hand lever up and down by one hand of the operator and the other hand holds the cut off device for spraying purpose. The sprayer is to be carried on the back of the operator with help of a pair of mounting straps. The sprayer has a liquid discharge arrangement with flow rate adjustment to be held in one hand of the operator and an operating handle arranged to be operated by the other hand of the operator. This makes possible for operator to operate the handle with either hand when required.

The double cylinder different stroke LOK sprayer consists of a tank and two cylinders of which one is external mounted and other is internally mounted. It also consists of a lever, a pressure chamber, a lance with an on-off trigger valve and the nozzle. Second cylinder is directly operated by a lever. To operate the first cylinder the connecting rod is used. one end of connecting rod is attached to first cylinder and other end is attached to lever rod. Here lever rod is extended by welding a bar at the inclined position. The connecting rod is attached to extended bar of lever and first cylinder by clamp and bolt arrangement. Initially the spray liquid is filled in the tank; the pressure chamber is occupied by air at atmospheric pressure.

When the lever (A) moves up, both cylinders pistons move down, which means a suction stroke occurs at second cylinder (F) and compression stroke occurs at the first cylinder(C), which means that different strokes occur at both the cylinders. During this suction stroke certain

volume of liquid is drawn through the valve into the respective pump cylinder.

When the lever moves down, the both cylinders and pistons move up, which means that a compression stroke occurs at second cylinder (F) and suction stroke occurs at first cylinder(C).

During this compression stroke at respective cylinder, liquid in the pump cylinder is forced past through valve into the pressure chamber. The suction valve between the pump and tank is closed during this operation to prevent return of the liquid back into the tank. Air is trapped in upper portion of the pressure chamber and compressed as liquid forced into the pressure chamber. The discharge for both the cylinder is different. To connect the outlet of both the cylinder to same lance (I) the hose (D) is used. The hose (D) is connecting to T-pipe and this T-pipe is connected at one end of outlet of second cylinder and at another end to spray lance (I).

When the operator opens trigger in the lance, the compressed air forces liquid from the pressure chamber to flow past the valve, through the lance and exit through the nozzle(into atmosphere) as a spray.

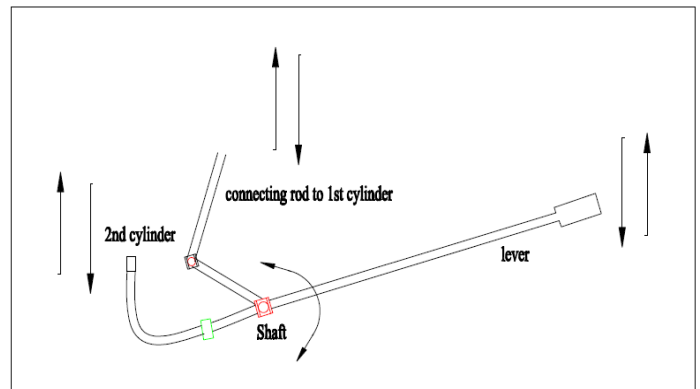

Figure 1: Lever mechanism for different stroke DSDC-LOK sprayer

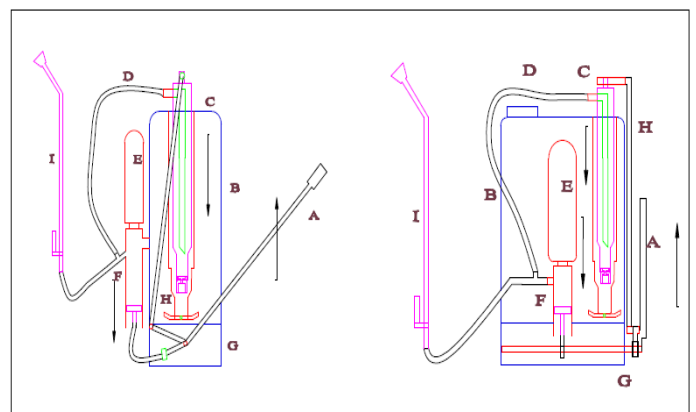
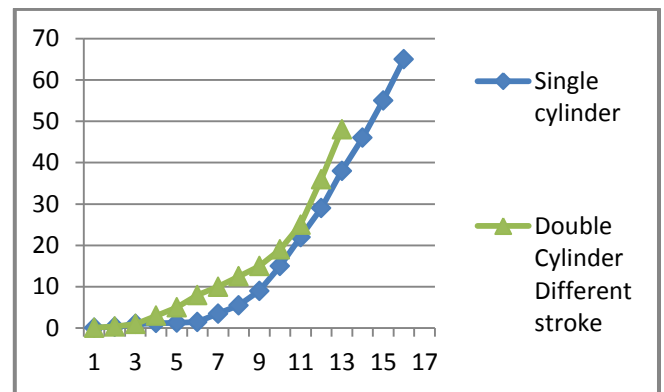

Figure 2: Side & front views of different stroke DSDC-LOK sprayer

Where,

- A- Lever
- B- Main body
- C- First piston and cylinder arrangement (internal Type)
- D- Hose
- E- Pressure tank for external cylinder
- F- Second piston and cylinder arrangement (External Type)
- G- Base for sprayer
- H- Connecting Rod
- I- Spray lance



**Graph-1:** Pressure Vs Number of Stroke  
(Pressure (Psi) on Y-Axis & No Of Stroke On X-Axis)

### 3. PRELIMINARY TRIALS ON LOK SPRAYER

#### 3.1 Procedure for pressure Vs number of strokes study

Each sprayer was mounted on a test rig and filled with clean water up to its full capacity. A pressure gauge of 0 to 7 kgf/ cm<sup>2</sup> range was fitted in the lance just before the controlling valve (trigger). A Subject operated the handle lever giving full stroke each time, The pressure built up in the number of strokes were observed. The same procedure is applied for all three types of sprayer. Twelve replication were taken.

**Table-1:** Pressure Vs Number of Stroke

Sr. no	no. of Stroke	Pressure (Psi)	
		Single cylinder	Double Cylinder Different stroke
1	1	0.1	0.1
2	2	0.3	0.4
3	3	1	1
4	4	1.2	3
5	5	1.3	5
6	6	1.5	8
7	7	3.5	10
8	8	5.5	12.5
9	9	9	15
10	10	15	19
11	11	22	25
12	12	29	36
13	13	38	48
14	14	46	
15	15	55	
16	16	65	

#### 3.2 Procedure for discharge vs number of strokes study

Each sprayer was mounted on a test rig and filled with clean water up to its full capacity. A Subject operated the handle lever giving full stroke each time, The discharge for each trial were observed. The same procedure is applied for all three types of sprayer. Twelve replication were taken.

**Table-2:** Discharge Vs Number of Stroke

Sr. no	no. of Stroke	Discharge (ml)	
		Single cylinder	Double Cylinder Different stroke
1	1	50	90
2	2	120	180
3	3	200	270
4	4	250	400
5	5	300	520
6	6	350	600
7	7	400	630
8	8	430	690
9	9	470	770
10	10	500	830
11	11	610	920
12	12	710	1050
13	13	735	1270
14	14	770	
15	15	800	
16	16	830	

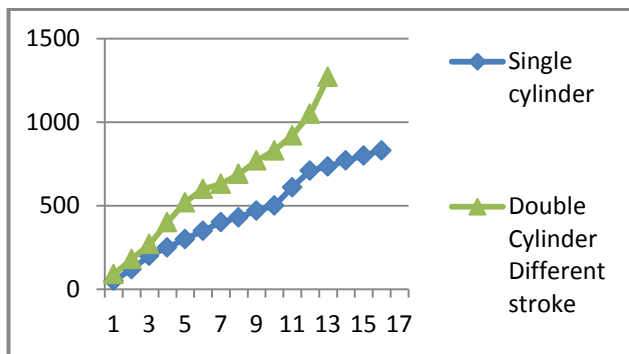

**Graph-2:** Discharge Vs Number of Stroke  
(Discharge (ml) on Y-Axis & No Of Stroke On X-Axis)

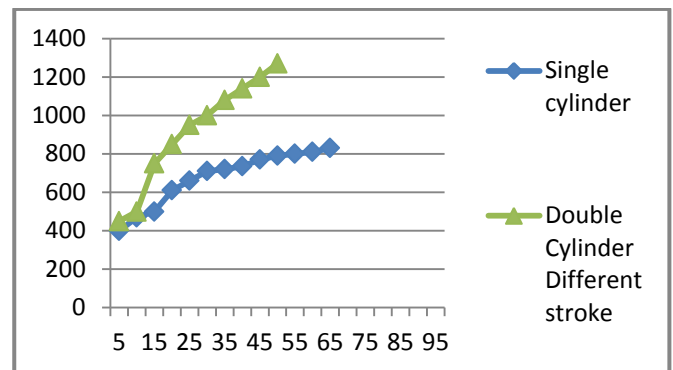

**Graph-3:** Pressure (Psi) Vs Discharge (ml)  
(Discharge (ml) on Y-Axis & Pressure (Psi) On X-Axis)

### 3.3 Procedure for discharge vs pressure relationship

This test was carried out as per the procedure specified in IS 10134-1982 ( Indian Standard on methods for manually operated sprayers each sprayer was fitted with a pressure gauge. sprayer mounted on the rig and filled to its full capacity with water. A Subject operated the lever to maintain the desire pressure and discharge was measured.

**Table-3:** Discharge Vs Pressure

Sr. no	Pressure (psi)	Discharge (ml)	
		Single cylinder	Double Cylinder Different stroke
1	5	400	450
2	10	470	500
3	15	500	750
4	20	610	850
5	25	660	950
6	30	710	1000
7	35	720	1080
8	40	735	1140
9	45	770	1200
10	50	790	1270
11	55	800	
12	60	810	
13	65	830	

### 4. CONCLUSIONS & FUTURE SCOPE

After completing need of problem, collection of relevant data, fabrication of model and taking successful trial, conclusions are drawn which are as follows:

#### 4.1 CONCLUSIONS

From the trial taken on the fabricated model we come to conclusion that spraying can be done efficiently with the help of double cylinder sprayer with slightly higher input power from the operator. The pump can deliver the liquid at higher pressure than single cylinder alone, so that it reaches all the foliage and spreads entirely over the sprayed surface. It is slightly higher in weight yet sufficiently strong, easily workable and repairable. It is economical therefore affordable for all kind of farmers. It requires comparatively less time for spraying so we can get more fields spraying per day. It is cost effective than the existing spraying pumps available in the market as no operating cost (fuel cost or cost for maintenance of animal) is needed.

#### 4.2 Future scope

The both the cylinder double cylinder same stroke and double cylinder different stroke is fabricated and operated successfully. Still there is a scope to do some modifications, which will make it more effective. So as the weight is increased in the modified sprayer in the future it can be possible that to reduce the weight of cylinder by taking the cylinder of another material which is sufficiently strong and have higher durability and also in the future we can use both the cylinder of same type internal or external so that the constriction of sprayer is much simpler than existing, slightly different mechanism needed to operate these cylinder

## REFERENCES

1. R. Joshua, V. Vasu and P. Vincent (2010) "Solar Sprayer - An Agriculture Implement", International Journal of Sustainable Agriculture 2 (1): 16-19, 2010 ISSN 2079-2107"
2. R. D. Fox, R. C. Derksen, (2003)"Visual and image system measurement of spray deposits using water-sensitive paper" Applied Engineering in Agriculture Vol. 19(5): 549-552 2003 American Society of Agricultural Engineers ISSN 0883-8542
3. Bindra O. S., (1971) Testing of plant protection equipment; establishment of central test house - laying of standards etc. paper presented in first group discussion held at (PPTI) Hyderabad from Feb. 26-28.
4. Bindra O. S. & Singh H. (1971) Pesticides application equipment; Oxford and IBH Publication Company.
5. BIS, (1982) (Part -I) Specification for hand operated knapsack sprayer - piston type. IS - 3906 (part- I) 1982 Bureau of Indian Standard, New Delhi.
6. Burger G. C. E. (1969) Heart rate and concept of circulatory load. Ergonomics 12(6): 857-864.
7. Bush J. C. et al., (1988) Influence of dynamic factors on the lumbar spine movement in lifting Ergonomics 31(2):211-216.
8. Corlett & Bishop. (1976) suggested a technique for assessing the postural discomfort.
9. De A. & Sen R. A., (1986) Ergonomic evolution of ploughing process of paddy cultivation in India , General of Human Ergology 15(3): 103-112.
10. Fisher H. H. & Deutsch, (1985) Lever Operated Knapsack Sprayer IPPC document no 53-A-84, USA.
11. Garg C. L. (1990) Standardization and Performance evaluation of agricultural sprayers; paper presented at Industrywise Conference on pest control equipment held at C.I.A.E., Bhopal on 22 February, 1990.
12. Ghugare B. D. Adhoo, S. H, Gite, L. P; Pandya . A.C. and Patel, S. L. (1991) Ergonomic evaluation of a lever operated knapsack sprayer ; Applied Ergonomics. 22 (4): 241-250.
13. Gite L. P. & Yadav B. G. (1986) Instrumentation for measurement of human effort, energy expenditure and instrumentation for testing of agricultural machinery. Technical Bulletin NO. CIAE/IDP/86/1 C.I.A.E. Bhopal.
14. Gite L. P. & Pandya A.C. (1989). Test code and procedure for ergonomic evaluation of a lever operated knapsack sprayer. A draft proposal Central Institute of Agricultural Engineering, Bhopal India
15. Gite L.P. & Pandey, M.M. (1992) A setup for simulation of force application on the handle of LOK Sprayer. Central Institute Of Agricultural Engineering Bhopal.
16. Harrison M. H. et al., (1982) the oxylog - An evolution Ergonomics 25(9): 809-820.
17. Kroemer K.H.E., (1970) Human strength terminology measurement and interpretation of data human factors 12(3) :643-653.
18. Matthews G.A. & Knight A.A., (1969) Ergonomics in agricultural equipment design, National Institute of Agril. Engg. Silsoe U. K.
19. Matthews G.A. & Thornhill E., (1989) Sprayer testing at Britain's JPARC, Portable spraying machinery 1988-89, Imperial college of silwood Park Ascot. U. K.
20. Morehouse L.E., (1959) Strength of human factor 1(2): 43-48.
21. Murrell K.H.F., (1979) Ergonomics- Man in his working environment. Chapman and Hall, London.
22. Nag p. k. et al., (1980) Occupational workload of Indian agriculture workers; Ergonomics, 23(2):91-102.
23. Sastry V.C.S., (1971) Testing of plant protection equipment at testing centres. Paper presented at first group discussion at CPPTI. Hyderabad from Feb. 26-28
24. Sengupta A.K. & Sarkar D. N., (1979) Mukhopadhyay and Goswami D. C. Relationship between pulse rate and energy expenditure during graded work at different temperatures; Ergonomics, 22(11) 1207-1215.
25. Singh, H. & Kaul. R. N., (1972) Human energy requirements of selected farm operations. J. of Agril. Engg. 9(3) : 44- 52.
26. Suggs C. W. & Splinter W. E., (1958) Time and energy analysis of agricultural tasks: Trans ASAE 1; 50-52.
27. Sutherland J. A., (1979) The evaluation of knapsack sprayers and motorized knapsack sprayers; PANS, 25 (3): 332-364.
28. Sutherland, J. A., (1987) Procedures for the comparative evaluation of knapsack sprayers natural resource institute, London, UK.
29. Wely P.V., (1970) Design and diseases , applied Ergonomics 1(5) : 262 -269.
30. Chao A, Kumar A, Nagarajrao K and You H, (2000) "An Ergonomic evaluation of Cleco Pliers", HFES 2000 Congress, 444-442.
31. Dewangan K., Owary C. and Datta R., (2008) "Anthropometric data of female farm workers from north eastern India and design of hand tools of the hilly region", International Journal of Industrial Ergonomics, 38, 90-100,



## BIOGRAPHIES



1) Shrikant S. Dandge  
[B.E.,M.E.,M.B.A.,Ph.D.(App.)]  
Research Scholar, Department of  
Mechanical Engineering, Prof.  
Ram Meghe Institute of  
Technology & Research, Badnera,  
Amravati, Maharashtra.



2) Dr. Dilip S. Ingole  
[B.E.,M.Tech.,M.B.A.,Ph.D.]  
Professor,Department of  
Mechanical Engineering, Prof.  
Ram Meghe Institute of  
Technology & Research, Badnera,  
Amravati, Maharashtra.