

IMPROVING EFFICIENCY OF ACTIVE POWER FILTER FOR RENEWABLE POWER GENERATION SYSTEMS BY USING PREDICTIVE CONTROL METHOD AND FUZZY LOGIC CONTROL METHOD

T PRAHLADA¹, P SUJATHA², P BHARATH KUMAR³

¹PG Scholar, Dept. Of Electrical & Electronics Engineering, JNTUACEA, Anantapuramu, A.P., India

² Professor, Dept. Of Electrical & Electronics Engineering, JNTUACEA, Anantapuramu, A.P., India

³ Lecturer, Dept. Of Electrical & Electronics Engineering, JNTUACEA, Anantapuramu, A.P., India

Abstract- In this paper, an active power filter was implemented with a four-leg voltage-source inverter using a concept of predictive control along with fuzzy logic controller was presented. Here we are using fuzzy logic controller instead of using other controllers. The utilization of a four-leg voltage-source inverter allows the compensation of current harmonic components, as well as unbalanced current generated by single-phase nonlinear loads. A fuzzy controller is designed to mitigate the total harmonic distortion. Under steady state and transient operating conditions, the proposed active power filter compensation performance and the control strategy associated was demonstrated through simulation results. The simulation was done by using MATLAB/Simulink software.

social progress, it's necessary to fulfill the energy need by utilizing the renewable energy resources like wind, biomass, hydro, co-generation, etc. In sustainable energy system, energy conservation and also the use of renewable source are the key paradigm. The necessity to integrate the renewable energy like wind energy/PV into power system is to create it possible to reduce the environmental impact on typical plant. The integration of wind energy into existing power system presents technical challenges which need consideration of voltage regulation, stability, power quality issues. The power quality is a vital customer-focused measure and is greatly tormented by the operation of a distribution and transmission network.

Index Terms—Active power filter, current control, four-leg converters, predictive control, Fuzzy logic controller.

I. INTRODUCTION

Increasing global energy consumption and noticeable environmental pollution are creating renewable energy more necessary. Today, a small percentage of total global energy comes from renewable sources, primarily hydro and wind power. Renewable generation affects power quality because of its nonlinearity, since solar generation plants and wind power generators should be connected to the grid through high-power static PWM converters [1]. The non-uniform nature of power generation directly affects voltage regulation and creates voltage distortion in power systems. This new situation in power distribution systems would require additional sophisticated compensation techniques.

However, these dg units produce a wide range of voltages because of the fluctuation of energy resources and impose rigorous necessities for the inverter topologies and controls. To have sustainable growth and

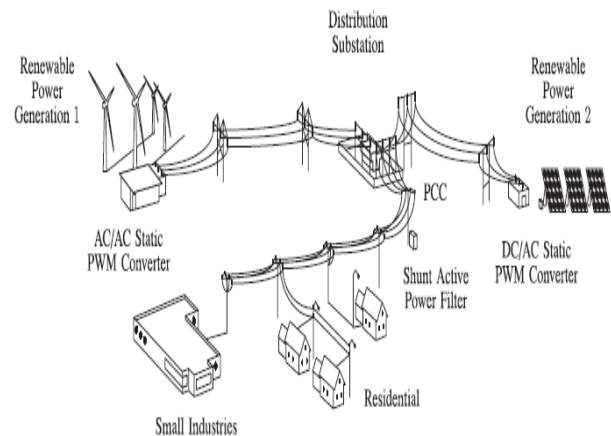

Fig. 1(a). Stand-alone hybrid power generation system with a shunt active power filter

Renewable sources, like wind and sunlight, are generally used to generate electricity for residential users and little industries. Both kinds of power generation use ac/ac and dc/ac static PWM converters for voltage conversion and battery banks for long run energy storage. These converters perform maximum power point tracking to extract the maximum energy attainable from wind and sun. Fig. 1(a) shows the configuration of a typical power

distribution system with renewable power generation. It consists of various kinds of power generation units and differing kinds of loads. Although active power filters enforced with three-phase four-leg voltage-source inverters (4L-VSI) have already been presented within the technical literature [2]–[6]. An correct model obtained mistreatment predictive controllers improves the performance of the active power filter, particularly throughout transient operating conditions, as a result of it will quickly follow the current-reference signal whereas maintaining a constant dc-voltage.

However recently there are several researchers reported with success adopted fuzzy logic Controller (FLC) to become one amongst intelligent controllers to their appliances. With reference to their successful methodology implementation, this type of methodology enforced in this paper is using fuzzy logic controller with feedback by introduction of voltage severally. The introduction of modification in voltage within the circuit is going to be fed to fuzzy controller to give acceptable measure on steady state signal. The fuzzy logic controller is intelligent controller for this proposes. This paper presents the mathematical model of the 4L-VSI and therefore the principles of operation of the projected predictive control scheme, as well as the design procedure. Finally, the proposed active power filter and therefore the effectiveness of the associated control scheme compensation, power quality improvement is simulated using Matlab/ Simulink.

PI CONTROLLER

A proportional–integral controller (PI controller) could be a control loop feedback mechanism (controller) normally employed in industrial control systems. A PI controller continuously calculates an error value $e(t)$, $e(t)$ because the difference between a desired set point and a measured method variable and applies a correction supported proportional and integral terms (sometimes denoted P and i respectively) that provide their name to the controller kind.

A PI controller continuously calculates an error value $e(t)$, $e(t)$ because the difference between a desired set point and a measured method variable and applies a correction supported proportional, integral, and derivative terms. The controller makes an attempt to reduce the error over time by adjustment of a control variable $u(t)$, like the position of a control valve, a damper, or the ability equipped to a element, to a new value determined by a weighted sum:

$$U(t) = k_p e(t) + k_i \int_0^t e(t) dt$$

The proportional term produces an output value that's proportional to the present error value. The proportional response will be adjusted by multiplying the error by a constant K_p , known as the proportional gain constant.

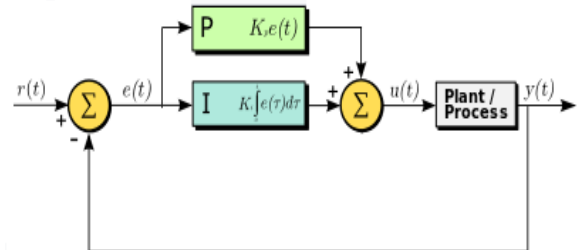

Fig. 1(b). PI controller

The contribution from the integral term is proportional to each the magnitude of the error and therefore the duration of the error. The integral during a PID controller is that the add of the instantaneous error over time and provides the accumulated offset that ought to be corrected previously. The accumulated error is then multiplied by the integral gain (K_i) and added to the controller output.

Here , we are using PI controller in current reference generator , when filtering the error voltage by using low pass filter we are applying it to the PI controller it provides the ability reference signal ie.

II.MODELING OF FOUR-LEG CONVERTER

The consumption of electrical energy is random and unpredictable behavior, and thus, it ought to be single- or three-phase, balanced or unbalanced, and linear or nonlinear. At the point of common coupling, an active power filter is connected in parallel to compensate current harmonics, current unbalance, and reactive power. It's composed by an electrolytic capacitor, a four-leg PWM converter, and a first-order output ripple filter, as shown in Fig. 2. This circuit considers the power system equivalent impedance Z_s , the converter output ripple filter impedance Z_L , and the load impedance Z_L .

The Fig. 3 shows the four-leg PWM converter topology. This converter topology is analogous to the traditional three-phase converter with the fourth leg connected to the neutral bus of the system. The fourth leg will increase switching states from 8 (2^3) to 16 (2^4), improving control flexibility and output voltage quality, and is appropriate for current unbalanced compensation.

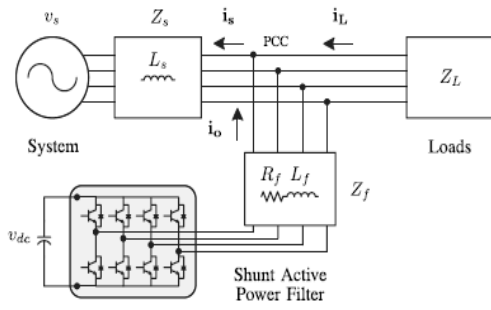

Fig. 2. Three-phase equivalent circuit of the proposed shunt active power filter

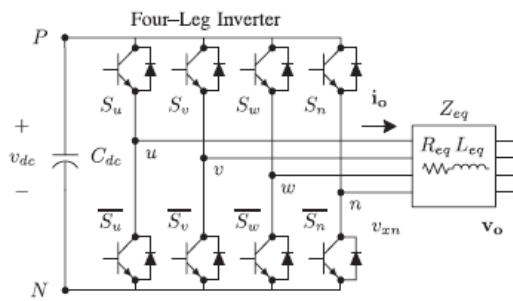

Fig. 3. Two-level four-leg PWM-VSI topology

The voltage in any leg x of the converter, measured from the neutral point (n), can be obtained in terms of the switching states, as follows:

$$v_{xn} = S_x - S_n v_{dc}, x = u, v, w, n \quad (1)$$

The mathematical model of the filter derived from the equivalent circuit shown in Fig. 2 is

$$V_0 = v_{xn} - R_{eq} i_0 - L_{eq} \frac{di_0}{dt} \quad (2)$$

Where R_{eq} and L_{eq} are the 4L-VSI output parameters expressed as Thevenin impedances at the converter output terminals Z_{eq} . Therefore, the Thevenin equivalent impedance is determined by a series combination of ripple filter impedance Z_f and a parallel arrangement between the system equivalent impedance Z_s and the load impedance Z_L

$$Z_{eq} = \frac{Z_s Z_L}{Z_s + Z_L} + Z_f \approx Z_s + Z_f \quad (3)$$

For this model, it is assumed that $Z_L \gg Z_s$, that the system's equivalent impedance resistive part is neglected, and that the series reactance is in the range of 3-7% p.u., which is an acceptable approximation of the real system. Finally, in (2) $R_{eq} = R_f$ and $L_{eq} = L_s + L_f$.

III. CONTROL STRATEGY DIGITAL PREDICTIVE CURRENT CONTROL

The block diagram of the proposed digital predictive current control theme is shown in Fig. 3. This control theme is essentially an optimization algorithm and, therefore, it's to be enforced in a microprocessor. Consequently, the analysis should be developed using separate mathematics so as to consider extra restrictions like time delays and approximations.

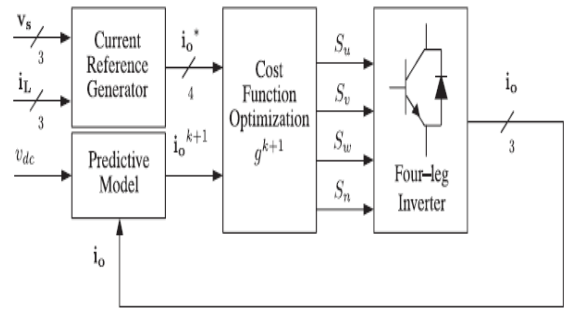

Fig. 4. Proposed predictive digital current control block diagram

The main characteristic of predictive control is that the use of the system model to predict the future behavior of the variables to be controlled. The predictive control algorithm is simple to implement and to know, and it are often enforced with 3 main blocks, as shown in Fig. 4.

(A) Current Reference Generator: This unit is meant to get the desired current reference that's used to compensate the undesirable load current parts. During this case, the system voltages, the load currents, and also the dc-voltage converter are measured, whereas the neutral output current and neutral load current are generated directly from these signals.

(B) Prediction Model: The converter model is employed to predict the output converter current. Since the controller operates in separate time, each the controller and also the system model should be represented in a very discrete time domain. this implies that for a given sampling time T_s , knowing the converter switching states and control variables at instant kT_s , it is possible to predict the next states at any instant $[k+1]T_s$. Owing to the first-order nature of the state equations that describe the model in (1)-(2), a sufficiently correct first-order approximation of the derivative is taken into account during this paper

$$\frac{dx}{dt} \approx \frac{x[k+1] - x[k]}{T_s} \quad (4)$$

(C) Cost Function Optimization: In order to select the optimal switching state that must be applied to the power converter, the 16 predicted values obtained for $i_o[k + 1]$ are compared with the reference using a cost function g , as follows:

$$g[k + 1] = (i_{ou}^*[k + 1] - i_{ou}[k + 1])^2 + (i_{ov}^*[k + 1] - i_{ov}[k + 1])^2 + (i_{ow}^*[k + 1] - i_{ow}[k + 1])^2 + (i_{on}^*[k + 1] - i_{on}[k + 1])^2 \quad (5)$$

The output current (i_o) is capable the reference (i_o^*) when $g = 0$. Therefore, the optimization goal of the cost operate is to attain a g value near zero. Throughout every sampling state, the switching state that generates the minimum value of g is chosen from the 16 attainable operate values. The algorithm selects the switching state that produces this nominal value and applies it to the converter throughout the $k + 1$ state.

CURRENT REFERENCE GENERATION

A dq-based current reference generator theme is employed to get the active power filter current reference signals. This theme presents a quick and correct signal tracking capability. This characteristic avoids voltage fluctuations that deteriorate the present reference signal moving compensation performance. the present reference signals are obtained from the corresponding load currents as shown in Fig. 5.

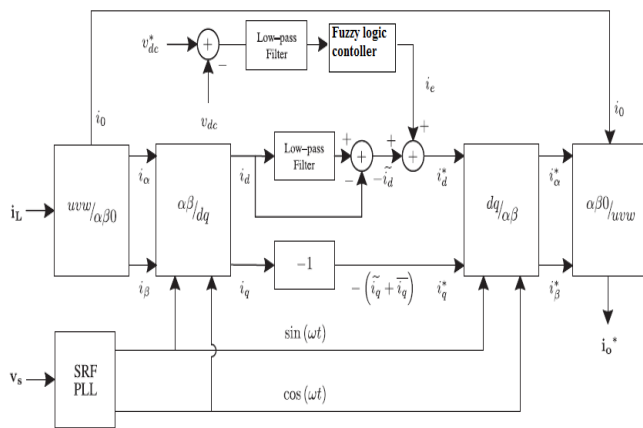

Fig. 5.dq-based current reference generator block diagram

This module calculates the reference signal currents needed by the converter to compensate reactive power, current harmonic and current imbalance. The displacement power factor ($\sin \phi_{(L)}$) and the maximum total harmonic distortion of the load ($THD_{(L)}$) defines the relationships between the apparent power needed by the active power filter, with regard to the load, as shown

$$\frac{S_{APF}}{S_L} = \frac{\sqrt{\sin \phi_{(L)} + THD_{(L)}^2}}{\sqrt{1 + THD_{(L)}^2}} \quad (6)$$

Where the value of $THD_{(L)}$ includes the maximum compensable harmonic current, defined as double the sampling frequency f_s . The frequency of the maximum current harmonic component that can be compensated is equal to one half of the converter switching frequency.

The dq-based theme operates during a rotating reference frame; so, the measured currents should be increased by the $\sin(\omega t)$ and $\cos(\omega t)$ signals. By using dq-transformation, the d current part is synchronized with the corresponding phase-to-neutral system voltage, and therefore the q current part is phase-shifted by 90° . The $\sin(\omega t)$ and $\cos(\omega t)$ synchronized reference signals are obtained from a synchronous reference frame (SRF) PLL. The SRF-PLL generates a pure sinusoidal waveform even once the system voltage is severely distorted. Following errors are eliminated, since SRF-PLLs are designed to avoid phase voltage unbalancing, harmonics (i.e., less than 5% and 3% in fifth and seventh, respectively), and offset caused by the nonlinear load conditions and measurement errors.

IV. SIMULATION RESULTS

A simulation model for the three-phase four-leg PWM converter with the parameters shown in Table-2 has been developed exploitation MATLAB-Simulink. the target is to verify the present harmonic compensation effectiveness of the projected control theme under completely different operational conditions. A six-pulse rectifier was used as a nonlinear load. The projected predictive control formula was programmed exploitation an S-function block that permits simulation of a separate model that may be simply implemented during a real-time interface (RTI) on the dSPACE DS1103 R&D control board. Simulations were performed considering a 20 [μs] of sample time.

TABLE 2: SPECIFICATION PARAMETER

Variable	Description	value
v_s	Source voltage	55v
F	System frequency	50Hz
V_{dc}	dc voltage	162v
L_f	Filter inductor	5 mH
C_{dc}	dc capacitor	2200μF
R_f	Internal resistance with R_f	0.6Ω
T_s	Sampling time	20μs
T_e	Execution time	16μs

Note: $v_{base}=55V$ and $S_{base}=1KVA$

In the simulated results shown in Fig. 14, the active filter starts to compensate at $t = t_1$. At now, the active power filter injects an output current i_{ou} to compensate current harmonic parts, current unbalanced, and neutral current at the same time. Throughout compensation, the system currents authority show sinusoidal waveform, with low total harmonic distortion (THD = 3.93%). At $t = t_2$, a three-phase balanced load step change is generated from 0.6 to 1.0 p.u. The compensated system currents stay sinusoidal despite the change within the load current magnitude. Finally, at $t = t_3$, a single-phase load step change is introduced in phase u from 1.0 to 1.3 p.u., that is admire an 11 November current imbalance. of course on the load aspect, a neutral current flows through the neutral conductor (i_{Ln}), however on the supply aspect, no neutral current is determined (i_{sn}). Simulated results show that the projected control theme effectively eliminates unbalanced currents. Additionally, Fig. 8 shows that the dc-voltage remains stable throughout the entire active power filter operation.

4.2 MATLAB MODEL

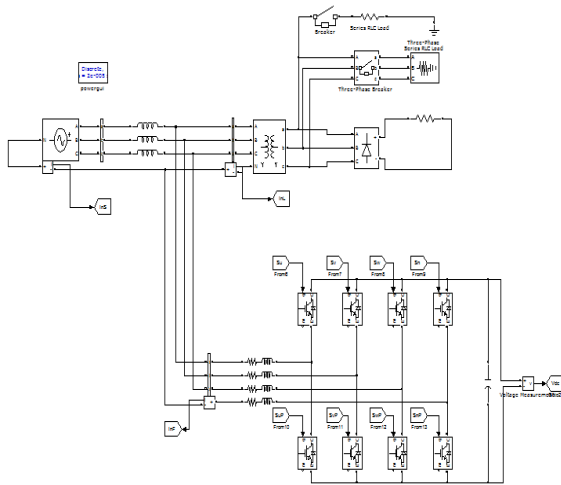

Fig. 8. Matlab model of proposed system

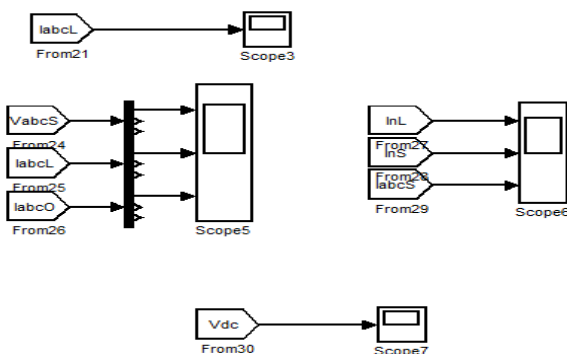

Fig. 9. Scopes for output waveforms

4.3 CONTROL CIRCUITS

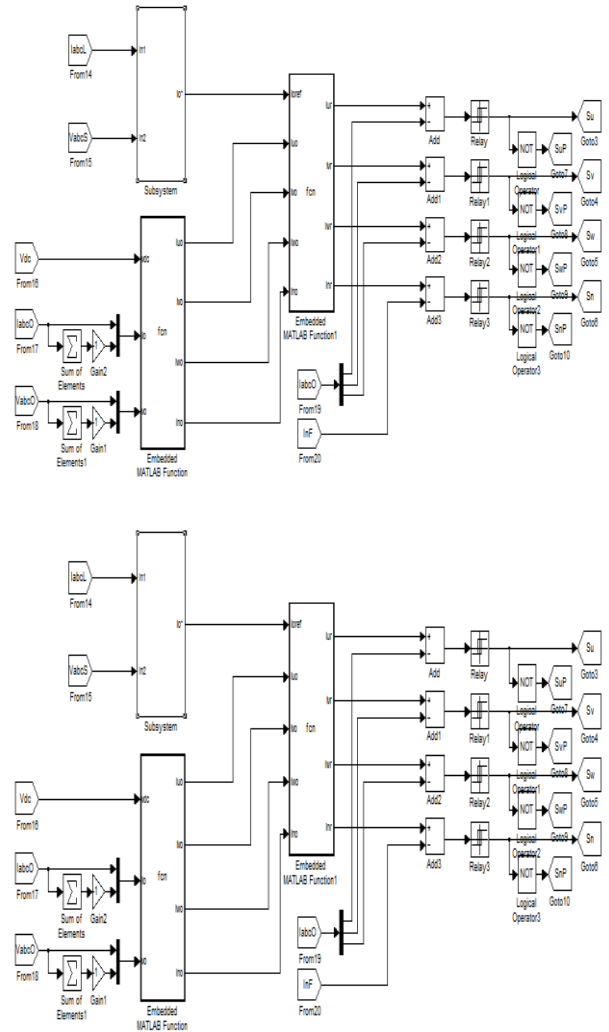

Fig. 10. Matlab model for control circuit algorithm

4.3.1. With PI controller

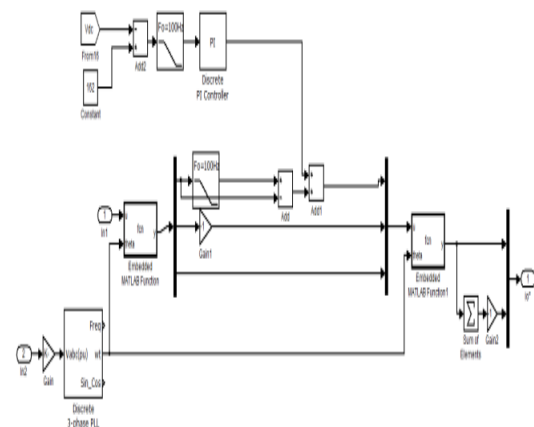

Fig. 11. Control circuit with PI controller

4.3.2. With fuzzy logic controller

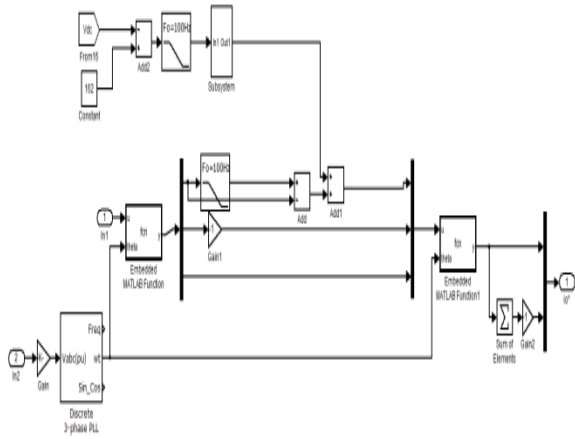

Fig. 12. Control circuit with fuzzy logic controller

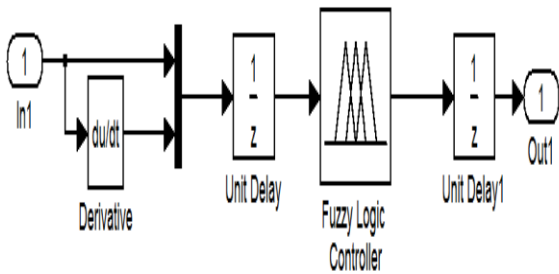

Fig. 13. Fuzzy logic controller

4.4 MATLAB RESULTS

4.4.1. With PI controller

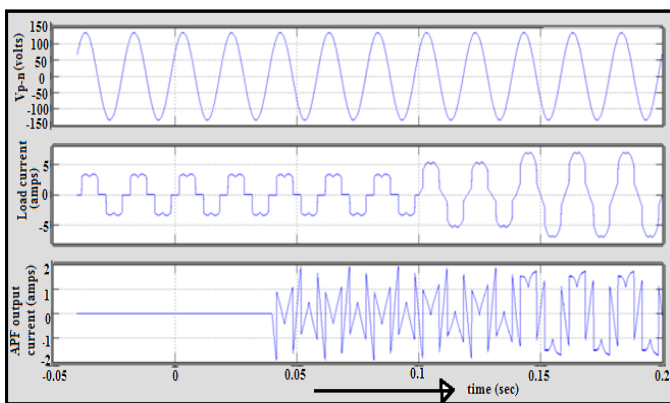

Fig. 14(a). Simulated waveforms of the proposed control scheme. (i) Phase to neutral source voltage. (ii) Load Current. (iii) Active power filter output current.

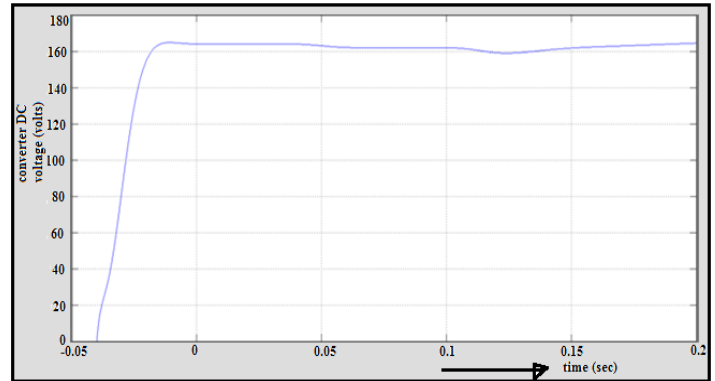

Fig. 14(b). Simulated waveforms of the proposed control scheme. (i) DC voltage converter.

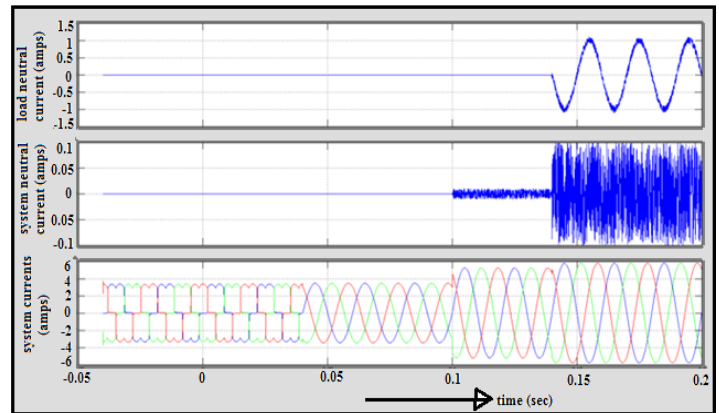

Fig. 14(c). Simulated waveforms of the proposed control scheme. (i) Load neutral current. (ii) System neutral current. (iii) System currents.

4.4.2. With fuzzy logic controller

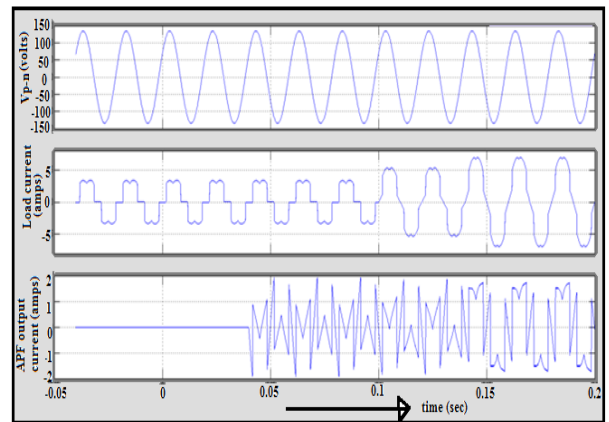

Fig. 15(a). Simulated waveforms of the proposed control scheme. (i) Phase to neutral source voltage. (ii) Load Current. (iii) Active power filter output current.

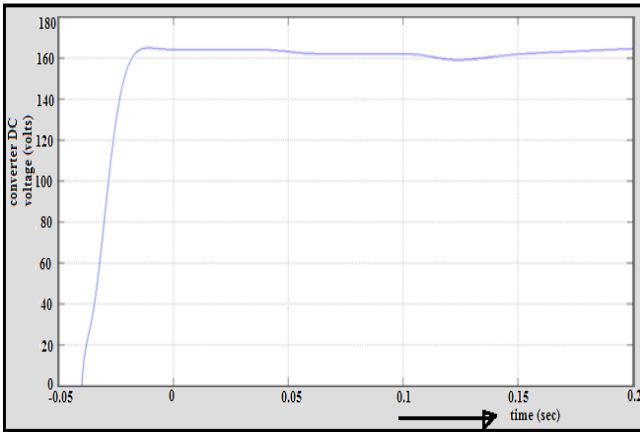

Fig. 15(b). Simulated waveforms of the proposed control scheme. (i) DC voltage converter.

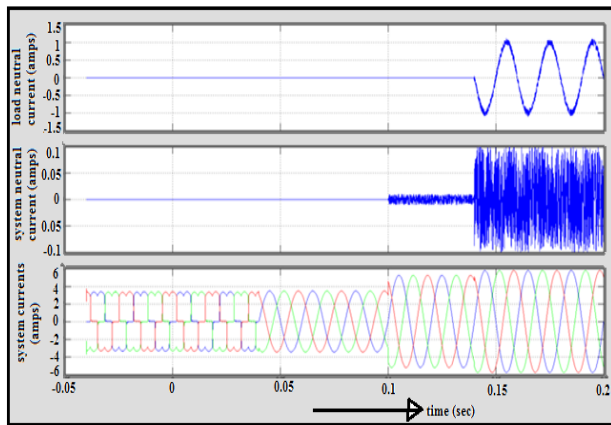
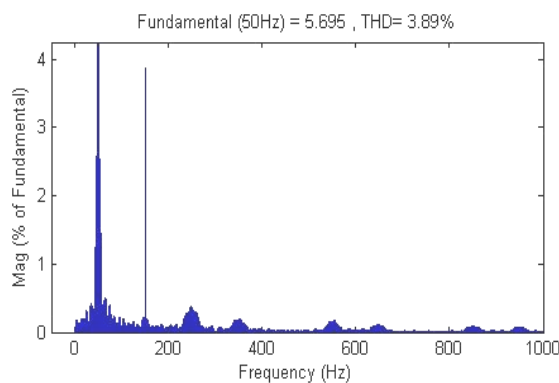

Fig. 15(c). Simulated waveforms of the proposed control scheme. (i) Load neutral current. (ii) System neutral current. (iii) System currents.

V. THD Results Comparison:

With PI controller:



With Fuzzy Logic Control:

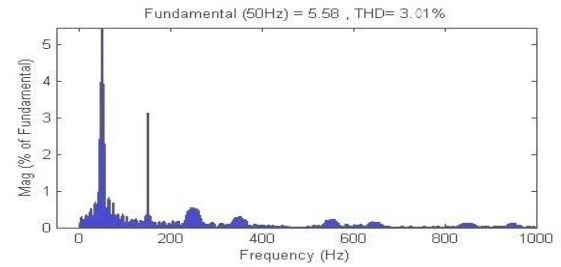

Threshold Harmonic Distortion (THD) value of the System current (i_s) decreased to 3.01% by using fuzzy logic compared to 3.89% by using PI controller.

VI. CONCLUSION

Dynamic current harmonics Improvement and a reactive power compensation theme for power distribution systems with generation from renewable sources have been planned to boost this quality of the distribution system. Advantages of the planned theme are associated with its simplicity, modeling, and implementation. The employment of a predictive control algorithm for the converter current loop tried to be an efficient resolution for active power filter applications, improving current following capability, and transient response. Simulated results have tried that the planned predictive management algorithm is also a good varied to classical linear management ways. The predictive current control algorithm is also a stable and robust answer. Total harmonic distortion was reduced by using fuzzy controller in comparison to PI controller. Simulated results have shown the compensation effectiveness of the proposed active power filter. The simulation was done by using Matlab/Simulink software.

REFERENCES

- [1] J. Rocabert, A. Luna, F. Blaabjerg, and P. Rodriguez, "Control of power converters in AC microgrids," *IEEE Trans. Power Electron.*, vol. 27, no. 11, pp. 4734–4749, Nov. 2012.
- [2] M. Aredes, J. Hafner, and K. Heumann, "Three-phase four-wire shunt active filter control strategies," *IEEE Trans. Power Electron.*, vol. 12, no. 2, pp. 311–318, Mar. 1997.
- [3] S. Naidu and D. Fernandes, "Dynamic voltage restorer based on a fourleg voltage source converter," *Gener. Transm. Distrib.*, IET, vol. 3, no. 5, pp. 437–447, May 2009.
- [4] N. Prabhakar and M. Mishra, "Dynamic hysteresis current control to minimize switching for three-phase four-leg VSI topology to compensate nonlinear load," *IEEE Trans. Power Electron.*, vol. 25, no. 8, pp. 1935–1942, Aug. 2010.