

# Design of Automatic Smart Medication Dispenser

Piyush R.Pawar<sup>1</sup>, Shubham S. Kaikade<sup>2</sup>

<sup>1,2</sup>Department of Electronics & Telecommunication Engineering, Prof. Ram Meghe College of Engineering & Management, Bandera Road, Amravati (444602), Maharashtra, India.

\*\*\*

**Abstract** – To take the medicine at the age in time. The smart medication reminder is designed specially for users who take medicine without any help. It avoids to take wrong medicine at wrong time. It is also useful for blind people. The components required for design of smart medication reminder are raspberry pi zero W (core type- ARM1176JZF-S) interface with LCD16x4, buzzer, led, alarm module (DS3231), multiple pill container and stepper motor. Firstly switch on the kit and the device get asked to set the time for alarm and similarly set for the next alarm putting the pill into pill box and it get close. As the user set the time for alarm the buzzer gives the sound and also blinking the led present in the pill box separately.

By using raspberry pi zero W the interfacing is very easy and simple. The software is used for programming is pycharm and the language is used for programming is python.

**Key Words:** Raspberry pi zero W, Stepper motor, container.

## 1. INTRODUCTION

Senior citizen always face the health care problem and it required to take the medicine daily this device help for those people having a regular health care problem. Today's in our society most families are nuclear that's why children's does not help to there parents. The children's are busy in their personal life.

Though this device is helpful for live in individual family. A pill dispenser, is a good solution, in order to reduce medication errors. This dispenser covers up to 4daily drug doses in a week. Besides classical pill boxes, there are also automatic pill boxes with timer and alarm. An automatic pill box can be a good choice in order to save time and to avoid forgetting to take the medication at the right time, but are more expensive. The health recovery process can be improved by using a programmable medication dispenser.

## 2. LITERATURE SURVEY

We have done the survey till know this medication dispenser is only made for common people , but not made for blind people who can't see, so this system is helpful for both peoples like normal people and blind people also. And it reminds its users to take correct medicines on time.

## 3. DESIGN CONSIDERATIONS

To take the several consideration before starting the design process. The designs of medicine box consideration are the device has rectangular shape having three compartments for pill and capsule. The stepper motor is used for to lock the compartment cover cap it will not open all the compartment simultaneously at a time only one compartment will be opened. An LED display is to be provided to indicate the working condition and to provide pertinent instructions. Microcontroller interface with LED, Stepper motor, alpha numeric keypad, LCD display and speaker is to be designed. Provision for visual and audio notifications is to be provided. Proper storage is to be ensured for quality of medicine.

## 4. HARDWARE

### 4.1 Raspberry pi zero w:

The Pi Zero W has all the functionality of the original Pi Zero but with added connectivity.

- 802.11 b/g/n wireless LAN.
- Bluetooth 4.1.
- Bluetooth Low Energy (BLE).

Like the Pi Zero, it also has:

- 1GHz, single-core CPU.
- 512MB RAM.
- Mini HDMI and USB On-The-Go ports.
- Micro USB power.
- HAT-compatible 40-pin header.
- Composite video and reset headers.
- CSI camera connector.

### 4.2 LCD Display (16x4):

This is a 16 character by 4 line display that runs at 5.0V. Black text on Green background. Includes yellow LED backlight. Utilizes the common SPLC780D(Superior to KS0066U) parallel interface.

### Features:

- High quality STN 16x2 character LCD.
- Yellow LED Backlight.
- 5x8 dot characters.

- SPLC780D controller.
- 1/16 duty cycle.

**Dimensions:** 0.57 x 2.3 x 3.4" (14.5 x 60 x 87mm).

#### 4.3 RTC (DS3231):

The DS3231 is a low-cost, extremely accurate I2C real-time clock (RTC) with an integrated temperature-compensated crystal oscillator (TCXO) and crystal. The device incorporates a battery input, and maintains accurate timekeeping when main power to the device is interrupted. The integration of the crystal resonator enhances the long-term accuracy of the device as well as reduces the piece-part count in a manufacturing line.

#### 4.4 Vibrator:

Electromechanical components known as vibrators were used in a circuit similar to modern solid state inverter circuits to provide a pulsating DC which could be converted to a higher voltage with a transformer, rectified, and filtered to create higher-voltage DC. This "vibrator" is essentially a relay using normally closed contacts to supply power to the relay coil, thus immediately breaking the connection, only to be reconnected very quickly through the normally closed contacts. It happens so rapidly it vibrates, and sounds like a buzzer. This same rapidly pulsing contact applies the rising and falling DC voltage to the transformer which can step it up to a higher voltage.

#### 4.5 Pill Container:

It is made from cardboard having a three compartment in that one. It having such kind of arrangement that led will blink inside that compartment and we will have to take the medicine from that compartment.

#### 4.6 keyboard:

In computing, a computer keyboard is a typewriter-style device which uses an arrangement of buttons or keys to act as a mechanical lever or electronic switch. Following the decline of punch cards and paper tape, interaction via teleprinter-style keyboards became the main input device for computers.

#### 4.7 Speaker:

The Speaker is provided to give a beep sound to warn the patient regarding the time to take the tablet. The same speaker is also use to call the name of the patient which provides the information regarding the updating the pills/capsules into the container. This facility helps the blind to interact with AMD.

### 5. BLOCK DIAGRAM:

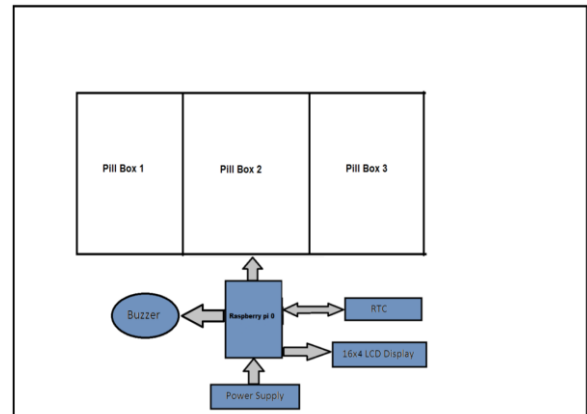

**Fig -5.1:** Block Diagram of Dispenser.

We have taken three pill box and we have done interfacing with raspberry pi zero with the help of program in pi zero, now the source code will help the user to set the time, date, and medicine name. Whatever time the user has set at that time the alarm and led will blink at that particular pill box and also vibrator will vibrate. if the patient forget to take the medicine the snooze function also provide to take that medicine again after 10 to 15 minutes later. Considering the patient is blind at that case the system will gives an alarm and it will vibrate the particular box then the blind patient will sense the vibration and it will take medicine only from that box other box will be lock with the help of stepper motor and it will not open. By using this step the patient can easily get the medicine from the system. So it is helpful for all the people.

### 6. FLOWCHART:

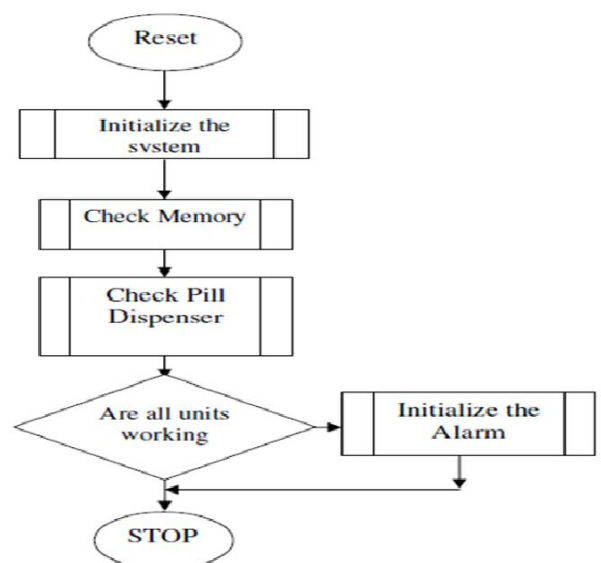

**Fig -6.1:** Initialize the system.

## CONCLUSIONS AND FUTURE SCOPE

The Design of Automatic Smart Medication Dispenser is working for pills and capsules of any size. It has been found that the dispenser can be programmed for 1 month for different medicines. It has the facility to send alarms three times a day. It can also set number of times the alarm in day. It is possible programmable to dynamically change the number of times and the number of pills to be picked as per requirement.

- The end goal is not to develop any new technologies associated with current manufactured dispensers.
- Rather, the goal is to design a unit with the same basic functionality, but for a much cheaper price.
- If the medicine is not taken by the patient then at that case the SMS will come on the cell phone and it will show the required medicine is not taken and user will be alert and it will take the medicine.



Shubham S. Kaikade pursuing Final year in the year 2018. He is in Prof. Ram Meghe College of Engineering & Management, Bandera Road, Amravati in the department of Electronics & Telecommunication Engineering.

## REFERENCES

- [1] "Med-e-lert Medication Pill Box Reminder Dispenser", <http://www.amazon.com/Med-E-Lert-Medication-Pill-Reminder-Dispenser/dp/B0029K03I8>
- [2] "Alarm Pill Box Pill Mate Event Reminder", <http://www.amazon.com/Alarm-Pill-Mate-Event-Reminder/dp/B000R3EETI>
- [3] Mei-Yeing Wang, "A Mobile Phone Based Medicine In-take Reminder and Monitor", 9th IEEE International Conference, June 2009.
- [4] Mei-Ying Wang, John K. Zao Wedjat: A Mobile Phone Based Medication Reminder and Monitor.
- [5] Kuperman GJ, Bobb A, Payne TH, et al. "Medication Related Clinical Decision Support in Computerized Provider Order Entry Systems: A Review" Journal of American Medical Informatics Association, 2007.
- [6] Liu JWS, Shih CS, Tsai PH, Yeh HC, Hsiu PC, Yu CY, Chang WH, "End-User Support for Error Free Medication Process," Proceedings of High-Confidence Medication Device Software and Systems, pp. 34 – 45, June 2007.

## AUTHORS



Piyush R. Pawar pursuing Final year in the year 2018. He is in Prof. Ram Meghe College of Engineering & Management, Bandera Road, Amravati in the department of Electronics & Telecommunication Engineering.