

# ZIGBEE BASED PARAMETERS MONITORING AND CONTROLLING SYSTEM FOR INDUCTION MOTOR

Sneha P. Maske<sup>1</sup>, Dhanashri P. Kandalkar<sup>2</sup>, Punam S. Raut<sup>3</sup>, Prof. A. B. Nagdewate<sup>4</sup>

<sup>1,2,3</sup> UG Scholar, Electrical Engineering, DES's COET, Dhamangaon (Rly.), Maharashtra, India

<sup>4</sup> Assistant Professor, Electrical Engineering, DES's COET, Dhamangaon (Rly.), Maharashtra, India

\*\*\*

**Abstract** – Induction motor monitoring is a fast budding online technology for finding embryonic faults. As wired connectivity is hazardous for human being, the wireless monitoring system preferred to avoid faults occurs at the moment of operation. A low priced system for monitoring the parameters such as temperature, current, voltage and speed of Induction Motor as well as controlling the system with wireless ZigBee technology described in this paper. This system uses four sensors to measure the respective parameters of Induction Motor. These measured parameters are sensed by ZigBee coordinator. ZigBee coordinator transfers all these data to the ZigBee End Device which is connected to computer through USB to TTL. By using the computer interfacing with ZigBee module motor can start and stop and system get sheltered.

**Key Words:** Induction Motor, ZigBee Module, Current, Voltage, Speed, Temperature.

## 1. INTRODUCTION

In industrial sector, single phase and three phase power system widely used for domestic, commercial and industrial purpose. Induction motors are easy to design and available at cheap cost, low maintenance, easy to repair and reliable. Although, it is reliable some inexpedient stresses occur in it which results in the failure of induction motor. Therefore, parameters monitoring of an induction motor are use to expose the initial faults.

The necessity for monitoring has increased because of the widespread use of automation and ultimately mitigates the human efforts. This system is used to correct the machine problems before the occurrence of failure. Digital monitoring and classical monitoring are two monitoring techniques. As wired system which is combination of electrical and mechanical monitoring tools is classical monitoring technique. It is also called as traditional monitoring technique. Digital monitoring has various techniques such as microcontroller based protection system but in this system result is not displayed on the screen. In PLC based protection system data neither stored nor exhibit. Digital system is less costly and reduces time for revealing of defects. ZigBee wireless technology is preferred today because it overcomes all drawbacks. ZigBee acquire less power consumption ability with low cost, greater litheness and huge range.

## 2. ZIGBEE TECHNOLOGY

The ZigBee is standard wireless networking and worked on sensor and remote control applications operated on selected location. ZigBee technology assembles on IEEE standard 802.15.4. It has characteristics as follows:

- Less power consumption
- Data rate 250 kbps
- 2.4 GHz Frequencies
- Intermediate two means of broadcast data between controller and sensor.
- It wrap 10-100 meters
- It has Low expenditure

The ZigBee devices consist of three types namely as ZigBee Coordinator, ZigBee Router and ZigBee End Device. ZigBee Coordinator is use to accumulate all the records and PC/Laptop interact with ZigBee with the help of coordinator. ZigBee Router is intermediary device which enlarge the power of signal expected from the coordinator and send to the ZigBee End Device which is convenient device find fresh parent if lost previous one.

Mesh, Star and Cluster Tree are ZigBee Topologies they arrange the essential element of system. Following figure - 2.2 shows the ZigBee Network Topologies.

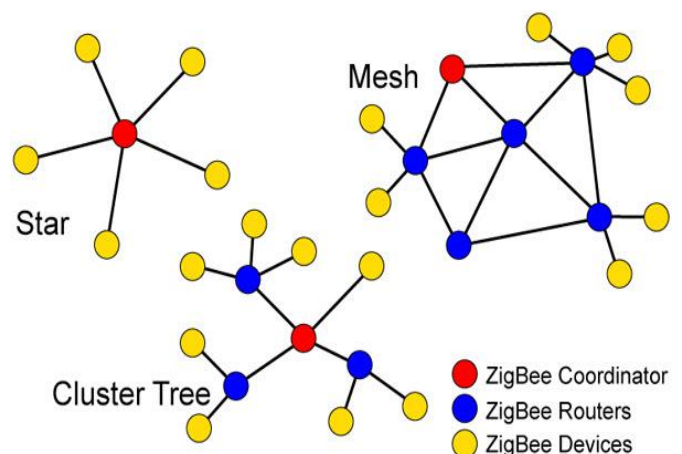

Fig -2.2: ZigBee Network Topology

### 3. THE PROPOSED SYSTEM

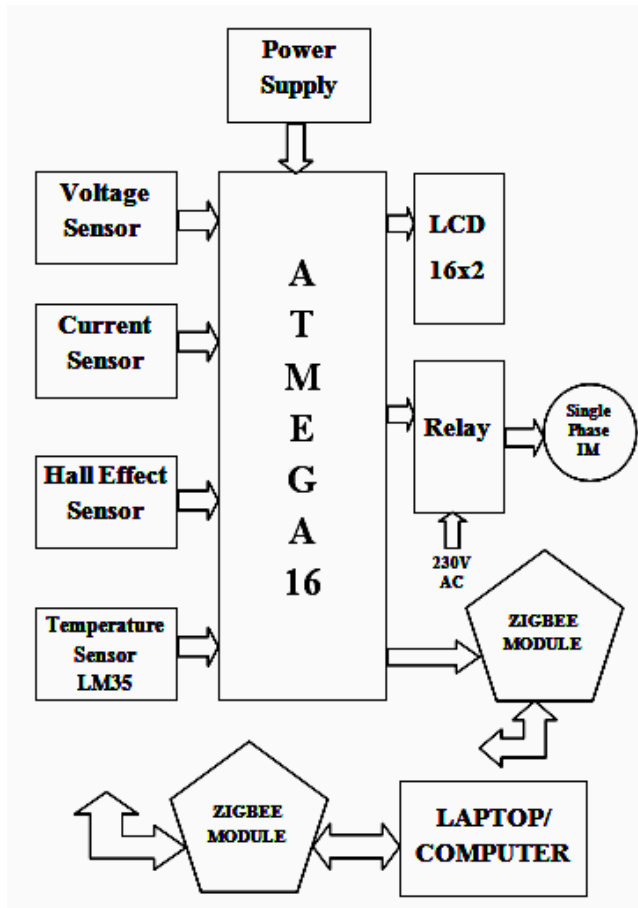

Fig -3: Block Diagram of Proposed System

#### 3.1. Hardware Explanation

The proposed system consists of single phase induction motor, current sensor, voltage sensor, temperature sensor LM35, Hall effect sensor are used to sense the respective parameters and monitor the system and relay is used for controlling the system.

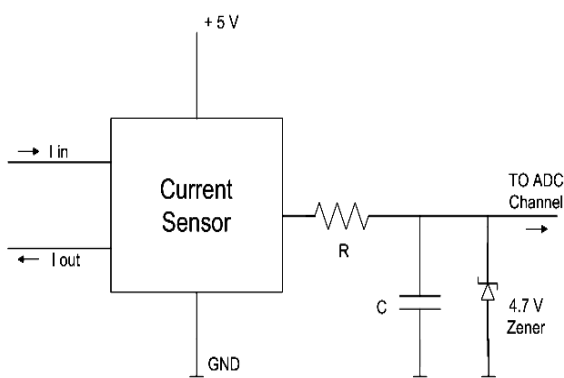

Fig -3.1 (a): Current Measuring Circuit

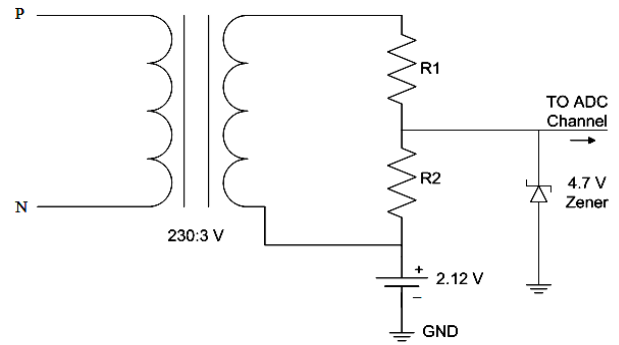

Fig -3.1 (b): Voltage Measuring Circuit

#### 3.2. Software

The Flash Magic is PC tool. It is for programming flash base microcontrollers from NXP via a serial or Ethernet protocol while in objective hardware. Flash Magic software is open source software which installed in PC/Computer. All the parameter monitoring and controlling system are done by using this software. It is uncomplicated and spontaneous user interface as well as it can verify involuntarily after programming. ZigBee End Device is coupled to PC/ Laptop which collect all the records from ZigBee Coordinator and display it on LCD as well as PC/Laptop screen.

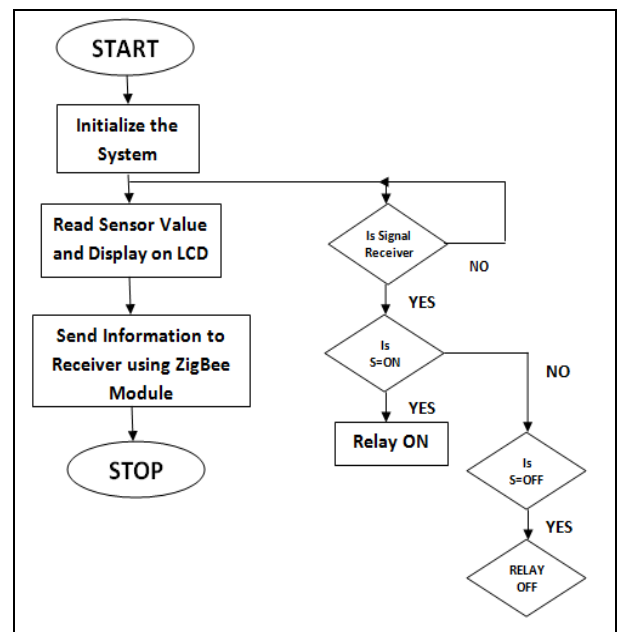

Fig -3.2: A Simplified Flowchart Illustrating the Operational Procedure for Proposed system.

#### 4. RESULT

In this project, parameters of single phase induction motor are monitor as well as control by ON/OFF mechanism with the help of ZigBee Module which supports Wireless Personal Area Network (WPAN).

## 5. CONCLUSION

The proposed system is implemented in Department of Electrical Engineering in Electrical Machine Laboratory at DES'S COET, Dhamangaon (Rly.), (India). During experimental test, no problem has been observed either communicating the ZigBee Protocol to computer or integrating hardware unit used for Parameters monitoring as well as controlling the system. This system used for industrial as well as educational sector.

## 6. FUTURE WORK

In future this can be modified for controlling the parameters of induction motor. The proposed system has limited range due to ZigBee; this can be increase in future using GSM and Wi-Fi, hence increasing the range.

## 7. ACKNOWLEDGMENT

We got this prospect to articulate our appreciation and indebtedness to our guide Ms. A. B. Nagdewate, Assistant Professor, (E & P) Electrical Engineering Department and thankful to those who have directly and indirectly helped for Completion of this paper.

## 8. REFERENCES

- [1] R. R. Patil, T. N. Date, B. E. Kushare., "ZigBee Based Parameters Monitoring System for Induction motor," Department of Electrical Engineering, K. K. Wagh Institute of Engineering Education and Research, Amrut-Dham, Panchavati, Nashik-422003, India.
- [2] Baran L., "A PLC based monitoring and control of power factor of a three phase induction motors," MSc Thesis, Gazi University, Institute of Science and Technology, Ankara, 2009.
- [3] Bayındır, R., Demirbaş, Ş., Irmak, E., Bekiroğlu, E., "Design and implementation of microcontroller based starting and protection relay for induction motors," Journal of Polytechnic, 2007, pp.1-2.
- [4] Daniel Alexandru Vişan, Ioan Liţă, Mariana Jurian and Ion Bogdan Cioc, "Wireless Measurement System Based on ZigBee Transmission Technology," IEEE Transactions on 33rd Int. Spring Seminar on Electronics Technology, 2010.
- [5] Chengbo YU, Yanfei LIU, Cheng WANG, "Research on ZigBee Wireless Sensors Network Based on ModBus Protocol," Wireless Sensor Network, 2009, pp.1-60.