

# BICYCLE SHARING SYSTEM

M. Krishna sai<sup>1</sup>, N. Ajith chowdary<sup>2</sup>, S. Mohith kumar<sup>3</sup>

<sup>1,2,3</sup>Department of Computer Science and Engineering, SRM university, Ramapuram, Chennai.

\*\*\*

**Abstract** - A bicycle-sharing system is a system, or a service in which bicycles are made available for shared use to individuals on a short term basis for a price or free. Bike share systems allow people to borrow a bike from a "dock" and return it at another dock belong to the same system. Docks are special bike racks that lock the bike, and only release it by computer control. The user enters their payment information, and the computer unlocks a bike. When the user returns the bike, they place it in the dock, which locks it into the dock. For many systems, smartphone mapping apps show nearby stations with available bikes and open docks.

**Key Words:** Bicycle Sharing system, Dock, Smart phone, GPS.



Fig -1: Proposed system

## 1. INTRODUCTION

The first bike sharing projects were initiated by local community organisations, or as charitable projects intended for the disadvantaged, or to promote bicycles as a non-polluting form of transport, or they were business enterprises to rent out bicycles. The first documented bike-share project began in Europe in 1965, the group Provo painted fifty bicycles white and placed them unlocked in Amsterdam for everyone to use freely. Bike-sharing systems have developed and evolved with society changes and technological improvements. Many bicycle programmes paint their bicycles in a strong solid colour, such as yellow or white. Painting the bicycles helps to advertise the programme, as well as theft (a painted-over bicycle frame is normally less desirable to a buyer). However, theft rates in many bike-sharing programmes remain high, as most shared-use bicycles have value only as basic transport, and may be resold to unsuspecting buyers after being cleaned and repainted. In response, some large-scale bike sharing programmes have designed their own bike using specialised frame designs and other parts to prevent disassembly and resale of stolen parts.

## 2. PROPOSED SYSTEM

The proposed system also has two kinds of service stations for the bike system, fixed service station and the manual service point. The bicycle has a smart lock attached with a QR code on it. A servo motor is used for lock & unlock purpose. If the user wants to rent a bicycle, he has to download the mobile application, enter the payment information & then scan the QR code through the application. While returning the user has to park the bicycle in its specified dock & lock it back by scanning the QR code.

## 3. SYSTEM ARCHITECTURE

### ARCHITECTURE

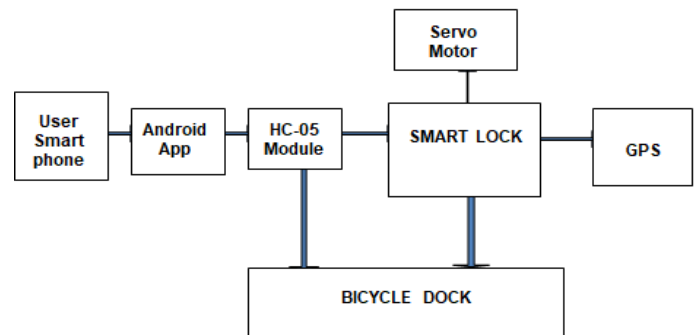

Fig -2: Architecture diagram

## 4. IMPLEMENTATION

The implementation of bicycle sharing system starts with hiring the cycle from dock station by just scanning QR code provided .when the user scans code by filling payment and other necessary details then lock gets unlocked from the dock. Locking is similar to unlocking which can be done by scanning the QR code. A fully automated locking system at stations that allows users to check cycles in or out without the need for staffing at the station. • Radio frequency identification devices (RFIDs) to track where a cycle is picked up, where it is returned, and the identity of the user. • Real-time monitoring of station occupancy rates through General Packet Radio Service (GPRS), used to guide the redistribution of cycles. The user gets notifications about nearest dock stations and also about running time, fare etc through the application.



**Fig -3:** Implementation of project

GPS tracking software. Data tracking software is available for smartphones with GPS capability.



**Fig -4:** GPS tracker

## 5. DESCRIPTION OF MODULES

### 5.1 Dock

Dock is pin like structure which used to connect electronic devices to multiple resources as it carries specific signals which reduces the process of docking through mobile.

### 5.2 Servomotor

A servomotor is a closed loop servomechanism that uses position feedback to control its motion and final position. The input for its control will be either analogue or digital representing the position commanded for the output shaft. The motor is paired with some type of encoder to provide position and speed feedback. In the simplest case, only the position is measured. The measured position of the output is compared to the command position, the external input to the controller. If the output position differs from that required, an error signal will be generated which then causes the motor to rotate, as needed to bring the output shaft to the appropriate position. As the positions approach, the error signal reduces to zero and the motor stops.

### 5.3 Bluetooth module

The Bluetooth module HC-05 is a "MASTER/SLAVE" module. By default the factory setting is "SLAVE". The Role of the module (Master or Slave) can be configured only by at commands. The slave modules cannot initiate a connection to another Bluetooth device, but can accept connections. Master module can initiate a connection to other devices.

### 5.4 GPS tracker

A GPS tracking unit is a navigation device, normally carried by a moving vehicle or person, that uses the Global Positioning System (GPS) to track the device's movements and determine its location. The recorded location data can either be stored within the tracking unit or transmitted to an Internet-connected device using the cellular (GPRS or SMS), radio, or satellite modem embedded in the unit. This allows the asset's location to be displayed against a map backdrop either in real time or when analysing the track later, using

### 5.5 Mobile application

This app helps cyclist to know nearest parking slot and also will show the time consumed and also the required details for the payment as well. Mobile application are created to make the user experience more efficient and useful.



**Fig -6:** Name of the figure

## 6. EXISTING SYSTEM

There are two kinds of service stations for the bike system, fixed service station (standard) and the manual service point (portable terminal with staff). The stations extended the service hire time to 6:30-20:00 and the renting time was extended half an hour. For renting a bicycle, a bike card is needed. In the SCB system, there are two types of bike cards, seasonal cards and 3-days cards. The card is "smart card" which utilizing NFC- near field communication technology.

## 7. RESULT

The arrival of dockless bike shares had created a positive impact in the growth of cycling sharing. In Australia estimated that 1.5 kilograms of CO2 equivalent emissions are avoided by an urban resident who travels 5 kms by cycling rather than by car during rush hour periods. The report from Centers for Disease Control and Prevention point out that cycling also help preventing disease like obesity, heart

disease (can reduce up to 82%) and diabetes (can reduce up to 58%). Therefore, bicycle-sharing system has a positive impact on mental and physical health, which attract more people to use. This is very helpful for both working professionals as well as students also.

## 8. CONCLUSION

Bicycle sharing has been the greatest growth of any transport initiative in recent years, When you look at the future, there are obvious innovations that are certain to take place. How and when those will happen, however, is more difficult to predict the future. Optimizing the fare structure will expand user access to a wider range of users, as well as increase the overall cost recovery by use. It will also serve to make the fare structure more transparent to users, lowering complaints and increasing customer satisfaction, which is important to potential sponsors, to the City and to the operator." This is not a bad idea but might be hard to implement in cities where the free period is entrenched in the concept of bicycle sharing. Cohen further states that, however the new bundling of trip fares is done, there still must be the usage fee after a certain period of time to motivate users to return the bicycles. The use of collection of data and analysis to monitor and optimize bicycle sharing systems has only scratched only the surface. As with all transport, bicycle sharing will continue to embrace technology that will make system design, innovative revenue streams and integration easier and cheaper. E-bikes and scooters will definitely find their way into bicycle sharing systems or use bicycle sharing models to create their own system. Work is currently being undertaken in developing the hardware and associated operational support to handle charging both at the station and at a central location. An area of potential huge growth is whether e-bike sharing can replace private scooter trips in Asian cities, where scooter use can be up to 75 percent. If it could, the environmental and social benefits could be enormous, as governments could then control emissions, speeds and parking issues of significant importance.

## 9. REFERENCES

[1] Bike-Sharing Programs Hit the Streets in Over 500 Cities Worldwide; Earth Policy Institute; Larsen, Janet; 25 April 2013

[2] "In Focus: The Last Mile and Transit Ridership". Institute for Local Government. January 2011.

[3] James May (21 October 2010). "May, James, "Cycling Proficiency With James May", The Daily Telegraph, 21 October 2010". London: Telegraph.co.uk. Retrieved 2012-01-15.

[4] Free City Bike Schemes, Søren B. Jensen, City of Copenhagen, Conference Proceedings, Amsterdam 2000

[5] "Bike sharing: Research on health effects, helmet use and equitable access". Journalist's Resource. 2018-04-05. Retrieved 2018-09-06.

[6] "Mobiped". Mobiped. 11 October 2010. Archived from the original on 22 September 2011. Retrieved 2012-01-15.

[7] Bieler, Andrew (December 2008). "Bikes as a Public Good: What is the Future of Public Bike Sharing in Toronto" (PDF). Retrieved 1 March 2018.

[8] "The Sharing Economy is Learning How to Ride a Bike". Energy Institute Blog. 2018-02-20. Retrieved 2018-03-07.

[9] Taylor, Alan (22 March 2018). "The Bike-Share Oversupply in China: Huge Piles of Abandoned and Broken Bicycles". The Atlantic. Retrieved 16 April 2018.

[10] "The Bike-sharing World Map is 10 years old". Bike-Sharing.blogspot.com. Retrieved 25 May 2018.

[11] "Bike Sharing Program Rolls on Campus during Summer". Georgia Tech News Room. 20 June 2011. Retrieved 2 January 2012