

# Wireless Network Sensor Monitoring Platform Using Pipeline Inspection Robot

DS.Vigneshwaran<sup>1</sup>, R.Rasheed Abdur Rahman<sup>2</sup>, R.Vignesh<sup>3</sup>, J.Mary suji mol<sup>4</sup>

<sup>1,2,3,4</sup> Department of Electronics and Communication Engineering,  
JEPPIAAR SRR Engineering College, Old Mamallapuram road, I.T. Highway, Padur, Chennai -603103.

\*\*\*

**Abstract** - Pipeline-based applications have become an integral part of life. However, knowing that the pipeline systems can be largely installed in an obscure and uncertain environment, active monitoring and frequent inspection of the pipeline systems are highly expensive using the traditional maintenance systems. Robot agents have been considered as an attractive alternative. Although many different types of pipeline inspection robots have been proposed, they were suffered from various disadvantages. Corrosion accelerates progressively and long term failure increases the probability of cracking. Limiting regular monitoring activities to the "scrap" part of the pipelines only, results ultimately into a pipeline system with questionable integrity. The confidence level in probity will drop below acceptance levels. Inspection of presently uninspected sections of the pipeline system becomes a must. This project provides information on the "robotic inspection technology" using wireless network sensors.

**Key Words:** uninspected sections, active monitoring and frequent inspection, pipeline exploration robots, fatigue cracking.

## 1. INTRODUCTION

Pipelines are proven to be the safest way to distribute Gases and Liquids. Regular monitoring is required to maintain that state. The larger part of the pipelines system is accessible by In-Line Inspection Tools but this access is limited to the section in between the initial and receiving traps only. Unfortunately, corrosion does not have this disadvantage. The industry looks for means of inspecting these in-accessible pressure holding pipe systems, preferably, without interrupting the operations. It is a fact that sufficiently protective and correct inspection results can only be obtained by direct pipe wall contact/access. If that is not sensible from the outside, we have to go inside. Since modifying pipeline systems for In-Line Inspection is mainly not practical, PIPE INSPECTION ROBOT follow development of ROBOTIC inspection services for presently in-accessible pipeline systems. However, a large number of structural deficit have surface indicators (e.g. corrosion, concrete deterioration). Aside from short range of detection, visual inspection does have further drawbacks. It is extremely personal as it depends on inspector's training, visual sharpness, and state-of-mind. Also external elements such as light intensity, structure complexity, and structure accessibility play a role in determining the effectiveness of visual inspection.

## 2. BLOCK DETECTION

Number of robot systems for pipeline monitoring has been developed in history of pipeline inspection. They are designed to detect and locate leakage, damage and corrosion in pipeline systems.

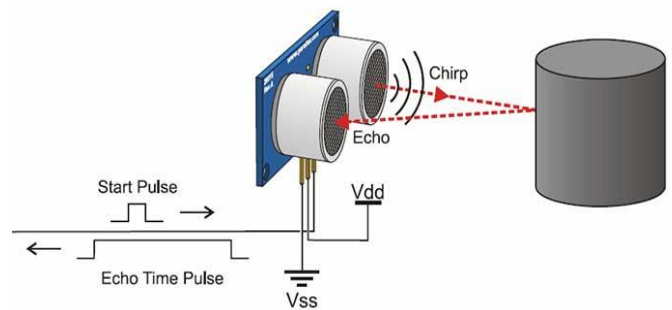

Fig -1: Ultrasonic wave propagation

Ultrasonic Sensor used to sense the object which found in the route. Ultrasonic sensors work on a principle which is similar to sonar in which distance of a target by explicit the echo from ultrasonic sound waves. This ultrasonic module measures the distance precisely within 0cm - 400cm with a gross error of 3cm. Sensor send an sound wave at particular frequency and produces an output pulse that corresponds to the time required for the burst echo to return to the sensor. By measuring echo pulse width, the distance to object can be calculated easily.



Fig -2: HC-SR04 Ultrasonic Sensor

Here we use HC-SR04 Ultrasonic sensor is used for remote measurement of some physical quantities via ultrasonic waves. These waves are generally inaudible to human ear. This device has an ability to detect a distance 400 cm approximately.

The working principle of the ultrasonic sensor is the same as that of bat's object detection ability. An ultrasonic transmitter sends a RF wave of 40 KHz in the air at the speed of 346 meter per second and the ultrasonic receiver receives the signal reflected from the object. By recording the elapsed time between the sound wave being generated and the sound wave bouncing back, it is possible to calculate the distance between the SONAR sensor and the object. Therefore the analogue signal received is converted to digital signals. As the speed of the ultrasonic wave in the air medium is constant and known, it is simple to find the distance.

### 3. CRACK DETECTION

In the robot module Infrared sensor used to detect the cracks in the pipeline. The IR sensor which transmits light which it absorbs means the crack will be detected. If light will be reflected means there is no crack formed.

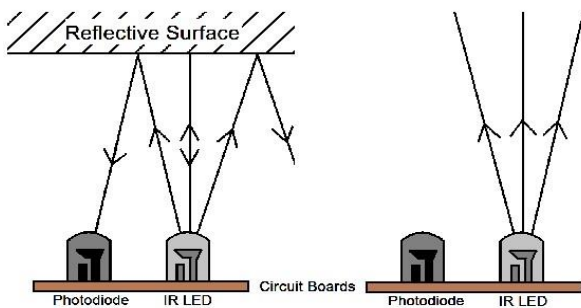

Fig -3: Working Principle of IR sensor

Infrared sensors comprises of both IR photo diode and IR LED together they are called as Photo-Coupler. It is the form of diodes with 2 terminals. There are two diodes transmitter diode and receiver diode. On careful observation, you will notice that amongst the two 'legs', one has a much wider base within the diode. It is normally the cathode (negative terminal) whereas the leg having a smaller base would be the anode (positive terminal).

When Transmitter is forward bias, it begins emitting infrared rays. Since it is not in visible spectrum, one will can't able to see it through naked eyes but one can able to view it through an ordinary cell phone camera.

An infrared sensor is an electronic device, emits in order to sense some aspects of the surroundings. An Infrared sensor can measure the heat of an object as well as sense the motion. These types of sensors evaluate only infrared radiation, rather than emitting it, this is known as a passive IR sensor. Usually in Infrared spectrum, all the objects radiate some form of thermal radiations. These types of radiations are invisible to our eyes, which can be sensed by an infrared sensor. The emitter is an Infrared LED and the detector is an Infrared photodiode which is sensitive to Infrared light of same wavelength as that is emitted by the Infrared LED. Infrared light falls on the photodiode, the resistance and

output voltages change in proportion to the magnitude of the Infrared light received.

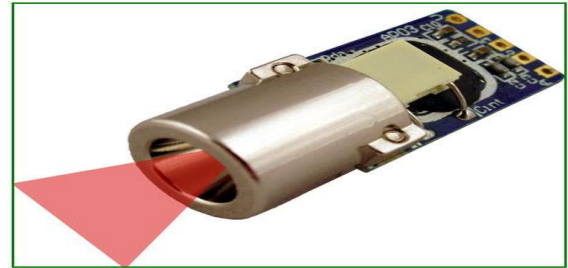

Fig -3: IR sensor circuit diagram

This circuit consists of the following components LM358 IC 2 IR transmitter and receiver pair, Resistors of the range of kilo ohms, Variable resistors, LED. The transmitter section includes an IR sensor, which transmits continuous infrared rays which is received by an IR receiver module. An infrared output terminal of the receiver varies depending on its receiving of infrared rays.

### 4. PIPELINE ROBOT VEHICLE

Pipeline robot vehicle consists of Ultrasonic sensor, Infrared sensor, zigbee module, UART, Arduino, relays, DC motor, battery and buzzer.

ZigBee is a mesh network specification for low-power wireless local area networks (WLANs) that cover a large area. The distances that can be achieved transmitting from one station to the next extend up to about 70 meters. ZigBee is often associated with machine to machine communication and the Internet of Things.

The Arduino Uno is a microcontroller board based on the ATmega328. It has 14 digital input and output pins, 6 analog input pins, a 16 MHz crystal oscillator, a USB connection, a power jack, an ICSP header, and a reset button.

UART is a hardware device for asynchronous serial communication in which the data format and transmission speed is customisable. It is an IC used for serial communication.

A DC motor is any of a class of electrical machines that converts direct current electrical power into mechanical power. Relays are simple switches works in both electrical and mechanical environment. Relay consists of an electromagnet and also a set of contacts. It consists of a control circuit and a load circuit. These are also called as motor drivers used to drive the DC motor.

A battery is a device has electrochemical cells that convert stored chemical energy into electrical energy. There are two types of battery, primary (disposable) and secondary (rechargeable) battery.

Warning systems like buzzers could be very beneficial in minimizing loss of lives during a disaster or accident. They are important devices in any building or facilities to alert and notify people if a timely evacuation is necessary. Specialized electric alarm systems are called buzzers.

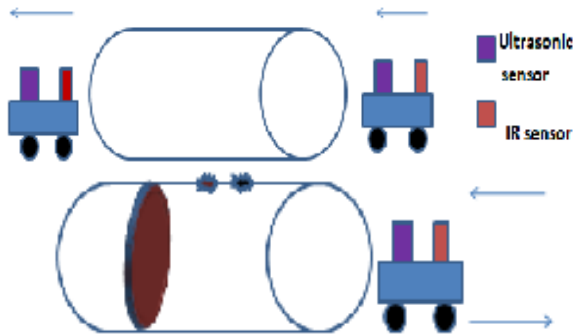

Fig -4: Pipeline robot model

Robot is fed into one side of pipeline. Ultrasonic sensor emits sound waves at particular frequency to detect blocks and IR sensor consists of photo diode that emits light rays to detect cracks. If there is no block or crack, robot moves further and comes out at other side. If there is any block or crack robot detects it and virtually it sends information to PC using UART via Zigbee module. Thus the robot stops and moves in reverse direction.

## 5. DATA PROCESSING

The data processing is the task of checking the various sensors data received from the sensors with the already fixed threshold values. The connection is established between Arduino, Ultrasonic sensor, then from relay to motor. The threshold value will be programmed in the Arduino. To regulate the speed, the distance value is checked with the threshold value. If the distance between the SONAR and the object goes beyond the threshold value, then the motor speed will be reduced and will be stopped slowly. Here the object refers to the pipeline robot vehicle.

### 5.1 Arduino and Ultrasonic sensor

In the ultrasonic sensor, these four pins are to be considered: (VCC+5v): The +5V pin is needed for connection in the Ultrasonic Sensor HC-SR04 Pin, (Trigger): Triggering has to be done for sending the sensor signals, (Echo): The sensor signals are transmitted and received by bouncing back. While receiving the sound wave the echo pin goes high, (GND): Ground connections are given. These pins help to detect the objects in front of it or to measure the distance between the objects. The sensor is triggered by using a signal of +5v over the trigger pin for 10 seconds. Once the trigger signal is received, the ultrasonic sensor transmits the ultrasonic waves. If there is some object in front, the waves will be reflected back. The ultrasonic receiver then captures the signal reflected, thereby making the echo pin high. The

time for which the echo pin goes high is read. On the basis of this time calculated, we can find the actual distance of the object i.e. how far it is from the car. The Arduino and ultrasonic sensor can be interfaced. The code where the SonarSensor() function is used to generate pulse of 10 microsecond and sending it to the trigger pin of Ultrasonic sensor. The PulseIn() function is used to say how long the echo pin is high. By using this time we can calculate the distance.

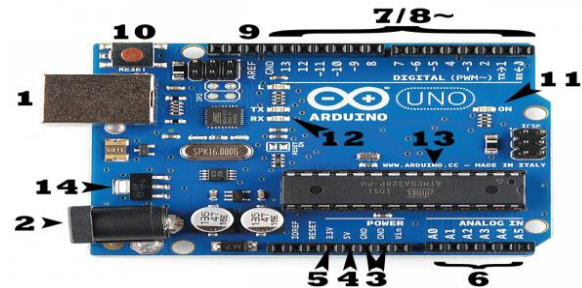

Fig -5: Arduino UNO board

The distance is divided by 2 because the sound waves travels to and fro. The value is again divided by 29.1 which is the speed of the sound. At the last the distance value is obtained in cm. The distance will be displayed in the LCD. The LCD will be connected to the Arduino by collecting the following pins. LCD RS pin with digital pin 12, LCD enable with digital pin 11, LCD D4 pin with digital pin 5, LCD D5 pin with digital pin 4, LCD D6 pin with digital pin 3, LCD D7 pin with digital pin 2.

### 5.2 Software Requirements

Here we use Arduino software (IDE). The Arduino Integrated Development Environment consists of a text editor for writing code, a message area, a text box, a toolbar with buttons for common functions and a series of tools. It links the Arduino and Genuino hardware to upload programs and communicate with the system. Programs coded using Arduino Software are known as sketches. These sketches are written in text editor and are saved with the file extension named .ino. The editor has features for cutting, pasting and for searching and replacing text. The message area gives feedback while saving and transport and also displays errors. The console box displays text output by Arduino Software, including complete error messages and other details. The bottom right hand corner of the window displays the configured board and serial port. The toolbar buttons allows us to verify and upload programs, create, open, and save sketches.



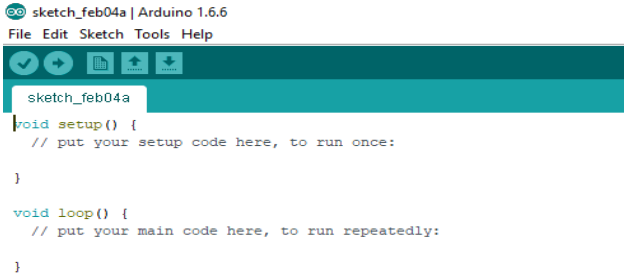

Fig -6: Arduino IDE workbench

### 5.3 Controlling the speed

There is no change of speed in robot motion unless or until it senses a block or crack, it moves in a forward direction with constant speed. If a block or crack is detected means with the help of the motor driver the rotation of DC motor changes and the robot stops and move towards reverse direction. The speed of the vehicle has to be controlled by 3pwm, varying the potentiometer which is also connected to the Arduino. The circuit connection includes Arduino, transistor, DC motor, diode and 10K ohm resistors. Potentiometer regulates the speed such as, turning in one direction reduces the speed and other increases the speed of the vehicle. The threshold value will be programmed inside the Arduino. According to the threshold value the distance value will be controlled by the potentiometer. Therefore the vehicle speed will get reduced automatically. The 5v relay, 4N25 optocoupler are used since the relay regulates the voltage level.

### 6. DATA TRANSMISSION

The data acquired from the sensors are transmitted to the Web server by using UART. UART is a form of serial communication because the data is processed and transmitted as sequential bits.

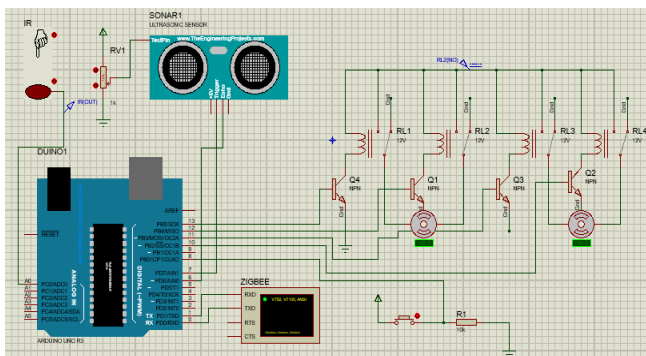

Fig -1: Embedded design kit using proteus

UART consists of two lines. One for transmitting the data (Tx) and the other line for receiving the data (Rx). Both the lines together form a serial port through which the communication can occur. It is an onboard hardware. It

manages the serial data packaging and translation. It is interfaced with the Arduino, which has a serial port dedicated for the communication with the computer on which the Arduino is connected to. UART is asynchronous because the communication does not depend on a synchronized clock signal.

### 7. CONCLUSION

This idea of detecting blocks and cracks in underground pipeline system can be implemented with simple process. This concept will serve well for municipal corporation board in order to detect and correct underground pipelines. The pipeline inspection robot can also used in surface oil pipelines and gas pipelines to detect blocks and cracks. This is a combinational system and the output will be for the betterment of the pipeline systems. Pipeline robot is capable of performing short and long-range inspections under various operating condition, which is applicable in water, wastewater, industrial and power applications. Robot’s track feet can be changed out depending on the pipe type and expanded for larger diameter pipes. The pipe inspection robot inspects situation inside the pipe which is recorded and displayed on the monitor screen, it also facilitates working personnel for effective observation, detection, quick analysis and diagnosis. Save comprehensive investment, improve work efficiency and more accurate detection. Operating cost and cost of manufacturing of this robot is relatively low.

### 8. REFERENCES

- [1] H. M. Kim, S. U. Yang, Y. S. Choi, H. M. Mun, C. M. Park, and H. R. Choi, "Design of back-drivable joint mechanism for in-pipe robot" .
- [2] Y. S. Choi, H. M. Kim, J. S. Suh, H. M. Mun, S. U. Yang, C. M. Park and H. R. Choi, "Recognition of Inside Pipeline Geometry by Using Monocular Camera and PSD Sensors"
- [3] H. Saeed, S. Ali, S. Rashid, S. Qaisar, and E. Felemban, "Reliable monitoring of oil and gas pipelines using wireless sensor network (WSN)".
- [4] Salman Ali, Adnan Ashraf, Saad Bin Qaisar "A Wireless Sensor Network Monitoring Platform for Oil and Gas Pipelines".
- [5] Ho Moon Kim, Yun Seok Choi, Yoon Geon Lee "Novel Mechanism for In-pipe Robot Based on Multi-axial Differential Gear Mechanism".