

E-TOLL TICKETING FOR MULTI VEHICLE TRANSPORTATION SYSTEM

K.Krithekaa¹, J.Indumathi², S.Kalaivani³, Sunitha Biji.T⁴

^{1,2,3} Student, Jeppiaar SRR Engineering College, Tamil Nadu, India

⁴ Assitant Professor, Jeppiaar SRR Engineering College, Tamil Nadu, India

Abstract: An e-toll ticketing system for multi vehicle transportation system which is entirely based on smart card using Radio Frequency Identification which is the emerging technology that could reduce man power, increase efficiency and fastens the process of toll plazas collection. Each vehicle is been fixed with RFID reader thus the indication is given after the vehicle crosses the toll. After the vehicle has crossed the toll the reader reads the data from the centralized database and the amount deduction (i.e.,) the amount transaction is intimated to the user's mobile using GSM technology. The target of our project is to bring in system that automatically allows the vehicle to cross the toll and record the date and time .If the RFID card is valid (i.e.,) if the card contains the requited amount the toll gate automatically opens and thus the required amount is deducted according to the user input value .Therefore this system helps us in reducing traffic congestion in toll gates and helps in consuming less fuel and time.

Keywords: RFID technology, Flex sensor, IOT, E-toll, GSM module, Theft control.

Introduction:

The automatic toll e-ticketing is mainly used for the vehicle that reaches the toll gate. The vehicle containing RFID tags approaches the toll is detected by using an infrared sensor. The RFID tags contain a 16-bit unique number. This unique number gives the information about the vehicle and the owner. This RFID system evolved with various interconnected networks like satellite navigation which gives the common database which makes the transportation in a unique way.

The RFID technology on the toll gate has a tag which has details about vehicle owner and the details of the vehicle. In the toll gate, transaction (i.e.,) an deduction is in multi-lane free flow system and thus Non-stop vehicle transaction are done using passive RFID tag.

The flex sensor is used is to find whether the vehicle has to pass the toll gate for only one time or to pass the same toll gate again for returning .in simple it is denoted as "one way" or "two way". Flex sensor or also popularly, known as bend sensor is used to measure the amount of bending or deflection. This sensor is mainly in human machine interface devices. Generally, the flex sensor is attached to the surface, where by bending the surface the resistance of the sensor element is varied.

An android application is created by using the software development kit (SDK). This IOT based Application is used by the amount balance. This Application is created as open source so it can be easily extended.

Existing system:

The existing system incurs two methods they are collection of amount manually and another system is the smart card system

The manual method usually includes a wait in toll gate such that when the vehicle approaches the toll. The person driving the vehicle will have to pay his/her amount respectively to the person in the toll based on the single or double way transportation. After the payment is done he/she has to wait for receipt and then only can cross the toll. This way of manual toll gate has few major disadvantages like long time waiting at the toll gate, involvement of man power, traffic congestion. This method can cause even more serious issues such as theft of vehicle, entry of unauthorized person and illegal activity through roadways

The another method is the smart card method in this method the person having a smart card show the card in toll booth and amount in the card is deduced. The smart card holder can make an annual payment to make use of the card whenever needed throughout the year. Though this method has a better advantage over the manual way of toll collection it also contains one disadvantage the concession for double way transportation cannot be got in this type of method.

Proposed system:

The proposed method helps in giving a highly safe, secured and fast toll gate environment. In this environment all the toll action are done automatically in a fast manner.

The IR sensor is used to detect the incoming or the outing vehicles at the gate modules. After the detection it indicates the controller about the entry of the vehicle such that the gate model open and closes. The tag of the vehicle is read by the RFID reader which placed in the toll plaza. The vehicle details have been already stored in the toll plaza based on tag number when the user was issued with the unique RFID tag.

The flex sensor which is called bend sensor plays a vital role in this setup the user is being provide with flex sensor he or she has to bend the finger to indicate whether it is a single

way or a double way transportation. The single bend indicates that it is single way transportation and the double bend indicates that it is double way transportation. Based on the values of the user the amount required to cross the toll is deduced from the users RFID TAG. The amount reduction is intimated through message to the user mobile through GSM technology.

This system is also has one advantage is that it is been developed with application based on IOT. This application can be installed in the vehicle owners mobile. It has a unique user id and a password such the particular person having the id can only login check his/her toll details. The toll details include time, place of the toll, balance in the card.

The main objective of the proposed system is to provide a highly secured, safe and fast toll gate environment. However the proposed system requires a major change in infrastructure of the existing toll gates.

Block diagram

The components that used in this e-toll ticketing system are shown in the diagram.

The RFID reader and the RFID tags are main components of RFID technology .RFID reader transmits the radio frequency signals which is received by the antenna in the tag which in turn gives back the feedback signal to the reader. The detailed description of each and every components used in the system along with their features are given as the following.

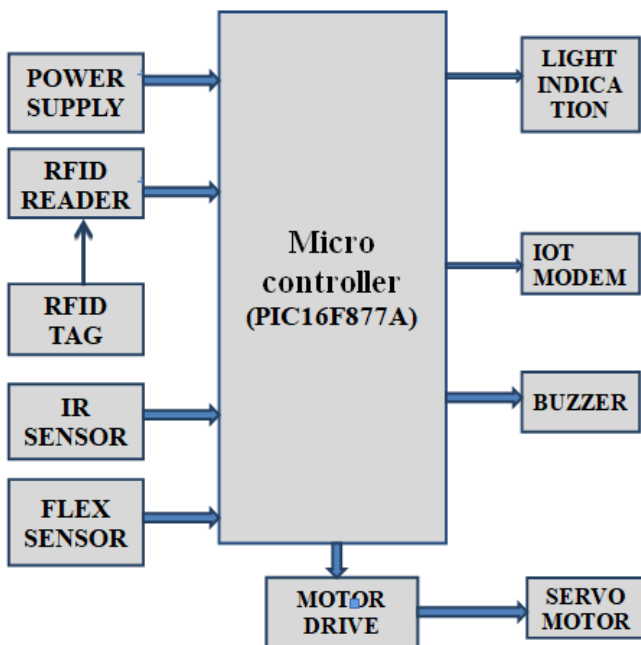

1. POWER SUPPLY:

The regulated power supply provides the required input voltage to the circuit. The main supply gives ac input (i.e.,)

230V is step down by the transformer to 12V and is given to the rectifier. The output from the rectifier is pulsating dc voltage. In order to covert this pulsating voltage in to pure dc voltage, the output of the rectifier is given to the filter that removes the ac components which even presents after the rectification. The output from the filter is given to the voltage regulator, which gives the constant pure dc voltage to the circuit.

2. RF Reader & RF Tags:

The abbreviated form of RFID is Radio Frequency Identification.

An RFID system requires a RFID reader and a RFID tag:

- **A reader**, including an antenna -Device that is used to read and/or write data to RFID tags.
- **A tag**-Transponder that carries data transmits to a reader. Tag with the data in it can identify an item in manufacture, goods in transit, location, vehicle, an animal or individual.
- **The communication**-RFID uses a defined radio frequency to transmit and receive data from tags. The data travels through radio waves.

An RFID reader is a device that is used to interrogate an RFID tag. The reader has an inbuilt antenna that emits radio waves; the tag responds by sends back its data.

Features:

- It requires 5Volt dc supply
- It can read up to 125 khz.
- 9600bps TTL and RS232 output
- 100mm read range

3.IR SENSOR:

IR sensors are in the form of diodes with 2 terminals. A pair of such diode (one transmitter and one receiver) is available at a very low cost . Its operation can be viewed as 2 cases as follows:

Case 1: when no IR is incident upon the Rx:

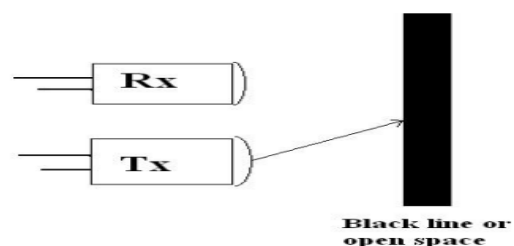

Case 2: when IR is incident upon the Rx:

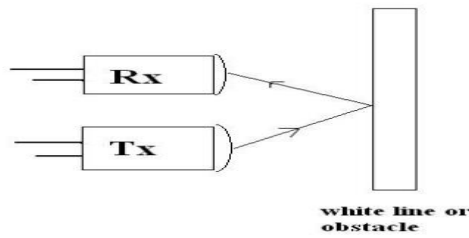

4. FLEX SENSOR

Flex sensor or also popularly, know as bend sensor is used to measure the amount of bending or deflection.

Generally, the flex sensor is attached to the surface, where by bending the surface the resistance of the sensor element is varied. Since the resistance is directly proportional to the amount of bend it is used as goniometer, and often called flexible potentiometer.

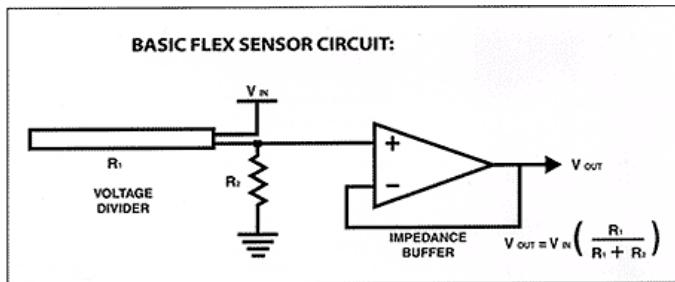

5. IOT MODEM:

Here we are using the GSM modem for the message passing through the mobile phone, which is already registered. Global System for Mobile (GSM) is a second generation cellular standard developed to cater voice services and data delivery using digital modulation. The diagram circuit that used to interface is shown as:

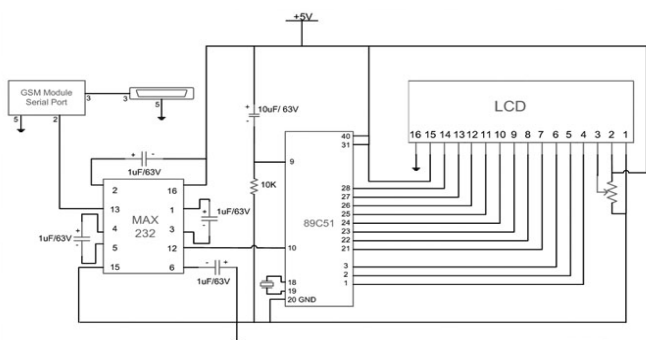

6. DC Motor with drive

A motor driver is a little current amplifier; the function of motor drivers is to take a low-current control signal and then turn it into a higher-current signal that can drive a motor.

DC motor is an electric motor that runs on direct current (DC) electricity.

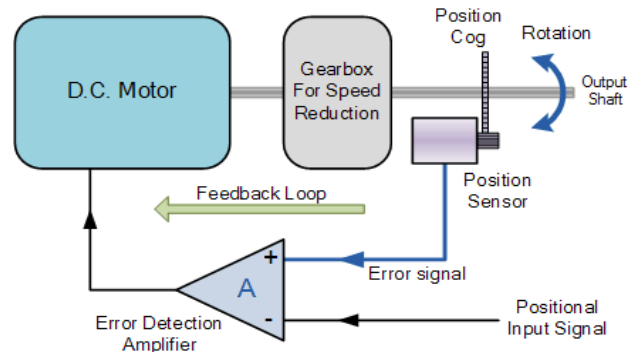

7. Microcontroller

PIC CONTROLLER:

The controller we using in this system is PIC16F874A. Micro controller senses the signal given from switches and decides the mode of operation i.e. recharge mode or toll collection mode. It fetches data from memory location and send it to output devices like display, motor driver and buzzer. At the same time it can accept data from Keypad for recharging options and from IR receiver to sense that vehicle has passed from toll collection booth.

The main features of this controller are:

- Programmable code protection
- Power saving Sleep mode
- Selectable oscillator options
- In-Circuit Debug (ICD) via two pins
- Low-power, high-speed Flash/EEPROM technology
- Fully static design
- Wide operating voltage range (2.0V to 5.5V)

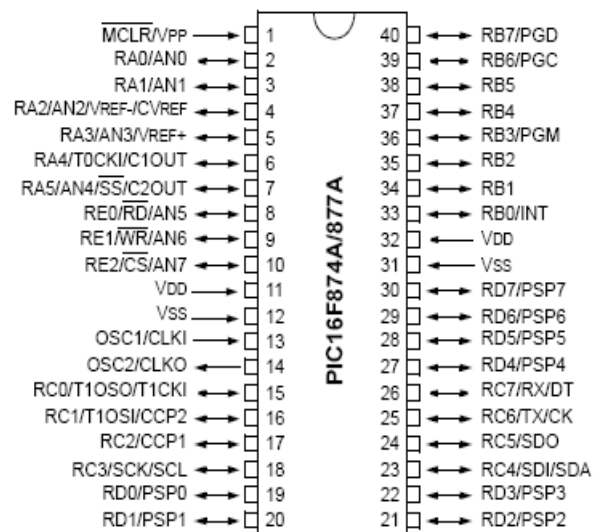

8. LCD display:

It is combination of two states of matter, the solid and the liquid. LCD uses a liquid crystal to produce a visible image. Liquid crystal displays are super-thin technology display screen that are generally used in laptop computer screen, TVs, cell phones and portable video games.

The principle behind the LCD's is that when an electrical current is applied to the liquid crystal molecule, the molecule tends to untwist. This causes the angle of light which is passing through the molecule of the polarized glass and also cause a change in the angle of the top polarizing filter. As a result a little light is allowed to pass the polarized glass through a particular area of the LCD.

9. Buzzer:

Buzzer is an electronic device commonly used to produce sound. Piezo buzzer is based on the inverse principle of piezo electricity. It is the phenomena of generating electricity when mechanical pressure is applied to certain materials and the vice versa is also true.

CIRCUIT DIAGRAM:

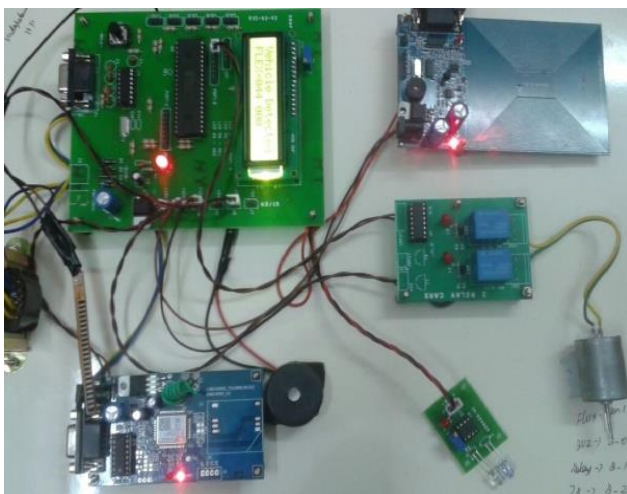

OUTPUT:

1. When vehicle is detected:

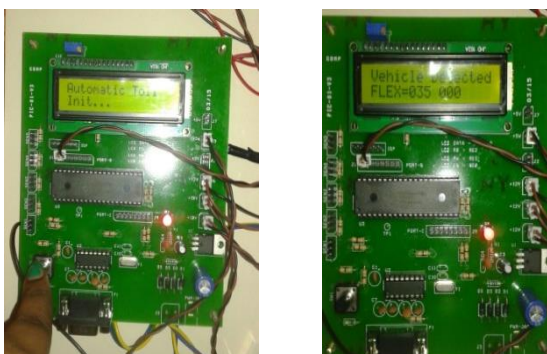

2. When the user represents one bend:

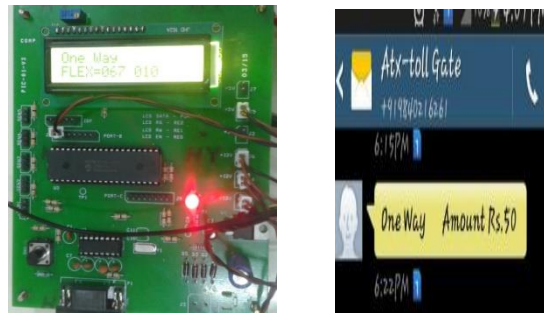

3. when the user represents two bends:



IOT APPLICATION OUTPUT:

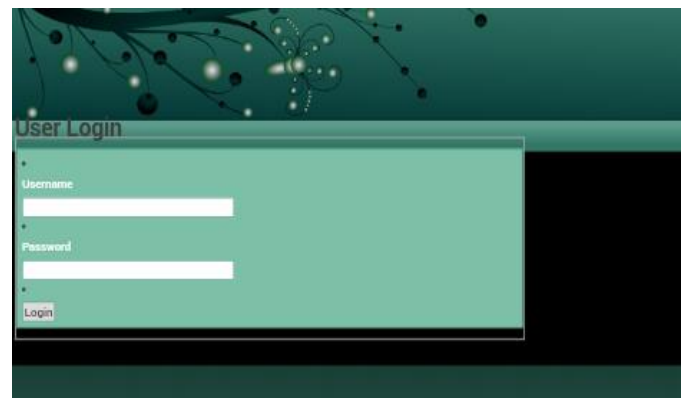

1. APPLICATION LOGIN PAGE

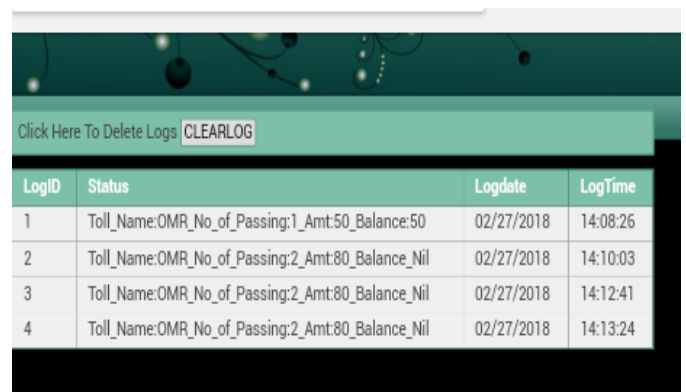

2. DETAILS OF VEHICLE PASSING

4. CONCLUSION

Thus proposed method can be able to contribute an improvement in the traveling conditions by addressing the delay caused by congestion at the toll. The automatic e-toll ticketing system is helps to attain a safe and traffic free environment for the toll collection and to control the movement of the vehicles at the toll booth. In this system IR sensor is used for the detection of the vehicle it makes the Gate models to open and close while the vehicle passing the toll station. The tags that are attached on the vehicles are read by using the RFID reader. Based on the TAG numbers, information's are stored in the microcontroller. This system can easily collect the specific amount from the people without making them stay at the toll booths. This achieved by using the wireless technique of data transfer from vehicle to the micro controller and vice versa. And that amount detection is send as SMS using the GSM model to the registered mobile phone of the owner. An IOT Application is used to find the number of times a vehicle passes through the toll booth .And it also gives the information about how many vehicles has passed through a particular toll per day. Thus it adds advantage to both the authority of the toll booth and the user in terms of cost and time. It also includes the advantage of increased security, increased capacity and greater convenience. However, this proposed system requires major changes in the infrastructure of the existing toll roads.

5. REFERENCES

1. Continuous monitoring of human health using Internet of Things "International Journal of Advanced Research Methodology in Engineering & Technology", Special issue, March 2017, ISBN 978-1-63535-324-2, page No:61-64.
2. Sana Said Al-Ghawi Muna Abdullah Al Rahbi , Dr. S.Asif Hussain, S.Zahid Hussain," Automatic Toll E-ticketing System For Transportation Systems" International conference on Big Data & Smart City, December 2016
3. Kamichetty Pramodh Kumar, Kasturi Sai Ratna Gayatri, Reddy Akshay "Automated Toll Collection System using RFID" IJRASET , October 2014.
- 4.2016 3rd MEC International Conference on Big Data and Smart City.
5. Tejonidhi Aphale, Rahul Chaudhari, Jinit Bansod, "Automated Toll Plaza using RFID & GSM" IJRITCC, September 2014.
6. Sachin Bhosale, Dnyanshwar Natha Wavhal, "Automated Toll Plaza System Using RFID," IJSETR, Volume 2, Issue 1, January 14.
7. AnugMyintbWin, Chaw MyatNwe, Kyaw ZinLatt, "RFID Based Automated Toll Plaza System," IJSRP, Volume 4, Issue 6, June 13.

8. Scalable RFID Systems: A Privacy-Preserving Protocol With Constant-Time Identification" by Basel Alomair, Andrew Clark, Jorge Cuellar, and Radha Poovendran (2012)

9. Implementation Of Rfid And Bluetooth Technology For Data Tagging And Transmission To Point Of Sale" by M. B. Roslee and T. W. Lee (2012)

10. <https://www.rroij.com/.../automatic-toll-gate-system-using-advanced-rfid-and-gsm-tech>.

11. W.-H. Lee, B.-S. Jeng, S.-S. Tseng, and C.-H. Wang, "Electronic toll collection based on vehicle-positioning system techniques, in Proc. IEEE Int. Conf. Networking, Sensing, and Control, Taipei, Taiwan, R.O.C., Mar. 21-23, 2004, pp. 643-648.