

VEHICLE SAFETY WITH DIALLING SYSTEM AND AUTOMATED LOCATION TRACKER

K.N. Mohammed Mansoor¹, A.Shrikaanth², A.Karthick³, P.Sivasakthy⁴

^{1,2,3} Student, Electrical and Electronics Engineering, JEPPIAAR SRR Engineering College, Chennai, TN.

⁴Assistant professor, Electrical and Electronics Engineering, JEPPIAAR SRR Engineering College, Chennai, TN.

Abstract – This project presents the hardware design and implementation of the system that ensures the safety of the vehicle and user. This system uses the PIC16F877a microcontroller and various sensors like MEMS sensor, Gas leakage sensor, Airbag sensor and GSM module. The microcontroller is connected to the car battery which acts as the power source. The Gas leakage sensor is placed near the gas cylinder and MEMS sensor can be placed anywhere in the car. The MEMS sensor senses the vibration of the car from outside and Gas sensor senses the leakage of gas from inside. The GSM module uses the active networks to send the information and gain attention from emergency center. The sensor information can be monitored by the driver via Microcontroller LCD.

Key Words: PIC16F77, MEM sensor, Airbag sensor, GSM module, Gas sensor.

1.INTRODUCTION

Fatigue, lack of light, compromised night vision, rush hour and impaired drivers all contribute to making driving at night more dangerous than during any other time of day. In fact, the risk of a fatal crash is three times greater at night, according to National Safety Council research. Most cases victim dies even before reaching hospital if the accident occurs in a remote area where chances of getting help or access to hospital are very less. In our proposed system, we use Gas leakage sensor that senses the leakage of gas and intimates the user through LCD. The MEMS sensor senses the vibration so that we may determine the level of damage to the vehicle. All these information are sent to the active networks like Cyber crime networks to get medical attention. Thus, medical attention and safety of vehicle is achieved irrespective of time and place.

2. EXISTING SYSTEM

Currently there is some complex systems are available to intimate accidents occurring in highways to nearby hospitals. Due this there are possibilities of threats like loss of life due to a small reason like no hospitals inside the radius. In existing, we are sending the alert intimation as a text message. In case, If the message will not delivered successfully or it will take too long to delivered then there is no use

2.1 DRAWBACKS IN EXISTING SYSTEMS

There is only a text message SMS will be send to the care takers or a mobile users. There is no use, if the message is not seen by the user. Using GPS and GSM modem make the system more complex and costly. If the SMS is not send/delivered successfully then the system will be a fail.

3.PROPOSED SYSTEM

We are proposing a new technique to intimate the accidents to the control room of medical center or care takers, as early as possible and with location also. We can easily find the level of accident. The receiver can get the updated information to the phone. This will be a much simpler and low cost technique compared to others, thus saving lots of human life.

3.1 BLOCK DIGRAM

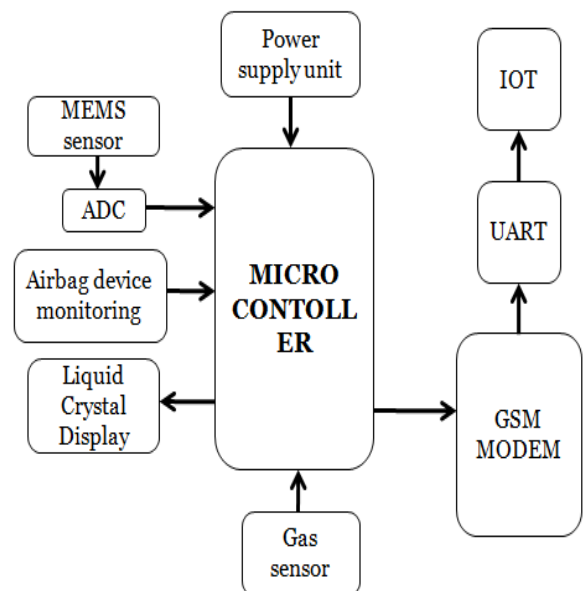

FIG 1:Block diagram of proposed system

3.2 CIRCUIT DIAGRAM

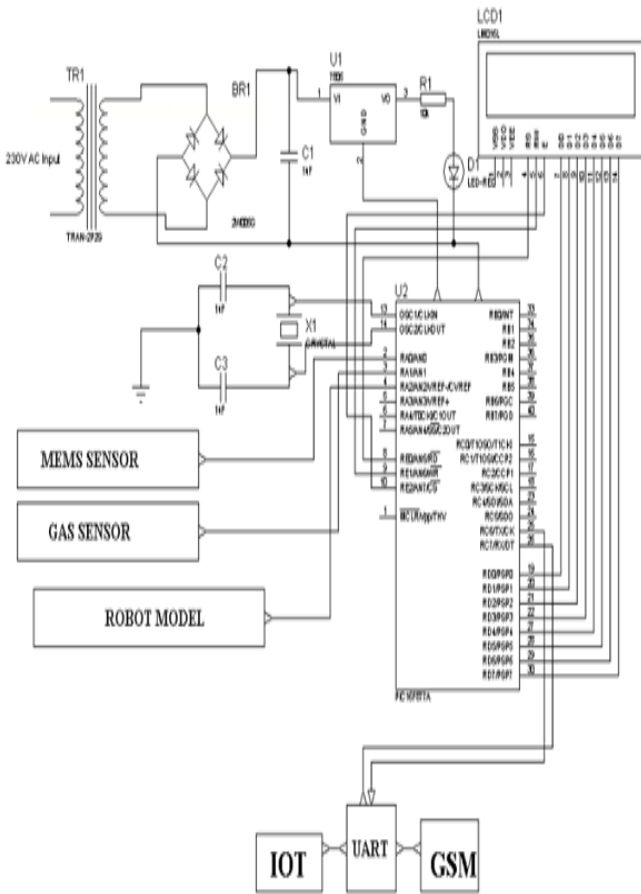

FIG :2 Circuit diagram of proposed system.

3.3 EXPLANATION:-

Initially, MEMS sensor senses the vibration developed in car. If the vibration exceeds the set value, sensor sends signal to the microcontroller. In the event of gas leakage a signal is passed on to the microcontroller by the sensor placed near the gas cylinder. Along with that GPS is used for finding location of particular vehicle. Airbag monitoring device continuously monitors the working of airbag. All the above signals are given as **input** to the microcontroller. The microcontroller used here is PIC16F877a. The microcontroller sends signal to GSM modem which sends message and intonation to emergency centre. All these information are updated in IOT.

3.4 ADVANTAGES

Here the GSM is used for getting the location, and start the voice call alert, and also sending the SMS. Voice call alert make this system more efficient and reliable. Getting the location without using GPS modem makes this system compact and low of cost.

4. SIMULATION

4.1 SIMULATION RESULTS

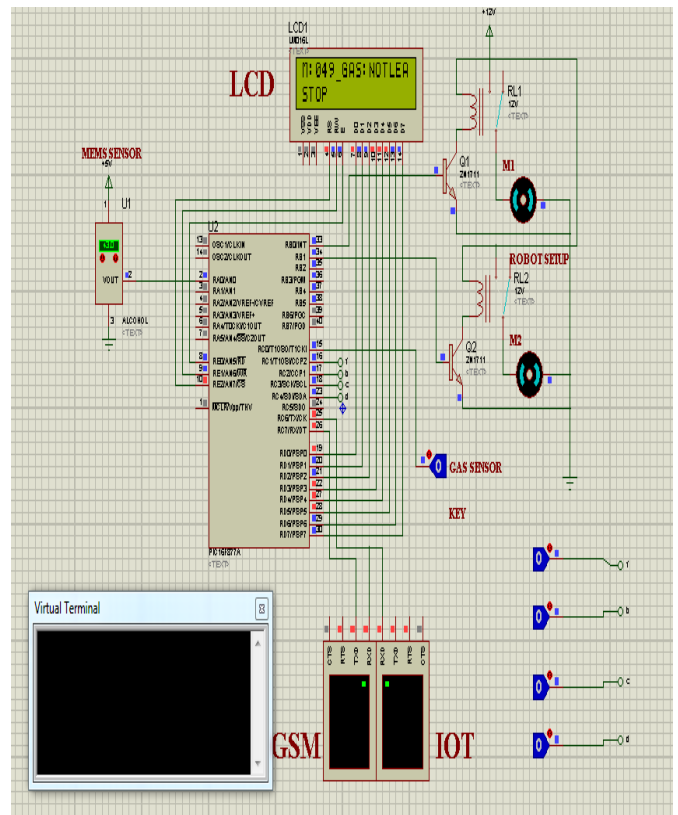

FIG: 3 location tracker

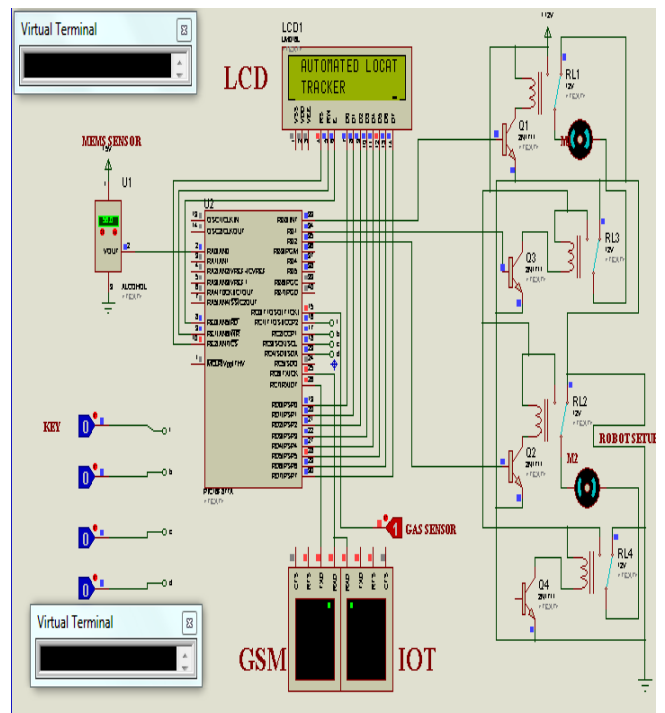

FIG: 4 simulation output under normal condition

5. HARDWARE:

5.1 PIC16f877a:-

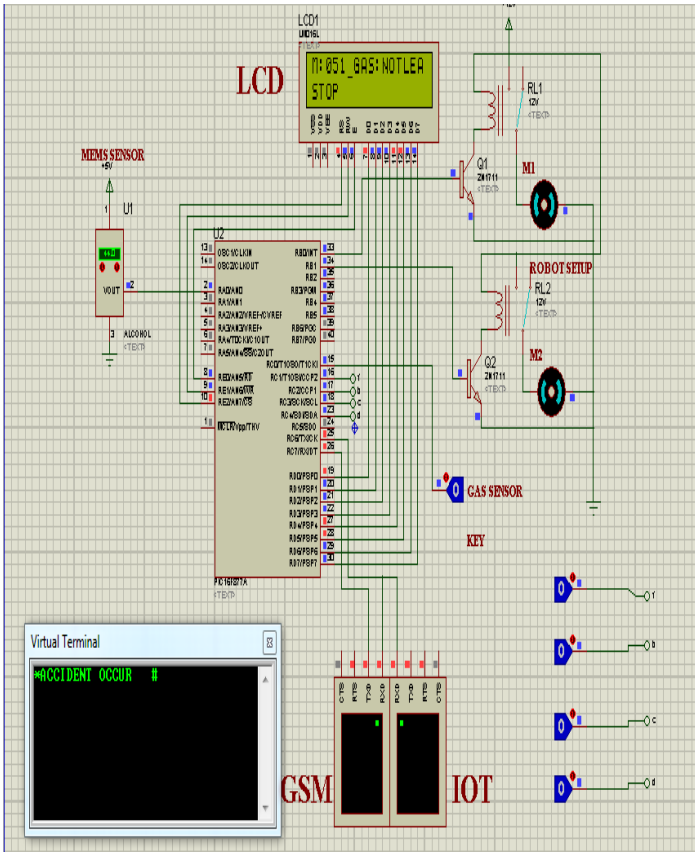

FIG :5 simulation output during accident

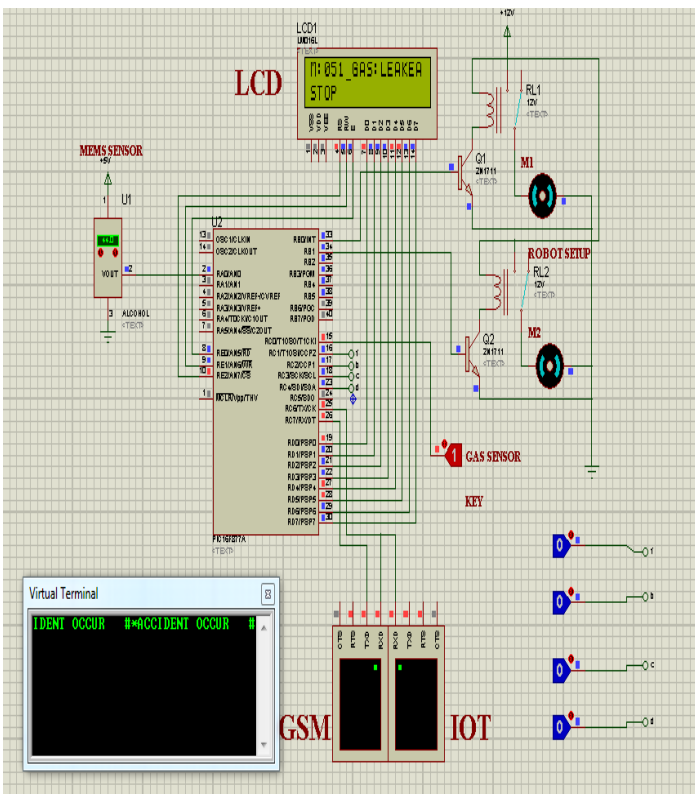

FIG :6 gas sensor



FIG: 7 pic16f877a

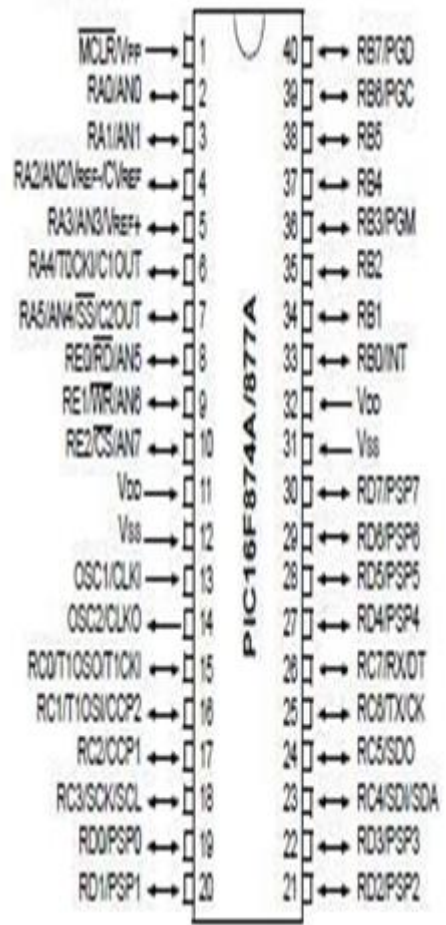

FIG :8 Pin diagram.

The PIC microcontroller PIC16f877a is very convenient to use, the coding or programming of this controller is also easier. One of the main advantages is that it can be write-erase as many times as possible because it use FLASH memory technology. It has a total number of 40 pins and there are 33 pins for input and output. An EEPROM is also featured in it which makes it possible to store some of the information permanently like transmitter codes and receiver frequencies .They are reliable and malfunctioning of PIC percentage is very less. Power conception is also very less when compared to other micro controllers. The performance of the PIC is very fast because of using RISC architecture. The PIC Microcontrollers are the world's smallest microcontrollers ,hence it is used in many electronic devices which is why we too used in our project

5.2 MQ-6 GAS SENSOR



FIG:9 Gas sensor

This is a simple-to-use liquefied petroleum gas sensor, suitable for sensing LPG concentrations in the air. The can detect gas concentrations anywhere from 200 to 10000ppm. This sensor has a high sensitivity and fast response time. The sensor's output is an analog resistance. The drive circuit is very simple; all you need to do is power the heater coil with 5V, add a load resistance, and connect the output to an ADC.

5.3 MEMS SENSOR:

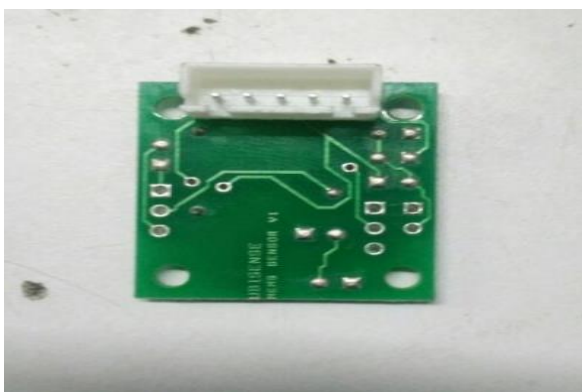

FIG:10 mems sensor

Micro-electro-mechanical Systems (MEMS) is highly applicable as MEMS Accelerometer. An accelerometer is an electromechanical device that is used to measure acceleration and the force producing it. The most commonly used accelerometer is the piezoelectric accelerometer. But, since they are bulky and cannot be used for all operations, a smaller and highly functional device like the MEMS accelerometer was used in this project.

5.4 GSM MODEM:



FIG:11 GSM modem.

GSM is a mobile communication modem; it stands for global system for mobile communication (GSM). A GSM modem is a device which can be either a mobile phone or a modem device which can be used to make a computer or any other processor communicate over a network. A GSM modem requires a SIM card to be operated and operates over a network range subscribed by the network operator.

5.5 IOT MODULE:



FIG :12 IOT module.

Internet of Things is an environment which provides the ability to transfer data over a network without requiring human-to-human or human-to-computer interaction. Data may be updated to a specific site or a social network by which the user can able to access the data.

FEATURES:

Power Supply: DC +12v 1Amp. Message Format: message or Data (Start with * and End with #) Provided with 2 links

.Data updating to a specific web site Data updating to a social network.

6.CONCLUSION

In this paper , the various sensors such as MEMS, Gas sensor(MQ-6), GSM modem, IOT are used to obtain the Vehicle Safety with dialing system and location tracker .The proposed system have been verified and demonstrated through simulation .The simulation of the proposed system is illustrated through the proteus software.

REFERENCES

- [1] Mobile Netw. Appl., vol. 22, no. 1, pp. 98–112, Feb. 2017.
- [2] IEEE Communication . Surv. uTutor., vol. 17, no. 4, pp. 1923–1940, Nov. 2015.
- [3] IEEE Wirel. Commun., vol. 23, no. 4, pp. 90–95, Aug. 2016.
- [4] IEEE Trans. Robot. Autom.,vol. 15, no. 2, pp. 343–350, Apr. 1999.
- [5] Transp. Res. C, Emerg. Technol., no. 36, pp. 13–16, Nov. 2013.
- [6] IEEE Trans. Instrum. Meas., vol. 65, no. 5, pp. 1098–1107,May 2016.