

# APPLICABILITY OF LIFI TECHNOLOGY FOR INDUSTRIAL AUTOMATION SYSTEM

A.P. Deepika<sup>1</sup>, S.Shaalini<sup>2</sup>, M.Sheela<sup>3</sup>

<sup>1</sup>Assistant Professor, Electronics and Communication Engineering, Jeppiaar SRR Engineering College, Chennai, TN

<sup>2,3</sup> Student, Electronics and Communication Engineering, Jeppiaar SRR Engineering College, Chennai, TN

\*\*\*

**Abstract** – In Previous year, constant monitoring is very difficult for people. Industrial monitor necessary more man power to monitor and control the industrial parameter such as temperature, current, voltage, gas, etc. So, Some occasion in away of technician it may occur abnormal condition. To avoid these abnormal condition we have proposed LIFI based industrial field monitoring system which continuously measuring the industrial parameter. If any abnormal condition occurs, it directly send a message to the admistrator via LIFI communication. LIFI provides transmission of data through LED light bulb. It vary in intensity faster than human eye. It is possible to encode data in light at which the LED flicker based method. To monitor the industrial parameter such as temperature sensor, current sensor, voltage sensor, gas sensor is used. It reduce the human work necessary in the industrial monitoring field by monitoring the overall industrial parameters through single PC with LIFI application.

Here input such as sensor, current sensor, temperature sensor ,gas sensor are given to ARDUINO development board. LIFI is used to send a message through LED bulb. LIFI provides uninterrupted output. This application is developed for monitor and control the machine health in industry. In existing project WIFI concept is used which is high cost and data transfer speed is 150Mbps .WIFI is difficult to transmit message to long range. The applicability of LIFI concept is implement in industrial sector itself both monitor and control the machine health. LIFI is cheaper than WIFI because free band does not need license and it uses light.

**Key Words:** LIFI, LED, temperature sensor, voltage sensor, current sensor, gas sensor

### 3. BLOCK DIAGRAM

#### 3.1. TRANSMITTER:

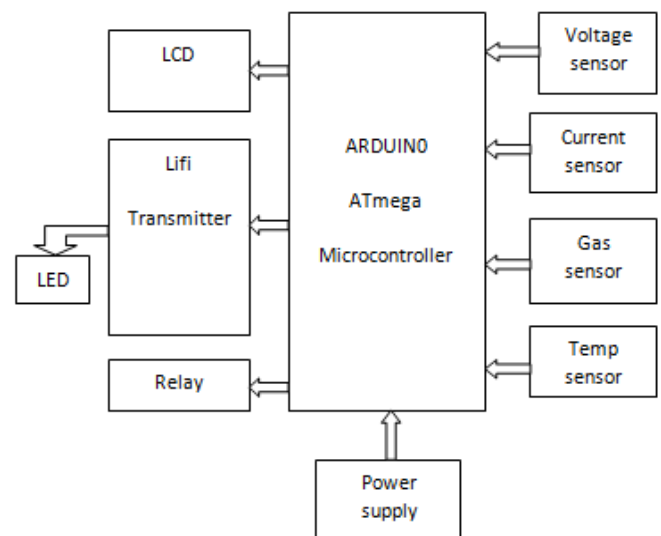

#### 3.2 RECEIVER:

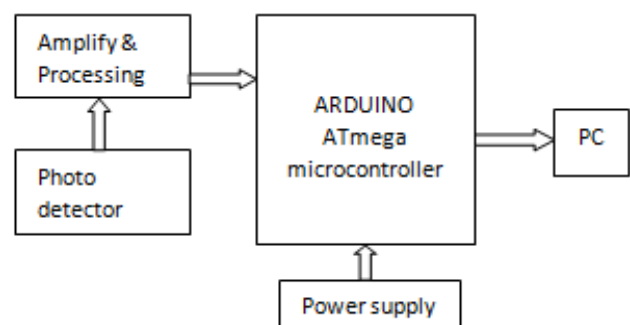

## 1. INTRODUCTION

The main objective is to design the monitoring and control system for industrial parameter using LIFI communication. The industrial parameters are not monitored and controlled properly, it occur to a abnormal condition.

Monitoring is most important in industry. Monitoring is done by sensor with most accuracy and reliability. Control process will also be handled by this LIFI communication. Arduino decodes the commands are given through LIFI with the help of LED and control the industrial devices through relays. The interfacing between LIFI transmitter and LIFI receiver is done by Arduino. This concept was taken this paper to reduce human efforts in industry.

## 2. METHODOLOGY

Our project mainly aims at alleviating the problem for the health of the machines and helps them monitor without depending on human. Now a days industrialization as increases as well as increasing population they are releasing unwanted things in environmental especially in industry. This is one of the most upcoming issues in industrial sector. The present idea of our project is monitor and control the machine health to interface LIFI with machine and help to communicate with the LIFI.

#### 4. LIFI

Here we can understand the construction and working of the LIFI model. LIFI provides transmission of message through illumination by sending data via LED light bulb that varies in intensity faster than human eye can follow. It is possible to encode data in light by varying the rate at which the flicker on and off method. The LED intensity is regulated so quickly that human eye cannot observe, so the output appears constant. LIFI means light fidelity. It provides better bandwidth, efficiency, availability and security. It has high data to transmit and accuracy.

#### 5. HARDWARE DISCRPTION

The hardware consists of various components such as ARDUINO UNO atmega 328 ,relay,16\*2 LCD, voltage sensor, current sensor, temperature sensor, gas sensor, LIFI transmitter, photo detector(LIFI receiver),external device (power distributor)DC supply of 5v

##### 5.1. ATmega328

ARDUINO UNO is a microcontroller board based on the ATmega328.It contain 14 digital pin and 6 analog pin. ARDUINO is open source board and onboard programming. It is user interface easy and connect USB cable easily. It as fraction of time send the message. Arduino Uno can be programmed with the Arduino software IDE.

(PCINT14/RESET) PC6	1	28	PC5 (ADC5/SCL/PCINT13)
(PCINT16/RXD) PD0	2	27	PC4 (ADC4/SDA/PCINT12)
(PCINT17/TXD) PD1	3	26	PC3 (ADC3/PCINT11)
(PCINT18/INT0) PD2	4	25	PC2 (ADC2/PCINT10)
(PCINT19/OC2B/INT1) PD3	5	24	PC1 (ADC1/PCINT9)
(PCINT20/XCK/T0) PD4	6	23	PC0 (ADC0/PCINT8)
VCC	7	22	GND
GND	8	21	AREF
(PCINT6/XTAL1/TOSC1) PB6	9	20	AVCC
(PCINT7/XTAL2/TOSC2) PB7	10	19	PB5 (SCK/PCINT5)
(PCINT21/OC0B/T1) PD5	11	18	PB4 (MISO/PCINT4)
(PCINT22/OC0A/AIN0) PD6	12	17	PB3 (MOSI/OC2A/PCINT3)
(PCINT23/AIN1) PD7	13	16	PB2 (SS/OC1B/PCINT2)
(PCINT0/CLKO/ICP1) PB0	14	15	PB1 (OC1A/PCINT1)

Pin diagram of ATmega328

The pins PB0-PB5,PD0-PD0-PD7 are digital pins. The PC0-PC5 are analog pins.PB6-PB7 pins are crystal oscillator pins.

##### 5.2 VOLTAGE SENSOR

Voltage sensor(LM358) is used to monitor and measures the voltage supply. It react has comparator. It compare input voltage and threshold voltage the output will be original voltage and it is given to the analog pin of ARDUINO board. It is based on resistance points pressure principle. In the case of voltage fluctuation the circuit becomes open using relay switch.



Fig-Voltage sensor

##### 5.2.1. SCHEMATIC DIAGRAM OF VOLTAGE SENSOR

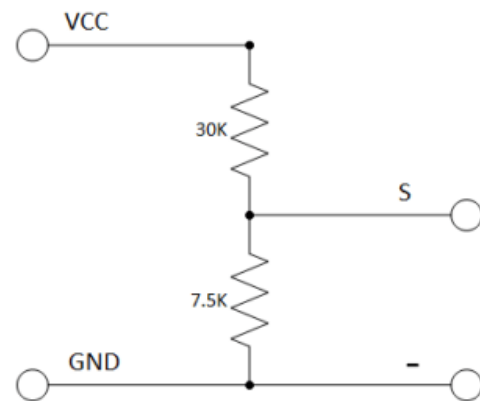

Fig-voltage sensor of schematic diagram

##### 5.3. CURRENT SENSOR

Current sensor(ACS712) is used to measure both AC and DC. It has a hall effect based linear current sensor. This sensor is used for motor control, load detection, switched mode power supplies and overcurrent fault protection. Monitoring the current flow in a device by a main powered appliance is just complicated. because continuous current flow monitoring by a circuit create current isolation in device, so we need to measure current flow without affecting the device. The popular and easy method to current sensing is hall effect.

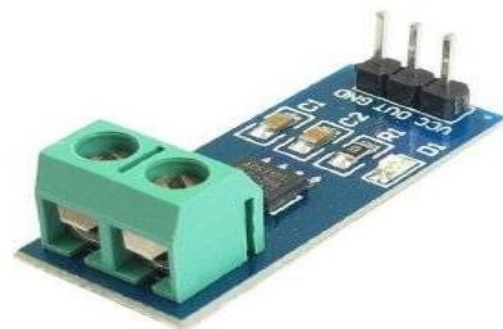
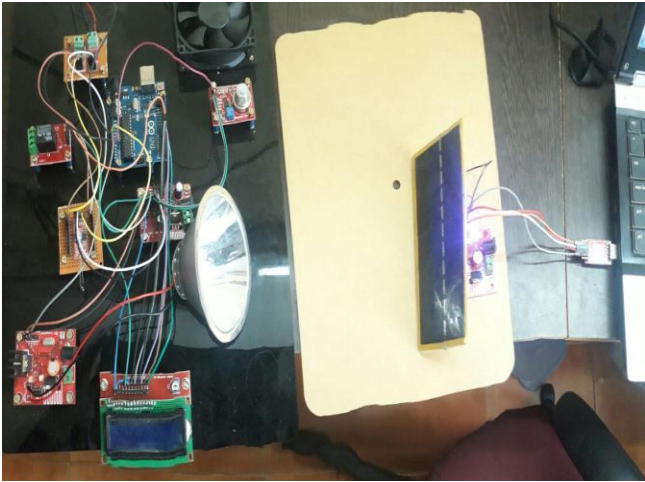

Fig-Current sensor



## HARDWARE NTERFACING



## CONCLUSION

By this project, some of the industrial parameters can be monitored continuously at regular intervals of time. A new technology called LIFI is used to deliver uninterrupted output related to the maintenance officer located anywhere at any time.

## REFERENCE

- [1] K. Chintalapudi, A. P. Iyer, and V. N. Padmanabhan, "Indoor localization without the pain," in Proc. 16th Annu. Int. Conf. Mobile Comput. Netw. (MobiCom), June .2016, pp. 173–184.
- [2] H. Lim, L. C. Kung, J. C. Hou, and H. Luo, "Zero-configuration, robust indoor localization: Theory and experimentation," in Proc. IEEE INFOCOM, Barcelona, Spain, Apr. 2016, pp. 1–12.
- [3] L. Zwirello, T. Schipper, M. Jalilvand, and T. Zwick, "Realization limits of impulse-based localization system for large-scale indoor applications," IEEE Trans. Instrum. Meas., vol. 64, no. 1, pp. 39–51, Jan. 2015.
- [4] J. C. Prieto et al., "Performance evaluation of 3D-LOCUS advanced acoustic LPS," IEEE Trans. Instrum. Meas., vol. 58, no. 8, pp. 2385–2395, Aug. 2015.
- [5] P. Lazik, N. Rajagopal, B. Sinopoli, and A. Rowe, "Ultrasonic time synchronization and ranging on smartphones," in Proc. IEEE Real-Time Embedded Technol. Appl. Symp. (RTAS), May 2015, pp. 108–118.
- [6] Prof. A. Sudan, "Performance Enhancement of Data Communication through Visible Light Communication Using On Off Keying," February 2013.
- [7] M.Kavehrad, "Sustainable Energy Efficient Wireless Applications Using Light," IEEE Common. Mag., vol. 48, no. 12, Dec. 2010, pp. 66-73.
- [8] D. C. O'Brien, "Indoor optical wireless communications: recent developments and future challenges," in Free-Space Laser Communications IX, San Diego, CA, USA, 2009, pp. 74640B-1
- [9] P. Amirshahi, M. Kavehrad, "Broadband Access over Medium and Low Voltage Power lines and use of White Light Emitting Diodes for Indoor Communications," IEEE Consumer Communications & Networking Conference, Las Vegas, Nevada, January 2006. Optical Wireless Communications Using White LED Lighting".
- [10] T.Komine and M.Nakagawa, "Fundamental analysis for visible light communication systems using LED Lights," IEEE Trans. Consumer Electronics, vol. 59, no.1, Feb, 2004.
- [11] Y. Tanaka et al., "Indoor Visible Light Data Transmission System Utilizing White LED Lights," IEICE Trans. Common. vol. E86-B, no. 8, Aug. 2003, pp. 2440–54.
- [12] M.G. Crawford, "LEDs challenge the incandescent," IEEE Circuits Devices Mag., vol. 8, pp. 24-29, Sept. 1992.
- [13] Spiro's Lour's and David Fuschelberger, "VLC Technology for Indoor LTE Planning."