

HOME AUTOMATION USING LIGHT FIDELITY TECHNIQUE

¹ASWATHA. R, ²DHARANI. C, ³KEERTHANA. N

^{1,2,3}KPR Institute of Engineering & Technology, Arasur, Coimbatore.

ABSTRACT: Li-Fi is a bidirectional, high speed and fully networked wireless communication technology similar to Wi-Fi. Li-Fi is ideal for high density wireless data coverage in confined area and for relieving radio frequency interference issues. This paper designs and presents a system implementation of new home automation system by using Li-Fi technology. The user can locally or remotely controls the system. The proposed system consists of two parts. The software implementation is done using the PIC microcontroller for controlling multiple devices. The next part is hardware which controls the multiple device according to the user's needs based on switching.

Index terms: Home automation, Li-Fi, microcontroller, LED, Photo diode.

I. INTRODUCTION

Light emitting diode acts as a medium for light based communication system to high speed Li-Fi or Light Fidelity that refers to 5G visible communication in a similar manner as Wi-Fi. Nowadays where internet has become major demand, all are in search of Wi-Fi hotspots. Li-Fi, the Life of data communication is the best alternative to Wi-Fi wireless communication. This paper is about a survey on Li-Fi technology. In visible regions, it has more capacity in terms of bandwidth. So, it will not stab the nose for other communication which uses RF (Radio Frequency), without taking its frequency bands. It provides thousand times faster than Wi-Fi and provides high security as the visible light cannot penetrate through the walls of the home, which leads to a new generation of optical wireless communication. The concept of Li-Fi data communication on fast flickering of light is not detected by the eye of human, but it is detected by the photo detector which is used to convert the ON and OFF state into binary digital data such as 0's and 1's.

II. Li-Fi

Li-Fi using visible light instead of gigahertz radio waves. Nowadays approximately 5 million mobile phones are transmitted higher than 600 terabytes of data in every month and currently there are 1.4 billion base station available that inherent more energy and there should be less than 5 percent of efficiency, this all explains that usage of wireless has been achieved maximum utility. It is free of wires and there will be no box installed as Wi-Fi. The binary numbers should be transmitted into light pulse. It can be through tiny LED bulbs on and off million of times per second. The explorers of data transmission through

blinking of LED which translates up to 10Gbps per second with the help of wireless internet. These gain come at a five-fold transits currently offering fiber optics, Luminous router is used to get the maximum gain of this technology, that have the capacity to emit the binary signals. Li-Fi is not visible to eye so it won't ever replace Wi-Fi, but it could overcome it nicely. It will be very easy in our house where every light will act as a wireless network bridge, instead of trying to find the perfect Wi-Fi router.

III. CONSTRUCTION OF A Li-Fi SYSTEM

Compared to Wi-Fi, Li-Fi is a cheap and fast optical technology. Visible Light Communication (VLC) is the basis for Li-Fi. VLC is a data communication media, which depends on visible light between 400 THz (780 nm) - 800 THz (375 nm). It acts as an optical carrier for data transmission and illumination which uses fast signals of light for transmission without wires. The major components of Li-Fi system are as follows: The transmission source for Li-Fi is the high brightness LED (white). A silicon photodiode with proper response to visible light as the receiving node. LEDs can be switched on and off to produce digital strings of different combination of 1s and 0s. To produce a new data stream, data can be encoded in the light by changing the flickering rate of the LED. The lamps can be used as a sender or source, by transmitting the data with the LED light as a signal. The LED results as a constant to the human eye by virtue of the fast flickering rate of the LED. Normal communication rate greater than 100 Mbps is possible by using multiplexing techniques with the help of high speed LEDs and the VLC data transfer rate can be raised by parallel data transmission with the help of LED (array manner) in which tie every LED sends the various data sets.

IV. PROPOSED SYSTEM

In the process of home automation through the visible light consists of both hardware and software implementation. Software implementation is done using the MPLAB software. Simulation is processed through Proteus-8 software.

One of the widely used device in this project is PIC16F877A. It is most convenient to use, the coding or programming of this controller is also easier. One of the main advantages is that it can be write erase as many times as possible because it use FLASH technology.

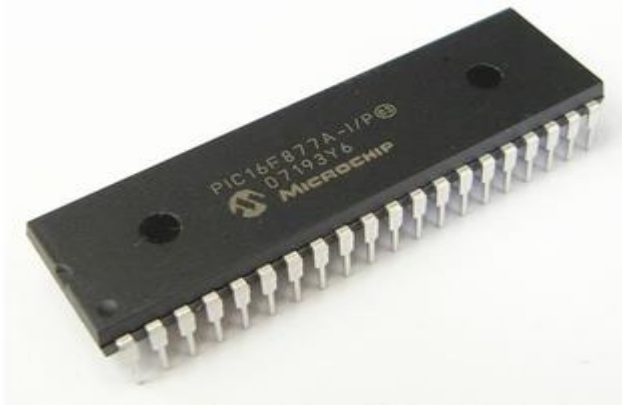

Fig:1 PIC 16F877A

A. Transmitter side

The process of data communication through visible light on the transmitter side switch keypad is given as the input signal. The microcontroller receives the signal from the keypad and generates the signal which will decide the operation of relay. In the process of voice communication, the given voice signal is converted into an electrical signal using a microphone. The light signal from the LED varies according to the intensity of voice signal. The relay will be connected to the Li-Fi transmitter which gives the data or voice to be transmitted.

Transmitter Block Diagram:

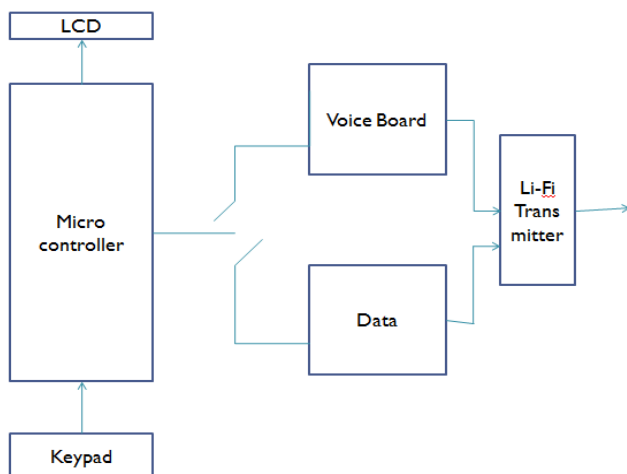

Fig:2 Transmitter block diagram

B. Receiver side:

At the receiver side, LDR will receive the light signal and generates the electrical signal according to it. In case of data transmission, the output is then fed to the microcontroller and it will activate the corresponding load for the pressed key. In case of voice communication, the electrical signal is fed to the speaker and it produces the audio which was given as input.

Receiver Block Diagram

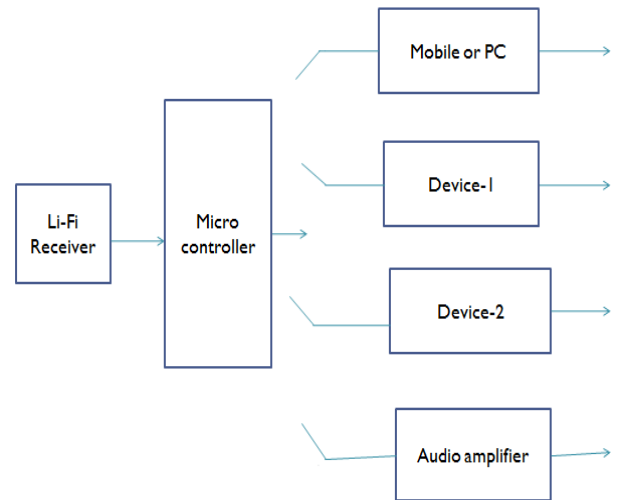

Fig3: Receiver block diagram

V. COMPARISON BETWEEN LI-FI AND WI-FI

Li-Fi is the name given to high speed wireless communication, where visible light plays a vital role. The name is derived from similarity to Wi-Fi. Wi-Fi works well within buildings and Li-Fi is unique for high density data coverage areas or rooms and for avoiding radio interference issues. Wi-Fi provides higher data rates, IEEE 802.11 in maximum implementations which provides up to 150Mbps practically, but the speed is low.

VI. APPLICATIONS OF LI-FI

1. Education systems
2. Medical Applications
3. Cheaper Internet in Aircrafts
4. Underwater applications

VII. CONCLUSION

In this paper, we discussed about Home automation using Li-Fi, which is an advanced approach on design, which controls the device. It has a wide range of applications compared to any other networks in various fields. Likewise there are some drawbacks, but can be eliminated by future research works. Li-Fi has provided the next step of invention in the world of communication, it is safe to all species including humans and progressing towards a greener, less expensive and brighter future of technologies. To provide the new way of communication channels with the help of already existing equipment and also to solve the deficiency of radio frequency bandwidth, the LI-FI should be used.

VIII. FUTURE SCOPE

- It is possible to achieve more than 10 Gbps of speed, theoretically which would allow a high-definition film to be downloaded in just 30 seconds.

IX. REFERENCE

1. Akshata M Sonna, Anjanagopan, Sailakshmi N.R, Divya S, Ambika R, "Recent Advancements in Li-fi Technology" International Journal of Electrical, Electronics and Data Communication, volume-1, issue-10, dec-2013 issued: 2320-2084.
2. G. PravinRaj, P. Prabakaran, "Implementation of Li-Fi technology for Underwater Communication through Light waves", International Journal for trends in Engineering & Technology, Vol-23, May 2017.
3. Jithender Singh, Vikash, "A New Era in Wireless Technology using Light-Fidelity" International Journal of Recent Development in Engineering & Technology, Vol-2, June 2014.
4. Jyoti Rani, Prerna Chauhan, Ritika Tripathi, "Li-Fi (Light Fidelity)-The future technology In Wireless communication||", International Journal of Applied Engineering Research, ISSN 0973-4562 Vol.7 No.11 (2012).
5. M. Thanigavel "LiFi Technology in wireless communication", International Journal of Engineering Research & Technology, October 2013.
6. Y. Rumes, Dileeka Dias, Dulanja Samudika, Lahiru Jayasinghe, "Stereo Audio Streaming via Visible Light", IEEE 2016