

# FAULT DIAGNOSIS OF A ROLLING ELEMENT BEARINGS USING ACOUSTIC CONDITION MONITORING AND ARTIFICIAL NEURAL NETWORK TECHNIQUE

Mary Jasmin Nerella<sup>\*1</sup>, Ch.Ratnam<sup>2</sup>, V.Vital Rao<sup>3</sup>

<sup>1</sup>Research Scholar, Mechanical Engineering, A.U College of Engineering (A), Visakhapatnam, India

<sup>2</sup> Professor & H.O.D, Mechanical Engineering, A.U College of Engineering (A), Visakhapatnam, India

<sup>3</sup>Deputy General Manager, Engg. Shops & Foundry Dept., Visakhapatnam Steel Plant, Visakhapatnam, India

\*\*\*

**Abstract** - Rolling Element bearings (REBs) are the common elements used in heavy rotating machinery and equipment because of their high reliability. Hence, condition monitoring and defect detection are very important for the safe running of these machines. Acoustic Emission (AE) is receiving increasing attention as a complementary method for condition monitoring of bearings as AE is very sensitive to incipient defects. This paper presents the design and development of artificial neural network based model for the fault detection of REBs using a back propagation learning algorithm and multi-layer perception neural network. The network consists of nine, ten, and one nodes in the input, hidden, and output layers, respectively. The trained system recommended that the AE technique could be used for bearing defect detection and estimation of defect size. Features vector which is one of the most significant parameters to design an appropriate neural network were extracted from analysis of acoustic signals in time domain and frequency domain methods. The statistical features of acoustic signals such as AE amplitude (dB level), RMS, Peak value, Crest factor, skewness, Kurtosis, Clearance Factor along with rpm, load were used as input to ANN. The predicted defect sizes are compared with the actual seeded defect sizes and the percentage error was minimal

inspection of bearings. Vibration based techniques are well established for the condition monitoring of rolling element bearings, although they are not so effective in detecting incipient defects in the bearing. Acoustic emission (AE) is receiving increasing attention as a complementary method for condition monitoring of bearings as AE is very sensitive to incipient defects [1]. The application of Acoustic Emission (AE) for bearing diagnosis is gaining ground as a complementary diagnostic tool; however, limitations in the successful application of the AE technique have been partly due to the difficulty in processing, interpreting and classifying the acquired data. Precisely locating and identifying incipient structural damage is of great interest of many researchers [2-5]. Bearing defects can be either distributed or local, or a combination of both. The distributed defects can be surface roughness, waviness, misaligned races, and off-size rolling elements etc., of the rolling element bearings. Localized defects such as cracks, pits and spalls are developed in the raceways, roller/ball and cage of the bearing, which generates periodic impacts occurring at ball-passing frequency (characteristic defect frequencies) and can be calculated theoretically from the bearing geometry and the rotational speed of the shaft [6]. Different condition monitoring techniques have been developed to monitor and diagnose the defects of rolling element bearings, which are based on vibration signals and the Fast Fourier transform (FFT) spectrum has been used for the signal analysis [7]. Shakya et al. investigated the effect of a defect and its severity on the observed vibration identification parameters, using vibration data acquired from the defective bearing. Time domain, frequency domain and time-frequency domain parameters were then compared based on their robustness, sensitivity to damage change and early detection of the bearing fault. Sometimes defect frequencies are not observable on the FFT spectrum, as the impulses generated by the defects are masked by noise [8]. Klein et al. focused on several bearing damage feature extraction methods by emphasizing the need for the separation of bearing signals from other excitation sources, therefore the improvement of the signal-to-noise ratio by the effective signal de-noising and extraction of the appropriate weak failure signs that may be obscured by other vibration sources and noise [9].

**Keywords:** Rolling Element Bearings, Fault Diagnosis, Condition Monitoring, ANN, Back Propagation.

## INTRODUCTION

Detection of the fault and its diagnosis are two important aspects of the condition monitoring of engineering structures. Rolling element bearings are very critical components of rotating machines find widespread domestic and industrial applications and the presence of defects in the bearing may lead to failure of machines. Hence, early identification of such defects along with the severity of damage under operating condition of the bearing may avoid malfunctioning and breakdown of machines. Defective bearings are source of vibration and these vibration signals can be used to assess the faulty bearings. Thus, the detection of these defects is of vital importance for condition monitoring and quality

Though there are varieties of machine condition monitoring techniques, Acoustic emission (AE) is a very efficient non-destructive technique for analysis, monitoring, and diagnosis of bearings. Elastic waves associated with defects on bearings subjected to different loads can propagate through the medium and be captured by AE transducer. In bearing fault diagnosis, vibration-based methods are very popular; however the signals acquired from the bearings by the transducers are distorted by the other faults and mechanical noise from the equipment. The vibration signal is not sensitive to the incipient defects in the bearings and sometimes the defect frequencies are not observable with the help of the FFT spectrum, due to the impulses generated by the defects being masked or distorted by the noise generated by other parts of the equipment. Generally, the vibration accelerometers only pick up signals below a frequency of 20 kHz. Low-frequency related problems, such as rotor unbalance, misalignment, severe damage in the bearing, rubbing, looseness etc., can be easily diagnosed with vibration analysis. AE probe can pick up signals between 100 kHz to 1 MHz in frequency; hence low frequency related problems will not interfere with the AE signals generated by the fatigue cracks, incipient damage in bearings, etc. The AE technique also provided an indication of the defect size, allowing the user to monitor the rate of degradation on the bearing that is unachievable with vibration analysis. Vibration-based techniques are effective when the defect in the bearings has already become severe. Yong et al. investigate the bearing defect AE characteristics and validates the relationship between various AE parameters and the operational condition of rolling element bearings. The AE parameters which are sensitive to the running and fault conditions have strong influence on the strain and deformation within the bearing material [10]. Cockerill et al. demonstrates the generation of acoustic emission with in cylindrical roller bearings has been effected by increased speed and load . It was found that the root mean square signal level increased significantly with increasing speed whereas increasing load had a far weaker effect. And assess the potential of acoustic emission by providing an insight into the bearing's behavior under normal operation and provide early indication of bearing failure [11]. Luis et al. enhanced envelope method which is able to detect incipient defects with 9 dB lower SNR than traditional envelope analysis. This method is to identify localized defects in bearing incipient defect detection stage, in which the signal-to-noise ratio (SNR) is extremely low [12]. Caesarendra et al. applied acoustic emission (AE) hit parameters as the Monitoring parameters for the detection of impending failure of low speed slew bearings [13]. Rao et al. describes the comparisons between AE and VA over a range of speed and load conditions at gradual increase of defect size are presented and concluded that AE method is

superior to identify the severity of defect [14]. Hence, based on the above research AE is considered for further investigation. Based on the vibration analysis and acoustic emission of rolling element bearings, many research papers have been published but in most of the papers it is observed that the artificial defects are of different sizes and forms. Hence, the association between defect sizes and its vibration or AE parameter has to be proven. In this paper, an attempt has been made to establish a correlation between the defect size and the AE amplitude of a specific bearing, with the help of artificial neural networks. The MHC-memo pro (Holroyd make) AE instrument works on the acoustic emission principle on operating the high frequency stress waves. This instrument recorded AE time wave signal on defective cylindrical roller bearings, running with gradual increase of seeded defect size, speed and load, and the data file was processed through FFT with AE lab software, which is supplied with the AE instrument. Considering the AE amplitude dB level data, rpm, load along with calculated statistical parameters such as RMS, Peak value, Crest factor, skewness, Kurtosis, Clearance Factor, an ANN multilayer perception model is used to predict the defect size of the defective bearing.

Acoustic emission (AE) or stress wave emission is the phenomenon of transient elastic wave generation in the materials which is subjected to stress at a certain level, a rapid release of strain energy takes place in the form of elastic waves which can be detected by transducers placed on it. The main sources of acoustic emission in metals are Plastic deformation and growth of cracks. AE is an important tool for condition monitoring through non-destructive testing technique for the detection of crack propagation and failure detection in rotating machinery. The signal is generated and measured in the frequency range which is greater than 100 kHz. AE monitoring has an added advantage that it can even detect the growth of subsurface cracks whereas vibration monitoring can normally detect a defect when it appears on the surface [15]. AE method is an NDT method used in the health management of structures, such as pressure vessels, reactors, bridges, etc, and has recently been used in bearing fault diagnosis. The interaction of surface asperities and impingement of the bearing rollers over the seeded defect on the outer race will generate AE. Significant progress in the capabilities of acoustic instrumentation, together with signal processing techniques, has made it possible to extract useful diagnostic information from acoustic signals. The main advantage of AE is that it offers high SNR, which is required for the precise damage detection.

The use of AE for bearing defect diagnosis is reported in various investigations. Dong et al. deals with a signal processing method for AE signal by envelope analysis with

discrete wavelet transforms is proposed [16]. Hemmati et al. find effective and reliable health monitoring technique and advanced signal processing to detect and diagnose the size and location of incipient defects. The algorithm is based on optimizing the ratio of Kurtosis and Shannon entropy to obtain the optimal band pass filter utilizing wavelet packet transform (WPT) and envelope detection [17]. Mba centered on the application of the Acoustic Emission technique for identifying the size of a defect on a radially loaded bearing [18]. Ferrando et al. proposes a novel envelope analysis method able to identify localized defects with 9 dB lower SNR in an incipient stage [19]. Ratnam et al. reported in this paper a comparative values obtained by the application of the AE technique and Probes for identifying the presence of a defect on a radially loaded bearing [20]. Entezami et al. considers the use of microphones and recording equipment to acoustically detect bearing failures at an early stage. This investigation first shows the development of testing equipment and algorithms for acoustic condition monitoring of rolling bearings under ideal conditions. Work on development of this research into a working line side system is then presented, including real world measurements of passing trains [21]. Salah et al. reviews AE based condition monitoring with particular emphasis on rotating and reciprocating machinery applications [22]. Mohammed et al. investigated the effect of defect size, operating speed and loading conditions on statistical parameters of AE signals using design of experiment method to choose the most sensitive parameters for diagnosing incipient faults and defect growth on rolling element bearings [23]. Santos et al. discuss about the influence of transverse crack sizes on the acoustic emission (AE) signals rendered in vibration tests performed on cracked rotors. The experimental result indicates values of kurtosis and skewness estimated for the AE signals used to identify the crack size [24]. Arundhat, the performance of Time domain parameters such as Kurtosis, crest factor etc. are considered for different conditions of operation of SKF 6205 bearing. Defects in rolling element bearings are detected using frequency domain approach and compared for defect free bearings and defective bearings [25].

**Artificial neural networks** are also called as neural nets, artificial neural system, parallel distributed processing system and connectionist system [26]. Hosseini made a review on optimization techniques in solving of optimization of problems. They concluded that the ANN is one of the tools that perform effectively in optimization [27]. Vector  $x$  is used to represent inputs and vector  $w$  is used to represent the synapses efficiencies. Therefore the magnitude of neuron output is calculated with the following formula [28].

$$y = f\left(\sum_i \omega_i x_i\right) = f(\omega \cdot x) = f(\omega^T x)$$

Artificial neural network (ANN) is an interconnected network of models based on the biological learning processes of human brain. Training-and-learning are two important factors in ANN. There are a number of applications of the ANNs in regression analysis, robotics, data analysis, pattern recognition and control. ANN architecture has evolved to accommodate even the most complex problem. In this investigation, a multilayer feed forward back propagation (MLP) architecture is employed. The reason for choosing this architecture is because it is most commonly used and has been successful for various applications [29]. ANN is an interconnected group of artificial neurons. These neurons use a mathematical or computational model for information processing. ANN is an adaptive system that changes its structure based on information that flows through the network. The structure of neurons in a neural network is known as the network architecture [30]. It consists of two steps which are known as forward pass and backward pass [31]. The ANN approach enables us to determine the effects of various parameters of the vibrations by conducting the experiments. The output values point out that defect size, speed, load, unbalance, and clearance influence the vibrations significantly [32]. ANN is self-possessed large number of neurons working simultaneously to solve a specific problem [33]. The number of input and output layer nodes is generally suggested by the dimensions of the input and the output spaces, and determining the network complexity is again very important. Too many parameters lead to poor generalization (over fitting), and too few parameters result in inadequate learning (under fitting) [34]. Rao et al. used Artificial Neural Networks (ANN) multilayer perception model with back-propagation algorithm, with input parameters of Load, Revolutions Per Minute (RPM) and vibration rms velocity and output is seeded defect size. The ANN was trained with data sets of number of test runs conducted and predicted the defect size. The predicted values were compared with the actual seeded defect size and found the error was approximately 3.90% [35].

## EXPERIMENTAL SYSTEM

The schematic diagram in Figure 1 represents a bearing test that is designed to accomplish the requirements of the present research and future research in this area. This investigate involves running the test-rig under specific speed and load parameters with various sizes of seeded defects on test bearings, from which AE signals are acquired.

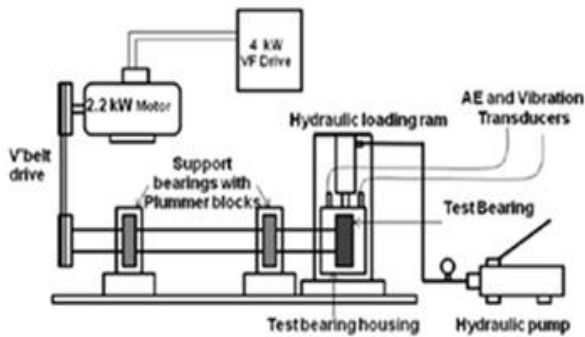

Figure1. Experimental test set-up



Figure 4. Bearing Test Rig with Probes



Figure 2. Cylindrical roller bearings

In this experimentation, cylindrical roller bearings, N312 with normal clearance are used shown in Figure 2. The reason for selection of this bearing is that its outer race can be easily separated, to provide defects of the outer race from inside. The geometric details of the test bearing shown in figure 7 are as follows.

Table 1: Geometric parameter of the bearing NTN N312

di	Inner diameter	60mm	Dp	Pitch circle diameter	96mm
do	Outer diameter	130mm	$\alpha$	Contact angle	0°
w	Width	31mm	m	Mass	1.80 kg
Z	Number of rollers	12	N	Speed Range	10-3000 r/min
d	Roller dia	18mm	L	Max load	16 kN

The test-rig (Figures 3 and 4) consists of six major parts: a shaft, support bearings, a bearing block with a test bearing, 2.2 kW three phase induction motor, 4 kW variable frequency drive for speed control and a vertical hydraulic arm for applying load radially.

A total of five test bearings are used in this investigation. Various defects sizes of width such as 0.3 mm, 0.5 mm, 0.7 mm, 0.9 mm and 1.1 mm are seeded inside the outer race with wire cut Electrical Discharge Machining (EDM) shown in Figure 5 & 6.



Figure 3. Bearing Test Rig

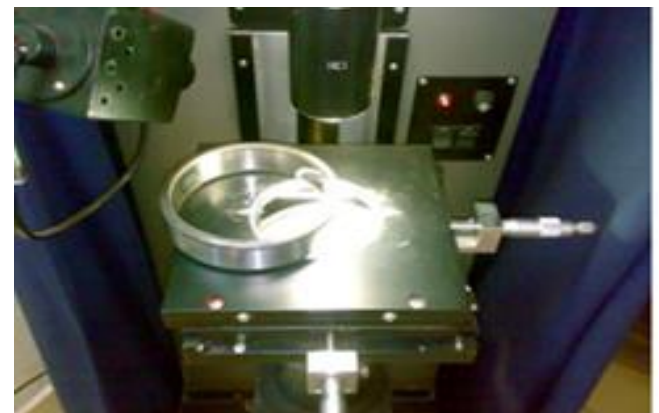

Figure 5. Defect cutting on wire EDM



Figure 6. Outer race seeded line defect (0.5 mm width)



Figure 7. Test bearing

For acoustic emission data acquisition, an MHC-Memo Pro (manufactured by Holroyd) AE instrument with a magnetic mount sensor of model 1030 Mag is used. The AE sensor is resonant piezoelectric at 100 kHz frequency 24 dB gain. This instrument recorded the time wave of 2048 samples of data per second to enable a repetition frequency spectrum to be calculated. Each AE envelope spectrum covers the frequency range of 0 Hz to 1000 Hz and is representative of one second period. Test runs are conducted on the test-rig for a consistency check of the acquired data. In first run, a healthy test bearing was accumulated and had left for several hours to stabilize with minor adjustments to the test-rig. Further, the unhealthy bearings were assembled on the test-rig and the seeded defect is positioned at the top where the load is applied radially through the hydraulic arm. All the test runs are conducted at two loads in 2 kN and 4 kN at different speeds varying from 300 to 1500 RPM in six steps. In the present work, AE signal data was recorded in mV for all test runs. The AE signals were processed through FFT with the help of AE laboratory software, which is supplied with the AE instrument. Even though there are many signatures of AE signals such as amplitude, duration, counts and signal energy, amplitude is used in the instrument MHC-Memo Pro in this experimentation, which allows for the measuring of amplitude in the signal. Time waves and frequency spectra for all test runs are analyzed in detailed.

The AE time wave and frequency spectrum of one of the test runs conducted shown in figure 8, in which the peaks raised at outer race defect frequency 121.98 Hz (BPFO) and its harmonics only and no clear peaks were observed in figure 8(a). In the enlarged time wave shown in figure 8(b), 12 impacts were observed in 0.1 s, which matches the BPFO. The highest peak amplitude in the frequency spectrum directly shows the defect intensity in figure 6(c).

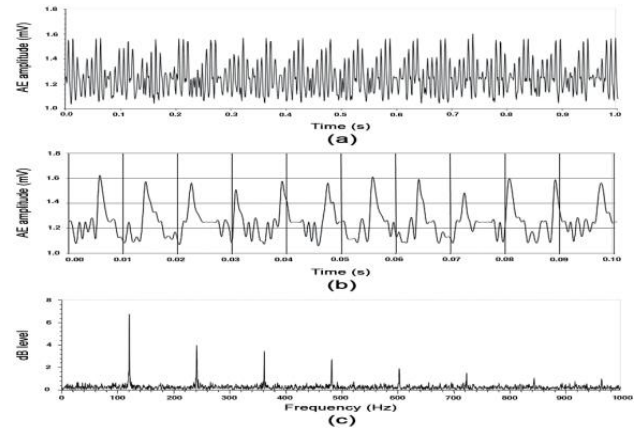

Figure 8. AE: (a) time wave; (b) enlarged time wave; and (c) frequency spectrum of test conditions L2-D4-S6.

### EXPERIMENTAL RESULTS AND DISCUSSION

The rolling element bearing defect produces certain frequencies that depend on rolling element bearing geometry, number of rolling element, and shaft speed which is shown in Figure.9.

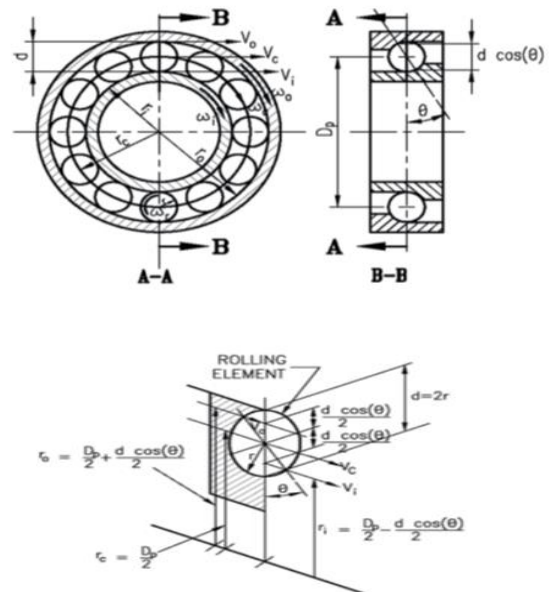

Figure 9. Schematic diagram of bearing geometry

These frequencies are expressed in Eqs.

$$FTF = \frac{1}{2}(f_i) \left(1 - \frac{d \cos \theta}{D_p}\right)$$

$$BPFO = \frac{Z}{2}(f_i) \left(1 - \frac{d \cos \theta}{D_p}\right)$$

$$BPFI = \frac{Z}{2}(f_i) \left(1 + \frac{d \cos \theta}{D_p}\right)$$

$$BSF = \frac{D_p}{2d}(f_i) \left(1 - \left(\frac{d \cos \theta}{D_p}\right)^2\right)$$

Where,

FTF = Fundamental Train Frequency

Dp = Pitch diameter

BPFO = Ball Pass Frequency of the Outer race

fi = Rotation frequency of inner race

BPFI = Ball Pass Frequency of the Inner race

Z = Number of rolling elements

BSF = Ball Spin Frequency

d = diameter of rolling element

Table-2: Defect frequencies

rpm	Characteristic defect frequency in Hertz			
	FTF	BSF	BPFI	BPFO
500	3.38	21.43	59.35	40.61
700	4.74	30.03	83.15	56.89
900	6.09	38.59	106.88	73.13
1100	7.45	47.16	130.60	89.36
1300	8.80	55.76	154.40	105.64
1500	10.16	64.32	178.13	121.98

A total of five test bearings of various defects sizes of width such as 0.3 mm, 0.5 mm, 0.7 mm, 0.9 mm and 1.1 mm are seeded inside the outer race with a depth of 0.3 mm is maintained in the defects of all test bearings. All of the test runs are conducted at two different loads, 2 kN and 4 kN, and at speeds varying from 300 rpm to 1500 rpm in six steps. Table 3 shows the test program used to carry out the experiments. 60 different experiments were planned and for each experiment at least two test runs were conducted.

Table 3. Test program

Load (kN)	Defect size width (mm)	Speed (rpm)
L1=2	D1= 0.3	N1=500
L2=4	D2=0.5	N2=700
	D3=0.7	N3= 900
	D4=0.9	N4=1100
	D5=1.1	N5=1300
		N6=1500

In Table 4, the theoretical and actual BPFO, at different speeds for a given N312 bearing with 0.5 mm defect size at 4 kN load, is presented. Many investigators in vibration analysis observed that the Actual BPFO is less than the theoretical defect frequencies due to slippage and skidding of rolling elements while running in their path [36,37]. The same tendency was seen in AE analysis and observed as the speed is increasing, the difference of theoretical and actual BPFO increased.

Table 4: Theoretical and actual BPFO in AE spectra

rpm	Theoretical BPFO	D2		Difference in BPFO (Hz)
		L2		
		dB level	Actual BPFO	
N1	40.61	2.04	40.404	0.206
N2	56.89	3.43	56.608	0.282
N3	73.13	4.32	72.224	0.906
N4	89.36	5.84	88.328	1.032
N5	105.64	4.21	104.342	1.298
N6	121.98	5.07	120.536	1.344

When the defect width size is very small the rolling element can easily roll over the defect, hence there is not much obstruction to the rolling motion and therefore the force exerted by the rolling element over the defect edge is very small. Thus, there is little disturbance in the defect area of the outer race and the stress caused is negligible. As the defect size increases, the fault edge obstructs the rolling motion of the rolling element and its velocity decreases momentarily. There is a greater change in momentum and so there is more impact on the defect from the rolling element. Due to an increase in force the stress over the defect area increases, this may lead to an extension of the defect. The stress may even reach the breaking point of the material, which can lead to an increase in the defect size. Due to this change in energy released at the point of defect in the form of stress waves, these were captured by the AE probe. In AE frequency spectra, it is observed that the peaks raised at BPFO and maximum amplitude are recorded.

### FEATURE SELECTION

The time and frequency domain signals used to perform fault diagnosis by analyzing acoustic signals obtained from the experiment. Statistical methods have been widely used can provide the physical characteristics of time and frequency domain data. Statistical analysis of acoustic signals yields different descriptive statistical parameters. Fairly a wide set of parameters were selected as the basis for the study. They are root mean square (RMS), peak value (Pv), crest factor(CrF), Skewness, kurtosis, Clearance Factor(ClF) [38,39]

**Root mean square:** Root mean square (RMS), measures the overall level of a discrete signal. RMS is a powerful tool to estimate the average power in system vibrations. A substantial amount of research has employed RMS to successfully identify bearing defects using accelerometer and AE sensors [40].

$$RMS = \sqrt{\frac{1}{N} \sum_{n=1}^N f_n^2}$$

Where N is the number of discrete points and n represents the signal from each sampled point.

**Peak value:** Peak value is measured in the time domain or frequency domain. Peak value is the maximum acceleration in the signal amplitude

$$P_v = \frac{1}{2} [\max(f_n) - \min(f_n)]$$

**Crest factor:** Crest factor is the ratio of peak acceleration over RMS.

$$Crest\ Factor = \frac{P_v}{RMS}$$

**Skewness:** Machined or ground surfaces in bearings show a random distribution of asperities that are commonly described with the normal distribution function. For this reason, various statistical moments can describe the shape of distribution curves therefore, assessing bearing surface damage level. Equation defines the third moment or skewness as [38]

$$Skewness = \frac{\frac{1}{N} \sum_{n=1}^N (f_n - \bar{f})^3}{RMS^3}$$

Where  $\bar{f} = \mu$  is the mean value.

**Kurtosis:** The fourth moment, normalized with respect to the fourth power of standard deviation is quite useful in fault diagnosis. This quantity is called kurtosis which is compromise measure between the intensive lower moments and other sensitive higher moments

$$Kurtosis = \frac{\frac{1}{N} \sum_{n=1}^N (f_n - \bar{f})^4}{RMS^4}$$

**Clearance Factor:** Clearance factor is dependent on peak value.

$$Cl_f = \frac{P_v}{\left(\frac{1}{N} \sum_{n=1}^N |f_n|\right)^2}$$

## COMBINED ACOUSTIC EMISSION WITH NEURAL NETWORK MODEL

As investigated earlier, the test program shown in Table 3, several experiments were planned and for each experiment at least two test runs were conducted. The same AE amplitude (dB level) is observed in the two successive test runs. For some experiments, test runs were conducted three to four times to achieve a consistency. A total of 144 test runs were conducted. In the acoustic emission analysis of the damaged bearing, the damage can be detected in its incipient stage but the defect size cannot be predicted. Hence, ANN is used to learn the behavior of a specific fault in the bearing and correlate the obtained AE values with the given parameters to the defect size.

As per[41], the advantages of the usage of neural networks for predictions and they are able to learn from examples after their learning is finished, they are able to recognize hidden and strong non-linear dependencies, even when there is a significant noise in the training set. When input data is adjusted to designate shape, it is divided into three sets - training set (learning), validation set and testing set. The default setting of the ratio as per the statistical program is: 70% of the input data is training set, 15% validation set and 15% testing set. To summarize, the training set is used for creating a model, the validation set for verifying the model and the testing set for testing the usability of the model.

Feed-forward multi-layer perceptron architecture was used to estimate the bearing defect size shown in figure 8. The ANN model was constructed with three layers such as input layer, output layer and one hidden layer. The input layer consist of nine neurons such as speed, load, amplitude level, RMS, Peak value, Crest factor, skewness, Kurtosis, Clearance Factor and the output layer consists of one neuron, i.e., defect size. The input information was transmitted to output layer through the neurons of hidden layers. Number of hidden layers and neurons in each hidden layer are determined by examining different neural networks on trial and error method.

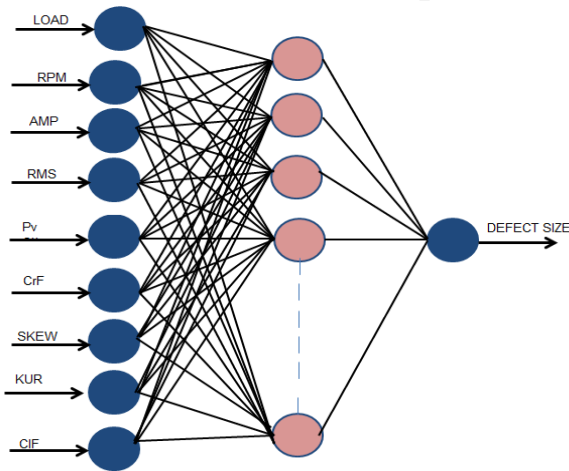

Figure10. ANN topology (9-10-1)

Learning or training of network is a process which consists of adapting weights to the connections between neurons in each layer. The learning of neural network is done with feed forward back propagation algorithm as shown in Figure. 10. The red line, blue line, green line and orange lines in the graph represent maximum example error, minimum example error, average example error and average validating error respectively. The learning graph shown in figure 9 is constructed between target error and learning cycles, with learning cycles on X axis and target error on Y axis. The neural network was trained with 53 samples and validated with 6 samples. The process of learning was stopped after 25,000 cycles when the average training error is less than target error which was set as 0.001. Here, the average training error is less than target error of 0.01. As shown in the Figure. 11, the blue line, yellow and green lines are found to be below 0.01. The network is trained at 0.6 learning rate and at the momentum of 0.8. The EasyNN-plus version 8.0 software

[42] was used to construct the ANN model and it has taken weights for the connection as 90 for the connections between input layers and hidden layer, 10 for the connections between hidden layer and output layer.

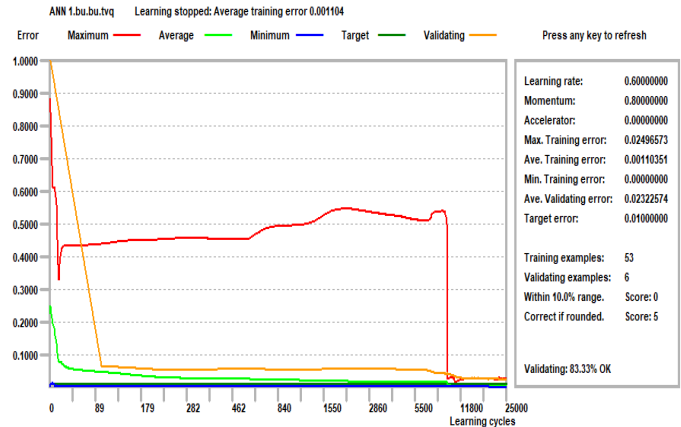

Figure 11. Learning progress graph with maximum, average and minimum training error

After training the network, fault size predicted at required speed, load, AE amplitude level, RMS, Peak value, Crest factor, skewness, Kurtosis, and Clearance Factor is given in the Table 5. The calculation of percentage error between the actual defect size and its predicted size shows an average defect size error of 6.90%, proving that the predicted values are very close to the experimental values. The result shows that reliability of the proposed network model in predicting the bearing defect size in the given conditions. Figure 12 shows a graph of comparison between the actual and the predicted defect sizes of testing data.

Table 5. Experimental values and the predicted values of defect size in testing (AE)

S.No	Load (KN)	rpm	Amplitude (dB level)	rms	Peak value	Crest Factor	Skewness	Kurtosis	Cl factor	Seeded Defect size(mm)	Predicted Defect Size(mm)	% error
1	2	500	1.8	0.89	0.27	0.33	0.0004	0.0001	0.05	0.5	0.5343	6.42
2	2	900	3.75	0.99	0.27	0.28	0.0007	0.0002	0.08	0.7	0.6967	0.47
3	4	900	4.32	0.95	0.23	0.25	0.0005	0.0002	0.07	0.5	0.6846	26.96
4	4	500	3.04	0.84	0.3	0.36	0.0004	0.0002	0.07	0.9	0.8942	0.64
5	4	1500	11.8	1.26	0.31	0.25	0.0009	0.0003	0.13	1.1	1.0999	0.01
<b>Average of % error</b>												6.90



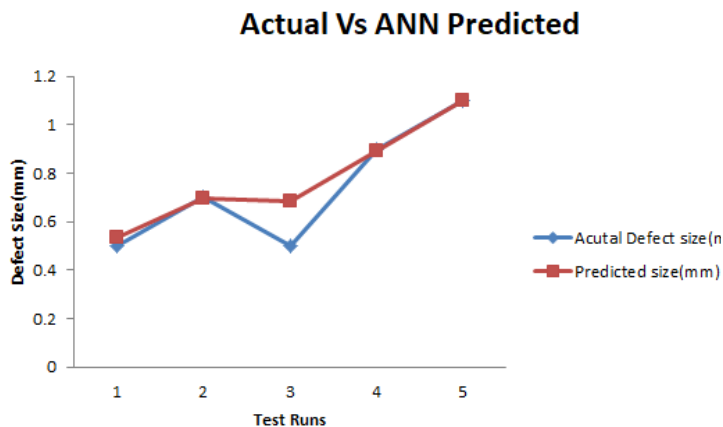

Figure12. Defect size comparison with actual versus ANN predicted values

## 6. CONCLUSION

The experiments were carried out on Rolling Element Bearings, to estimate defect size with six levels of speed, five levels of defect size and two levels of load. AE time wave signals acquired with an AE probe are analyzed through FFT with AE lab software. Easy NN plus software was used to create the neural network (9-10-1) and was trained with 53 test runs of data and validated with 6 examples. Statistical model ANN was developed to predict defect size. It was observed that there is near relation between experimental data and predicted values for AE level (6.90% of error).

## REFERENCES

1. Bouchra Abou El Anouar, et al., "A comparative experimental study of different methods in detection and monitoring bearing defects" International Journal of Advanced Scientific and Technical Research, Issue 7 volume 1, January - February 2017.
2. Pankaj Gupta, M. K Pradhan, "Fault detection analysis in rolling element bearing: A review", Materials Today: Proceedings 4, 2085-2094, 2017.
3. C.Senthilraja, L.Vinoth, "A Review on Fault Diagnosis of Ball Bearing Using Sound and Vibration Signals" International Journal of Innovative Research in Science, Engineering and Technology, Vol. 4, Special Issue 13, December 2015.
4. Saleem Riaz, Hassan Elahi, "Vibration Feature Extraction and Analysis for Fault Diagnosis of Rotating Machinery-A Literature Survey", Asia Pacific Journal of Multidisciplinary Research, Vol. 5, No. 1, February 2017.
5. Viet Tra, Jaeyoung Kim, "Incipient fault diagnosis in bearings under variable speed conditions using multiresolution analysis and a weighted committee machine "J. Acoust. Soc. Am. 142 (1), July 2017.
6. Harsh Patidar, "Study of detection of defects in rolling element bearings using vibration and acoustic measurement methods- A Review", International Journal of Mechanical Engineering Research & Technology, Vol. 1, No. 1, July, 2015.
7. N. Tandon , A. Choudhury , "A review of vibration and acoustic measurement methods for the detection of defects in rolling element bearings", Tribology International 32 , 469-480, 1999.
8. P Shakya, A K Darpe and M S Kulkarni , "Vibration-based fault diagnosis in rolling element bearings: ranking of various time, frequency and time-frequency domain data-based damage identification parameters", The International Journal of Condition Monitoring | Volume 3 | Issue 2 | October 2013.
9. R Klein, E Masad and I Winkler , "Methods for bearing feature extraction", The International Journal of Condition Monitoring | Volume 2 | Issue 2 | December 2012.
10. Yongyong He , et al, "Defect Diagnosis for Rolling Element Bearings Using Acoustic Emission", Journal of Vibration and Acoustics, DECEMBER 2009, Vol. 131, DECEMBER 2009.
11. A Cockerill, et al, "Determination of rolling element bearing condition via acoustic emission" Proc IMechE Part J: J Engineering Tribology 0(0) 1-12 , IMechE 2016.
12. Juan Luis Ferrando Chacon, et al, A novel approach for incipient defect detection in rolling bearings using acoustic emission technique, Applied Acoustics 89, 88-100, 2015.
13. WahyuCaesarendra, et al, Acoustic emission based condition monitoring methods : Review and

- application for low speed slew bearing, *Mechanical Systems and Signal Processing* 72-73, 134-159, 2016.
14. V.V. Rao , Ch. Ratnam , “A Comparative Experimental Study on Identification of Defect Severity in Rolling Element Bearings using Acoustic Emission and Vibration Analysis”, Vol. 37, No. 2 , 176-185, (2015).
  15. Tandon N, Choudhury A. Application of acoustic emission technique for the detection of defects in rolling element bearings. *Tribol Int*,33:39-45, 2000.
  16. DongSik Gu et al, “Detection of faults in gearboxes using acoustic emission signal”, *Journal of Mechanical Science and Technology* 25 (5) , 1279-1286, 2011.
  17. Farzad Hemmati et al, “Rolling element bearing fault diagnostics using acoustic emission technique and advanced signal processing”, *Proc IMechE Part J: J Engineering Tribology*, Vol. 230(1) 64-77, 2016.
  18. D. Mba, “The Use of Acoustic Emission for Estimation of Bearing Defect Size” *J Fail. Anal. and Preven.* 8:188-192, 2008.
  19. Juan Luis Ferrando Chacon et al, A novel approach for incipient defect detection in rolling bearings using acoustic emission technique, *Applied Acoustics* 89 , 88-100, 2015.
  20. V. Vital Rao, Ch. Ratnam, “Study of fault in outer race of Roller Bearings using Acoustic emission and Vibration analysis”, *International Journal of Engineering Science Invention (IJESI)* ISSN (Online): 2319 - 6734, ISSN (Print): 2319 - 6726.
  21. M. Entezami et al, “Acoustic Analysis Techniques for Condition Monitoring of Roller Bearings”, 6th IET Conference on Railway Condition Monitoring (RCM 2014), 2014 page 5.1.3.
  22. Salah M. Ali Al-Obaidi et al, “A Review of Acoustic Emission Technique for Machinery Condition Monitoring: Defects Detection & Diagnostic” *Applied Mechanics and Materials* Vols. 229-231 pp 1476-1480, 2012.
  23. Anbo Ming et al , “Detection of incipient cavitation and the best efficiency point of a 2.2MW centrifugal pump using Acoustic Emission”, The 26th European conference on Acoustic Emission testing, EWGAE, Volume: ISBN 3-931381-58-7, August 2004.
  24. Santos Pimentel Junior et al, Acoustic Emission Tests on the Analysis of Cracked Shafts of Different Crack Depths” 23rd ABCM International Congress of Mechanical Engineering, December 6-11, 2015.
  25. Arundhati Garad et al, “Analysis of Vibration Signals of Rolling Element Bearing with Localized Defects” *International Journal of Current Engineering and Technology*, Vol.7, No.1 ,Feb 2017.
  26. Dr. Jigar Patel, “Fault Diagnostics of Rolling Bearing based on Improve Time and Frequency Domain Features using Artificial Neural Networks”, *International Journal for Scientific Research & Development* | Vol. 1, Issue 4, 2013.
  27. Hosseini, S., & Al Khaled, A. A survey on the imperialist competitive algorithm metaheuristic: Implementation in engineering domain and directions for future research. *Applied Soft Computing*, 24, 1078-1094, 2014
  28. Kishan,M., Chilukuri, K. M.,&Sanjay,R. Elements of artificial neural networks. Cambridge: The MIT Press, 1997.
  29. Zahari Taha & Khusnun Widiyati, “Artificial neural network for bearing defect detection based on acoustic emission”, *Int J Adv Manuf Technol* 50:289-296, 2010.
  30. Sukhjeet Singh and Navin Kumar, “Rotor Faults Diagnosis Using Artificial Neural Networks and Support Vector Machines”, *International Journal of Acoustics and Vibration*, Vol. 20, No. 3, pp. 153-159, 2015.
  31. H. K. Srinivas, “Application of Artificial Neural Network and Wavelet Transform for Vibration Analysis of Combined Faults of Unbalances and Shaft Bow”, *Adv. Theor. Appl. Mech.*, Vol. 3, , no. 4, 159 - 176, 2010.

32. R. A. Kanai et al, "Experimental-Based Fault Diagnosis of Rolling Bearings Using Artificial Neural Network", *Journal of Tribology, ASME*, Vol. 138, JULY 2016.
33. D.H. Pandya, S.H. Upadhyay, S.P. Harsha, ANN based fault diagnosis of rolling element bearing using time-frequency domain feature, *International Journal of Engineering Science and Technology*, Vol. 4 No.06 June 2012.
34. B.K.N Rao, P. Srinivasa Pai and T.N. Nagabhushana, Failure Diagnosis and Prognosis of Rolling – Element Bearings using Artificial Neural Networks: A Critical Overview, 25th International Congress on Condition Monitoring and Diagnostic Engineering, *Journal of Physics: Conference Series* 364, 012023, 2012.
35. Vana Vital Rao, Chanamala Ratnam, Estimation of Defect Severity in Rolling Element Bearings using Vibration Signals with Artificial Neural Network, *Jordan Journal of Mechanical and Industrial Engineering*, Volume 9 Number 2, Pages 113 – 120, April.2015.
36. V Venkatasubramanian and K Chan, 'A neural network methodology for process fault diagnosis', *Journal of AIChE*, Vol 35, No 12, pp 1993-2002, 1989.
37. C T Chang and M L Wang, 'Structural damage detection using an iterative neural network', *Journal of Intelligent Material Systems and Structures*, Vol 11, No 1, pp 32-42, 2000.
38. Sorav Sharma, "Fault Identification in Roller Bearing using Vibration Signature Analysis", Master's Thesis, Department of Mechanical Engineering, Thapar University, Patiala, 2011.
39. M. Barakat, M. El Badaoui, F. Guillet, "Hard competitive growing neural network for the diagnosis of small bearing faults", *Mechanical Systems and Signal Processing* 37 (2013) 276–292.
40. Abhinay V. Dube, L.S.Dhamande, P.G.Kulkarni, "Vibration Based Condition Assessment of Rolling element Bearings With Localized Defects", *International Journal of Scientific & Technology Research* Volume 2, Issue 4, April 2013.

41. O Krejcar, 'Utilisation of C# neural networks library in industry applications', *E-Technologies and Networks for Development*, First International Conference Proceedings, ICeND, Dar-es-Salaam, Tanzania, pp 61-70, 2011.
42. EasyNN-plus, Version 8.0, Neural Planner Software Ltd, England, UK. Available online: <http://www.easynn.com>.

## BIOGRAPHIES



Nerella Mary Jasmin\* received her ME degree from S.R.K.R Engineering college, Bhimavaram, Andhra Pradesh, India. Currently she is a research scholar in Andhra University College of Engineering(A), Visakhapatnam, Andhra Pradesh, India. Her research interests are fault diagnosis and Structural Health Monitoring



Dr Ratnam Ch received his PhD from the Indian Institute of Technology, Madras, India, in 1993. In 1985, he joined Andhra University College of Engineering (AUCE), Andhra University, AP, India, as Assistant Professor in the Department of Mechanical Engineering, where he is currently the Professor and H.O.D. His research interests include structural health monitoring, vibration analysis and reliability and optimisation techniques.



Vana Vital Rao received his ME degree from Birla Institute of Technology, Mesra, Ranchi, India. He joined Visakhapatnam Steel Plant (RINL), Visakhapatnam, AP, India as a Management Trainee (Technical) in 1998 and is currently working as a Deputy General Manager in the Engineering Shops Department, Central Machine Shop, Visakhapatnam Steel Plant, AP, India. His research interests are fault diagnosis and condition monitoring.