

# “GSM & GPS Based Vehicle Theft Control System”

Miss. S.S. Kanase<sup>1</sup>, Miss. S.A. Yadav<sup>2</sup>, Mr. S.B. Jadhav<sup>3</sup>, Prof. M.M. Kadam<sup>4</sup>

<sup>1,2,3</sup> Students Department of Electronics and Telecommunication, DACOE, Karad

<sup>4</sup> Professor Department of Electronics and Telecommunication, DACOE, Karad

\*\*\*

**Abstract** - Currently almost of the populace having an own fomite , larceny is happening from anywhere where public green the vehicle .The safe of fomite is extremely essential for public vehicles. Fomite trail ing and locking organisation of rules installed in the vehicle, to track the place and locking engine motor . The exact location of vehicle identified using Global Positioning organisation (GPS) and Global system mobile communication (GSM). This organisation continously track location of theft vehicle and report the status to user.GSM send sms to arduino board.Respected person need to send password to controller to restart the vehicle and outdoors the door. This system is more secured, reliable and low monetary value .

**Keywords-** GPS modem, GSM modem, Arduino board, Transistor, Buzzer

## 1.INTRODUCTION

Various technologies have been introduced in recent years to detect car theft. For example, immobilizer to remotely disable the lost vehicle, microdot identification to identify auto parts using unique microdots, Electronic Vehicle Identification (EVI) to identify the vehicle against the registration database, lojack system to use in-built transponders to tracking down vehicle, GPS to location the position of lost vehicle by using global positioning system and so on. In this project we are going to track the vehicle by using GPS –GSM modem. The engine whose ignition disabled through the relay fed from the Arduino which gets command from the GSM modem. In this system we are going to use Arduino board which is an open source platform used for building electronic project. We also used GSM and GPS for tracking the location of vehicle. LCD display used for display values of latitude and longitude of vehicle location. Buzzer is used to detect the vehicle by using sound of buzzer.

## Literature Survey

Rear time tracking and locking of vehicles has been done from many researches and lot of work done for tracking the vehicle. Now a day various anti-theft modules like steering wheel locked equipment, network tracking system and electronic buzzer are developed.

A vehicle tracking system is electronic device, installed in vehicle to detect owner or to track the position of vehicle. This paper is proposed to design vehicle tracking system the can be done by GPS and GSM. This system is based on

Arduino board where tracking s done by Global System for mobile communication and position by Global Positioning System. These systems continuously watch vehicle and report status of Vehicle on demand.

## 2. BLOCK DIAGRAM

Arduino based vehicle tracking and controlling using GPS and GSM has following blocks.

- ARDUINO Board
- LCD display
- Transistor as a switch
- Buzzer
- Power supply
- GSM Modem
- GPS Modem

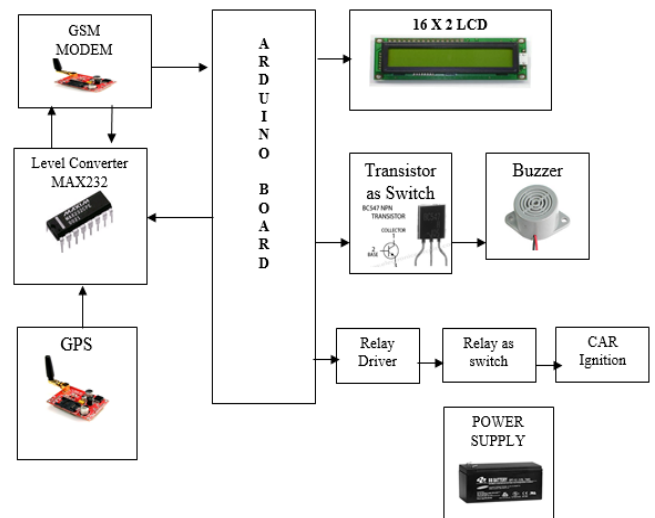

Fig.1:Block Diagram

## 3. HARDWARE COMPONENT

### 3.1. Arduino Board

Arduino is an open-source platform used for building electronics projects. Arduino consists of both a physical programmable circuit board and a piece of software, or IDE (Integrated Development Environment) that runs on your computer, used to write and upload computer code to the physical board. The Arduino platform has become quite popular with people just starting out with electronics and for good reason. Unlike most previous programmable

circuit boards Arduino does not need a separate piece of hardware (called a programmer) for loading new code onto the board – you can simply use a USB cable. Additionally, the Arduino IDE uses a simplified version of C++, making it easier to learn to program. Finally, Arduino provides a standard form factor that breaks out the functions of the micro-controller into a more accessible package.

The Arduino hardware and software was designed for artists, designers, hobbyists, hackers, newbie’s, and anyone interested in creating interactive objects or environments. Arduino can interact with buttons, LEDs, motors, speakers, GPS units, cameras, the internet, and even smart-phone or TV. This flexibility combined with the fact that the Arduino software is free, the hardware boards are pretty cheap, and both the software and hardware are easy to learn has led to a large community of users who have contributed code and released instructions for a huge variety of Arduino-based projects.

### 3.2. GSM Modem

A GSM modem is a wireless modem that works with a GSM wireless network. A wireless modem behaves like a dial-up modem. The main difference between them is that a dial-up modem sends and receives data through a fixed telephone line while a wireless modem sends and receives data through radio waves. Like a GSM mobile phone, a GSM modem requires a SIM card from a wireless carrier in order to operate.

A GSM modem can be an external unit or a PCMCIA card (also called PC Card). An external GSM modem is connected to a PC through a serial cable, a USB cable, Bluetooth or Infrared. Like a GSM mobile phone, a GSM modem requires a SIM card from a wireless carrier in order to operate.

PC's use AT commands to control a GSM modems. You can use a GSM modem just like a Hayes compatible modem. GSM modems support an extended set of AT commands. These extended AT commands are defined in the GSM standards.

So signal conditioning will convert its output in to Logic Zero and Logic One. It has OPAMP as comparator.

### 3.3. GPS Modem

Each GPS satellite transmits radio signals that enable the GPS receivers in your vehicle to estimate the satellite’s location, as well as the distance between it and your vehicles. The receivers then use these measurements to calculate where your vehicles are located on Earth and convert the calculations into geodetic latitude and longitude. A receiver needs signals from three GPS satellites to pinpoint your vehicle’s position

## 4. Result

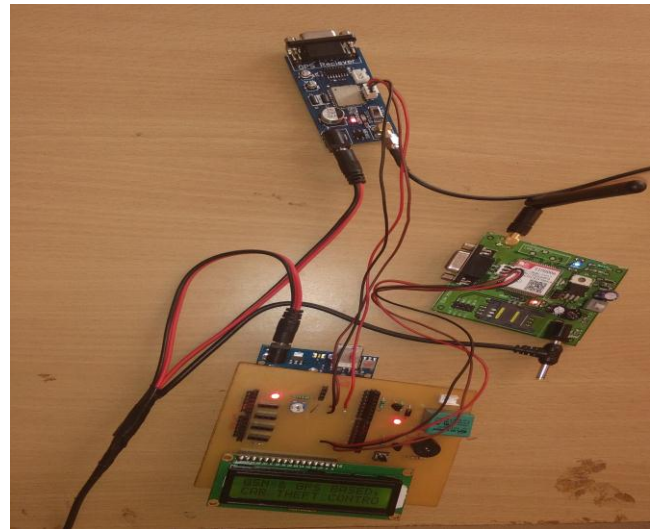

**Fig. 2 Project system**

### Result Flow

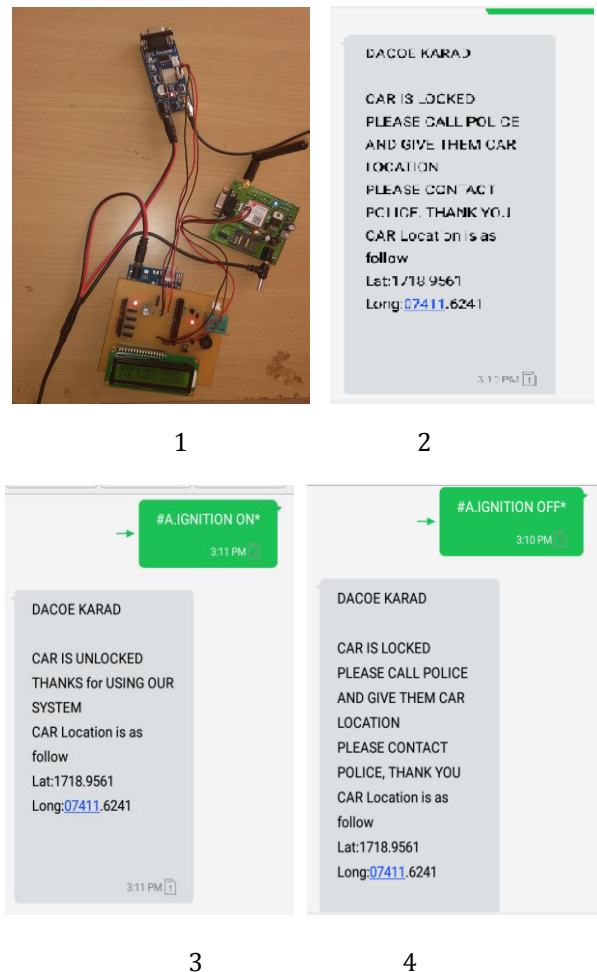

1

2

3

4

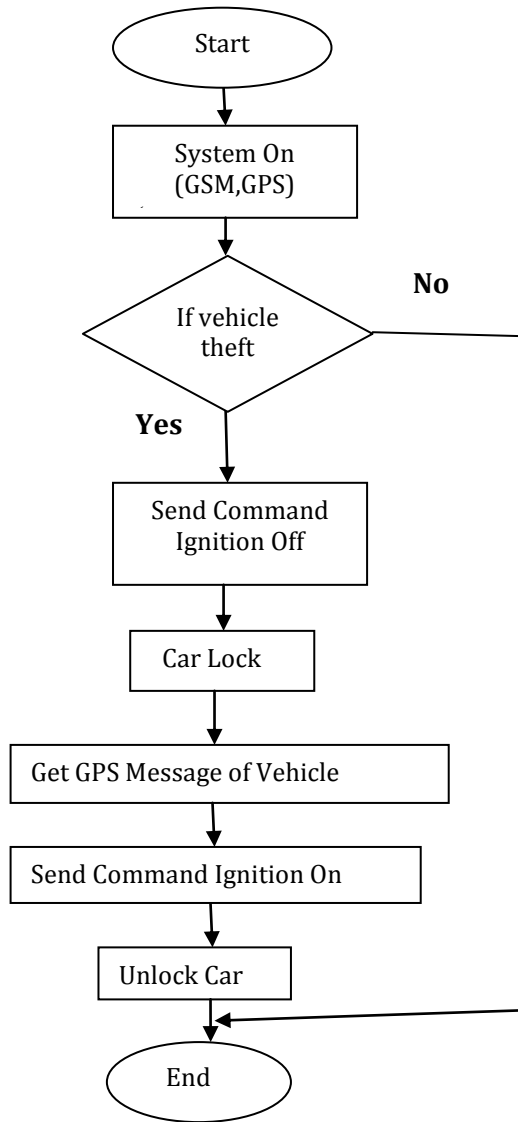

[3] Kunal Maurya , Mandeep Singh, Neelu Jain, “Real Time Vehicle Tracking System using GSM and GPS Technology- An Anti-theft Tracking System,” International Journal of Electronics and Computer Science Engineering. ISSN 2277-1956/V1N3-1103-1107.

[4] Abid khan,Ravi Mishra, “GPS-GSM Based Tracking System” International Journal of Engineering Trends and Technology- Volume3Issue2- 2012

### 5. Conclusion

In our project when we send the SMS “TRACK VEHICLE”, The SMS is received by vehicle and it will send SMS about their position. GPS is used for getting information about where our vehicle will present.GSM used for giving commands to arduino.and we can track the vehicle and monitor on it.Our project is very useful to track the stolen vehicles.

### 6. References

- [1] Pankaj Verma A1 J. S. Bhatia A2, “Design and development of GPS-GSM based tracking system with google map based monitoring”, International Journal of computer Science, Engineering and Application(IJCSEA) Vol. 3,No.3 June 2013
- [2] R. Ramani A1, S.ValarmathyA2, Dr. N.Suthanthira Vanitha “Vehicle tracking and locking system based on GSM and GPS”, International journal of intelligent system and applications, 2013, 09, 86-93[August 2013]