

# ADVANCED GUIDING TOOL FOR THE SELECTION OF CROPS

#1T.Shanmuga Priya, #2K.Sherin Banu, #3J.Sonaa, #4P.Bini Palas

#1,2,3 B.E -ECE Department, Easwari Engineering College

#4 Assistant Professor, ECE Department, Easwari Engineering College

\*\*\*

**Abstract** - Agriculture monitoring system and selection of crops has been facilitated by the recent developments in information technologies. Agriculture plays an important role in improving the economy and the employment opportunities in India. Mostly farmers face difficulties in the selection of crops. This can be overcome by using precision agriculture techniques that uses research data of soil characteristics, soil types, crop yield data collection and gives farmer the best suggestion in selecting the crops.

**Keyword** -DHT11 sensor, Moisture sensor, Node MCU,ESP8266 Wi-Fi Module, Motor driver, IoT(Internet of Things), DC fan, Cloud(Thingspeak)

## 1. INTRODUCTION

The world is witnessing fluctuations in terms of agricultural and farming land, this increases the demand of farming agricultural cooperatives that ensure high supply of agricultural goods. India has been one of the most productive countries when it comes to agricultural products India. Rural India has shown a significance and steady increase in farming development to produce comparatively higher amount to meet the demand of rising nation. Precision agriculture (PA), satellite farming or site specific crop management (SSCM) is a farming management concept based on observing, measuring and responding to inter and intra-field variability in crops. The goal of precision agriculture research is to define a Decision Support System (DSS) for whole farm management with the goal of optimizing returns on inputs while preserving resources. The most advantage of modern engineering techniques is to facilitate the agriculture by the good use of soil, climate and biological potential of fields to provide favorable condition for the plant to grow so as to increase the yield in specific region. The initial step of this method is monitoring the farming environment periodically. There are many agriculture monitoring system which includes data acquisition, transmission and managing the data. Sensors are used for providing data acquisition. There are separate sensors used for monitoring the moisture, temperature and other environmental conditions and the data are sent to the users through wireless data communication. Remote sensors are used to self-organize and to send data stably

and periodically to the control centre. These monitoring systems are mostly based on bus via cables. Through these parameters in several periods, they found that the plant growth was mainly depend on the change of climate in the farmland. The main aim of this work is to introduce the wireless sensor network in agriculture.

## 2. HARDWARE DESIGN OF SENSOR NODE

The hardware design of sensor nodes plays an important role in the wireless sensor networks. The sensor node mainly comprises of four parts such as sensor node module, Processing module, wireless communication module and the power module. The sensor module collects data regarding the temperature, humidity, light intensity and other parameters. The processor module mainly comprises of operations that controls ,stores and processes the collected data. Through this data we can receive the wireless applications on agriculture.

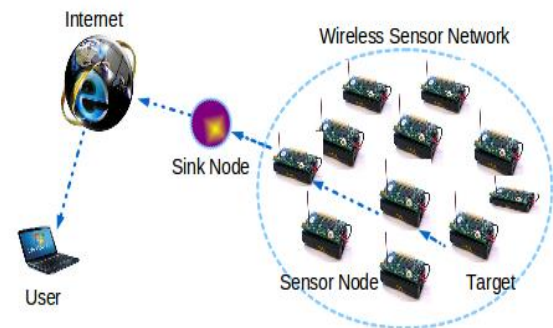

The wireless sensor network comprises of temperature sensors ,moisture sensors and humidity sensors which monitors the plant growth periodically and sends data to the process module which in turn stores, processes the acquired data .These data are in turn stored over the cloud which can be accessed by the user by using the wireless communication devices such as laptops, mobile phones etc.,

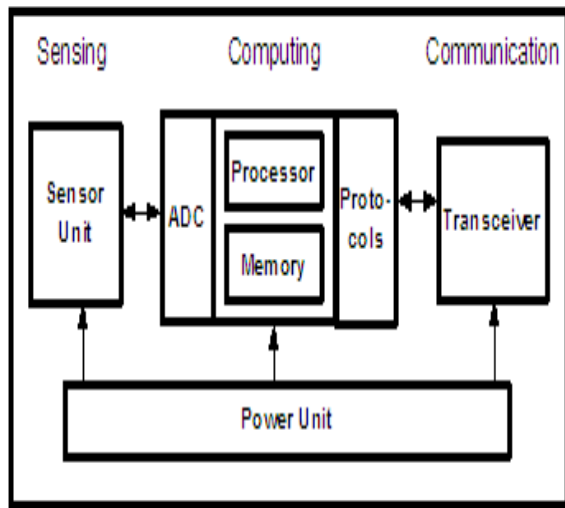

This block diagram shows us the detailed description of data acquisition and storage. The main components used here are Node MCU microcontroller unit to which the moisture sensors, temperature sensors are connected. The microcontroller unit is already programmed using c++,python language.

Microcontrollers perform the main task in the sensor nodes i.e. processing the data and controlling the functions of the other components. These are some of the controllers using as Digital Signal Processors, Field Programmable Gate Array and applications. So microcontrollers are more suitable for sensor nodes. The best choice for embedded systems is to use microcontrollers because of the services providing by them. A **sensor** is a device that detects and responds to some type of input from the physical environment. The specific input could be light, heat, motion, moisture, pressure, or any one of a great number of other environmental phenomena. The output of the sensing unit is sent to the computing unit. The computing unit comprises of analog to digital converter, processor, memory and protocols which aids in processing the data. These data can be accessed by the farmer anytime by using the wireless communication devices such as mobile phone, laptops, etc.,

### 3. RELATED WORKS

Agriculture monitoring system is mainly based on wireless sensor network which are driven by different applications and background operations.

In this agriculture monitoring system the sensor nodes connected to the microcontroller unit. These sensor network are used to sense the environmental conditions. This agricultural monitoring server system collects information about soil and other environmental parameters on the outdoors through WSN-based environmental and soil sensors, collects image information through CCTVs, and collects location information using GPS modules. This received information is processed and the database is prepared through the agricultural environment monitoring server consisting of a sensor manager, to collect information from the WSN sensors, an image information manager to manage image information collected from CCTVs, and a GPS manager, which processes location information of the agricultural environment monitoring system. To this agriculture monitoring system, a solar cell-based power supply is added for the server system to use in agricultural environments with insufficient power condition. This agricultural monitoring server system also monitor the environmental information on the outdoors periodically, which aids in increasing crop yields and improving quality in the agricultural field by supporting the decision making of crop producers through analysis of the collected information.

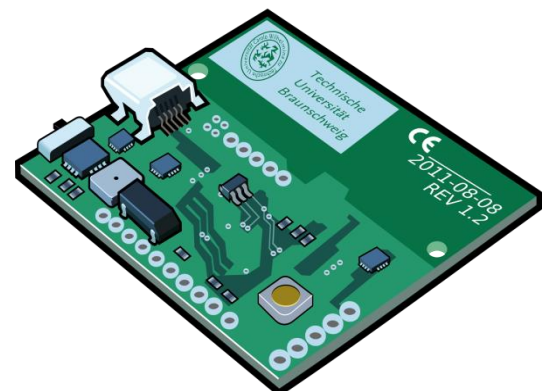

To find the accurate parameters across the farmland intel has undergone new project to measure temperature with dense deployment of 65 sensors in the farmland. Both work implemented the suggested and fixed routings to the network on specific farmland. In this monitoring technique they used Bluetooth which is one of the most robustness wireless communication for short range purpose. This system suggested a Bluetooth RS-232 serial adaptor with communication range of 1200m. In this method five infield sensing transmitters sends the data to the base station for a distance of 700m Bluetooth technologies. In this the sensor nodes are interconnected via IEEE802.15.4. It consists of Gateway notes which is about 5.2 and 8.7 km from the central station. The gateway mote communicate with the mobile networks and remote centers can route the gateway mote with protocols such as TCP/IP protocol. The previous monitoring system inspire us to do agriculture based on WSNs.

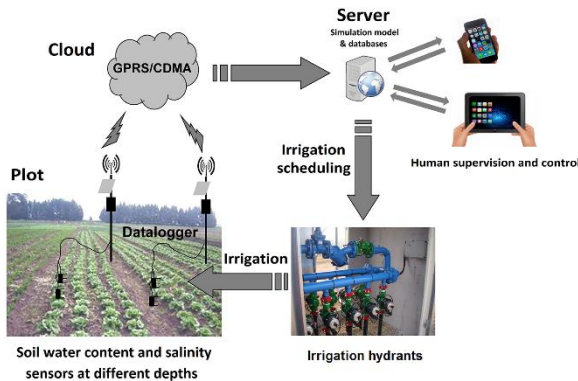

In this monitoring system the sensor nodes which are connected to the microcontroller unit is already programmed which consists of the reference values. When these recorded data exceeds the reference value the external set up is driven automatically which brings the data to normal value. By using this technique we can monitor the agriculture system automatically without any labors. The external setup includes the water pump ,fan ,etc., to bring the temperature and moisture level to the normal value when they exceeds the given reference value. This system has the main disadvantage that the data get through sensing are not stored over the cloud for the future reference which aids in the selection of crops. Thus it can only monitor the plant growth but do not aid in the selection of crops.

#### 4. PROPOSED SYSTEM

The ecological and geographical data are more important for the selection of crops. To track these data ,sensors are connected to the Node MCU .The MCU unit is already programmed which consists of data sheet to compare with

the sensed values. This system is an enhancement of agriculture monitoring system which performs both monitoring and data acquisition. The monitoring system monitors the plant growth periodically and the external set up is driven which brings the recorded data to the normal value. In addition to this it pushes the recorded value over the cloud from which the data can be retrieved anytime using wireless devices such as mobile phone,laptop,etc.,These data contains the information at the periodic intervals. From these value we can get the data for the favorable condition for the plant to grow.



The external set up consists of motor driver which in turn drive the motor and the dc fan with reference to the normal value. The precision agriculture technologies are beyond the reach of most smallholder farmers, but several technological innovations have created scope for providing tailored information to farmers . New measurement technologies that enable better learning about the agriculture to the farmers. Today's world is a place of uneven development, unsustainable use of natural resources, worsening impact of climate change, and continued poverty and malnutrition. Poor food quality and diets are partly responsible for the increase of chronic source of causing damages to the organ system. diseases like obesity and heart disease. Agriculture is closely linked to these concerns, including the loss of biodiversity, global warming and water availability. So we are in need to practice agriculture without using any pesticides and fertilizers which are the main source of causing disease to the organ system.

This makes the agricultural practices easy and also avoid damages to the crops. The main aim of this system is to enhance the organic farming. By using this method we can grow the crops without using any pesticides. This is because we tend to use pesticides only when there is any fungal growth. By properly monitoring the water level ,temperature we can avoid any fungal or bacterial growth in the plant. Through this system we can assure the quality of plant growth in an organic manner. This is suitable for

any kind of crops. Through this we can do farming even in a small area without any loss. The main motto of this system is to provide the favorable condition for the plant growth in a natural way. By using this method we can bring back our traditional agriculture strategy in a modern way. It also assist the person who is new to farming by providing information about the suitable plant for the present environmental conditions. By knowing these details we can also artificially create the best environment for the plant growth. PAD is a non-profit organization with a mission to support smallholder farmers in developing countries by providing customized information and services that increase productivity, profitability, and environmental sustainability. It is an ecofriendly system which avoids the usage of pesticides and insecticides. By following this method we can avoid damages to crop by planting the suitable crop according to the climatic conditions ,temperature and moisture level. We have different sensors to detect the environmental parameters. The digital humidity and temperature sensor and moisture sensors are present which give information about the environmental conditions periodically. In today's world to meet the increasing demand in the food industry the farmers tend to use more pesticides to make the plant growth fast and to increase the yield. This method is to enhance the plant growth in natural way.

### 5. DHT 11 SENSOR

DHT11 is a Humidity and Temperature Sensor, which generates calibrated digital output. DHT11 can be interface with any microcontroller like Arduino, Raspberry Pi, etc. and get instantaneous results. DHT11 is a low cost humidity and temperature sensor which provides high reliability and long term stability. By connecting the DHT11 sensor to the plant we can get the information about the plant's humidity and the temperature conditions.

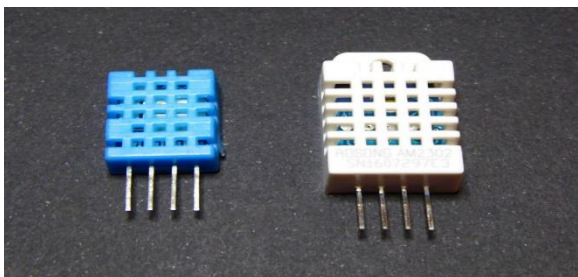

Power supply: DC 3.5~5.5V. Supply Current: measurement 0.3mA standby 60μ A. Sampling period: more than 2 seconds.

**Pin Description.** 1, the VDD power supply 3.5~5.5V DC. 2 DATA serial data, a single bus. 3, empty pin. 4, GND ground, the negative. Thus it can be connected to the microcontroller unit. The MCU is already programmed which contains the reference value of the humidity.

### 6. MOISTURE SENSOR

Soil moisture sensors measure the volumetric water content indirectly by using some other property of the soil, such as electrical resistance, dielectric constant, or interaction with neutrons, as a proxy for the moisture content. The relation between the measured property and soil moisture must be calibrated and may vary depending on environmental factors such as soil type, temperature, or electric conductivity. Reflected microwave radiation is affected by the soil moisture and is used for remote sensing in hydrology and agriculture. Portable probe instruments can be used by farmers or gardeners. This moisture sensor in turn is connected with the microcontroller unit which consists of reference values. By comparing these data with the reference value the external water motor is driven so as to increase or lower the moisture level.

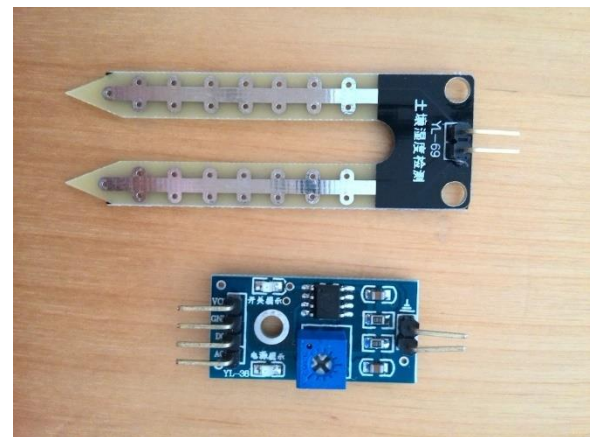

## 7. NODE MCU

NodeMCU is an open source IoT platform. It includes firmware which runs on the ESP8266 Wi-Fi SoC from Espressif Systems, and hardware which is based on the ESP-12 module. The term "NodeMCU" by default refers to the firmware rather than the development kit. The firmware uses the Lua scripting language. This is the processing unit which processes and analyses the received data and pushes it into the cloud. The microcontroller unit is programmed internally from which the collected data are pushed into the cloud which can be accessed anytime for the future reference.

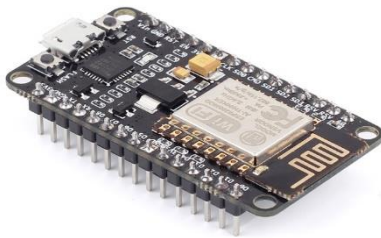

It is a development kit which has vast applications. In agriculture monitoring and data acquisition system the Node MCU is used for processing the data.

## SIMULATION AND EXPERIMENT

The parametric condition which are detected by the sensors connected to the Node MCU unit is already programmed using the c,c++ or python language. The collected data are in turn pushed into the cloud which can be accessed anytime using wireless devices such as mobile phone. Thus the favourable condition for the plant growth can be known to the farmers in prior to planting which increases the yield and prevents any damage to the crops.

## CONCLUSION

In contrary to conventional agriculture monitoring system which only depends on the analog monitoring machines, our proposed system is implemented not only to monitor the environmental condition wirelessly but also to access data anytime by pushing the collected data over the cloud which aids in the selection of crops. This method is to increase the agricultural productivity without using any fertilizers or pesticides. This method is very useful in providing data to the farmers and also plays an important role in organic farming. Detection of moisture level helps in avoiding the use of pesticides. This is because when there is a variation in the moisture from the normal value then it creates a suitable condition for the fungal or the

bacterial growth. So, by monitoring the plant growth periodically if there is any variation in the data we can drive the external set up to bring the value to the normal level. Thus through this method we can enhance the organic farming.

Data acquisition is the main advantage of this proposed system. This is because it enables the farmers to get information about the plant growth under the particular environmental condition in prior which helps in increasing the yield and provide us healthy fruits and vegetables without any pesticides or fertilizers. It also helps the person to do farming who is new to agriculture. This system is a guide to agriculture which promotes organic farming. In today's world everything which we eat that includes fruits ,vegetables contains chemicals in form of pesticides. This increases the disease rate to higher level. In olden days they followed traditional agriculture methods, that is it takes long time to grow the crops. In order to meet the rising demands today we use chemicals to enhance the plant growth. The crop which takes about 6 months to grow can be now grown at 3 months by using different chemicals. Because of this we easily get affected by diabetic, blood pressure, cancer and many dreadful diseases. Thus to avoid the use of pesticides which is the main factor in causing the dreadful diseases.

## REFERENCES

- Richard Beckwith, Daniel Teibel and Pat Bowen. Report from the Field :Results from an Agricultural Wireless Sensor Network.In First IEEEWorkshop on Embedded Networked Sensors, 2004.
- Rajalakshmi.P, Mrs.S.Devi Mahalakshmi“*IOT Based Crop-Field Monitoring And Irrigation Automation*” 10th International conference on Intelligent systems and control (ISCO), 7-8 Jan 2016 published in IEEE Xplore Nov 2016.
- Tanmay Baranwal, Nitika , Pushpendra Kumar Pateriya “*Development of IoT based Smart Security and Monitoring Devices for Agriculture*” 6th International Conference - Cloud System and Big Data Engineering, 978-1-4673-8203-8/16, 2016 IEEE.
- Nelson Sales, Artur Arsenio, “*Wireless Sensor and Actuator System for Smart Irrigation on the Cloud*” 978-1-5090-0366-2/15, 2nd World forum on Internet of Things (WF-IoT) Dec 2015, published in IEEE Xplore jan 2016.

- A. K. Fung, F. T. Ulaby. Scattering from a Vegetation Layer. IEEE Transactions on Geoscience Electronics, vol. 17, pp.1-6. [3] Samuel Madden, Michael Franklin, Joseph Hellerstein and Wei Hong TAG. A Tiny Aggregation Service for Ad-Hoc Sensor Networks. In 5th Symposium on Operat
- C. He, Y. Gong, and W. Lin, "Facility Agriculture Intelligent Monitoring System Based on Wireless Sensor Networks," Journal of Anhui Agricultural Sciences, vol. 38, pp. 4370-4372, 2010.