

COIN AND RFID BASED MOBILE CHARGING

Rishabh Srivastava¹, Satyam Gupta², Shyam Chaudhary³

^{1,2,3} Electronics and Communication, IMS Engineering College, Adhyatmik Nagar Ghaziabad

Abstract – The coin-based mobile charger designed in this paper is providing a unique service to the rural public area. Where grid power is not available for partial/full daytime so we use coin based mobile charger using radio frequency identification and a source of revenue is provided. The coin-based mobile battery charger can be quickly and easily installed outside any business purpose. The mobile phone market is a vast industry, and has spread into rural areas, public places and railways etc. as a essential means of communication. While the urban people use more complex mobiles with good power batteries lasting for several days, the rural people buy the mobile phones that require charging instantly. So many times battery becomes dead in the middle of conversation particularly at inconvenient times when access to a standard charger is not possible, so we use this coin-based mobile battery chargers are made to solve this huge problem. The user has to plug the mobile phone into one of the adapters and insert a coin or RFID reader then phone will then be given a power for charging. The capacity of mobile charging is developed with the help of fixed values. It is, of course, possible to continue charging the mobile by inserting more coins or RFID reader.

INTRODUCTION

Today mobile phones have a very important value, as well as mobile phone has become a great communication media for public use and industry use. This system that is coin based mobile charger give the charging to mobile phone. Many times battery becomes dead while conversation particularly at in emergency times when access to a standard charger isn't possible. The coin-based mobile battery chargers are developed to solve this problem. This system is like coin based cell phones which was famous in beginning of 20'th century. Initially when we are inserting the coin into coin insertion slot then cell phone will be charged, it will compare the image of coin which is stored in the database. If the new image and stored image is matched then it will show on the display. Then we can connect our mobile to the charging plug and charging will start. Charging is depend on the coin with the help of fixed value. Accordingly coin charging will increase means if we insert 1Rs coin then it will charge up to some time. In this system we use the 1 Rs coin or RFID card.

BLOCK DIAGRAM

The block diagram has the three stages,

- Input stage
- Middle stage
- Output stages

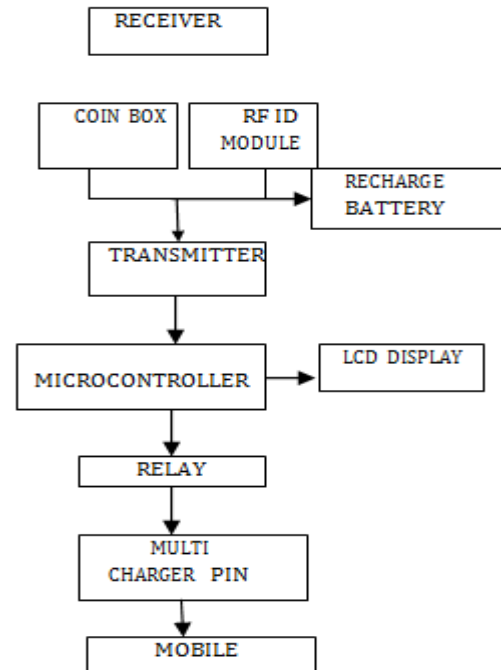

Fig 1. Block diagram of coin based mobile charger

INPUT STAGE

The input stage is the primary step of this stage. The coin is to be inserted in a coin box and then the work of a transmitter and receiver is taken place. The RFID is also used for the people who not have a coin and can also requires for long time period of charging. RFID verification acquires it transmit and receives the signal .both the coin and RFID signals are send to the micro controller. The input stage is very crucial point due to using of sensor. Using coin and RFID card for charging of android cell phone . Where the grid power is not available, it stores the power and supply in inverter and solar panel whenever it necessary battery charge draw the power to the supply. Whenever we are putting coin and RFID reader then LCD display is start.





Fig 2. Coin and RFID card inserting setup

MIDDLE STAGE

Microcontroller is the middle stage. Microcontroller works when the command will receive from .RFID (or) coin box. So LCD display shows all the process of controller and inserted of coin or RFID card swaps. Middle stage is the main working process stage. Using micro controller in the middle stage.

Output Stage

The output stage is the stage on which charging of mobile is complete. The power supply from the relay is given to the mobile charger by pin. By connecting the mobile phone to the mobile charger pin the number of coin insertion (or)RFID card read according to these amount the completion of charge is taken placed.

CHARGER

Mobile phone chargers are nothing but AC to DC converters using transformer in adopter. They take an input of 220 volt AC and give an output voltage around 5volt DC. Generally the output voltage of the charger is in the range of 5 to 5.5 volts DC.The flow of current in the cell phone for charging is between 1 amp to 2 amp.Multiple charger pin is used according to the cellphone.



Fig 3. Multi charger Pins Used For Mobiles

RELAY

In the charger Relay are used as a switch..

Power supply

It is main component of the circuit. Power supply is provided to microcontroller and other device by AC or DC adapter.

Microcontroller

In coin based charging basically we use PIC 16F 877A microcontroller is used. IC 16F877x is used.

ALGORITHM

- 1) Start
- 2) Insertion of coin
- 3) Collect the coin
- 4) Swap RFID card reder
- 5) Command to the microcontroller
- 6) Battery charging
- 7) Power supply to the mobile charger pin
- 8) Mobile charging will ready to work
- 9) Charging will displayed on LCD screen.



Fig 4. Experimental Setup

FUTURE CONSIDERATION

This idea can be used for many purposes instead for charging the mobile. It used for buying foods in the restaurant, snacks in the stores, by inserting the required amount of money to that particular product. The tickets buying in the trains, buses in the fast moving society by this idea the reduction of queue in the public places



Fig 5. Mobile Charging Setup

[4] M. A. Usta, O Akyazi and I. H Altas “ Design And Performance Of Logic Controller”, 6th Advanced Technologies Symposium.

[5] International Journal Of Recent Research in Electrical And Electronics Engineering (IJRREEE) Vol.3. issue1 pp;(1-4), Month January – March 2016.

ADVANTAGE

Simple and hand efficient
 Less cost
 Reduced man power
 Low power consumption

APPLICATION

Industrial purpose
 Power management systems

The coin based mobile phone charger is very useful for public for using coin to charge for the mobile phone in any places at any time.

CONCLUSION

A method of charging mobile batteries of different manufactures has been designed and developed whenever required. This project is very important and useful in life. Because now days the necessity of communication is very important, so every person having cell phone but every time we cannot carry charger with us. When we are going for long tour we may always forget to carry phone charger. This project is very helpful in helping the people by coin based charger. Also now days because use of internet and smart phones, this kind of project is very useful for life. Conventional grid power is used for mobile charging hence project is very low cost.

REFERENCES

- [1] S.B Shridevi, A.Sai Sunnel, KNalini “ Coin based and RFID,”IJAREC, pp 741-741, Sept 2016.
- [2] K M Trautz P P Jenkins, R. J. Walters, D. Scheiman, R. Hoheisel, R. tatavarti, R. Chan, H. Miyamoto, J.G.
- [3] S.Banu Pratap, R. Priyanka, G.Gunnu, Dr.Sujatha, Coin Based Cell Phone Charger, International Journal Of Reserch And Technology Issue3, March-2013