

Design and Analysis of Hybrid Lap Joint using Clinging Tintur- Review

Mr. Somesh.P.Patil¹, Prof.C.R.Patil², Prof.Tushar Hingwe³

¹ M.E. 2nd Year Student, Department of ME CAD/CAM, Padm. Dr. V. B. Kolte College Of Engineering, Malkapur, Maharashtra, INDIA

² Professor, Department of Mechanical Engineering, P.R.M.I.T&R College, Badnera, Maharashtra, INDIA

³ Assistant Professor, Department of Mechanical Engineering, .Dr. V. B. Kolte College Of Engineering, Malkapur, Maharashtra, INDIA

Abstract - This paper dealing with investigations of adhesive layer characteristics and it is a part of our continuous research on adhesively bonded joints. Previous experimental analysis has shown that bonding of different adherend materials using the same adhesive leads to the different behavior of adhesive. This effect is more evident in numerical modeling of adhesively bonded joints, especially in bonding of adherends of higher yield strength. To understand how adhesives work, it is necessary to understand their mechanical properties and the chemistry used to create those properties. The object of present investigation is therefore to research cohesive and adhesive characteristics of chosen structural adhesives in correlation with adherend materials to be bonded. In particular, two- component structural epoxy adhesive and aluminum as adherend material have been tested.

Key Words: Adhesive, Single lap joints, Finite element, UTM, 3D model using CATIA, ANSYS, etc.

1. INTRODUCTION

Adhesive-bonding is often used in multi-component structures, since it provides several advantages over welding, riveting and bolting methods, such as reduction of stress concentrations, reduced weight penalty and easy manufacturing. Commercial structural adhesives range from strong and brittle to less strong and ductile. A new family of polyurethane adhesives combines high strength with large ductility. The main parameters affecting the joints' strength are L O , adherend material (i.e., Young's modulus, E) and thickness, and adhesive thickness (t A) and properties (mainly strength and ductility). The effect of L O depends on the type of adhesive (i.e. ductile or brittle) and on the type of adherend . For bonded joints with elastic adherends and ductile adhesives, the strength is roughly proportional to L O . For joints with elastic adherends and brittle adhesives, the joint strength is not proportional to the overlap and a limit strength is attained, because the adhesive does not accommodate peak stresses and failure is ruled by these peaks. In joints with yielding adherends, failure is ruled by the adherend yielding and again a steady-state value is attained in the maximum load (P m) vs. L O plot. The adherend properties (stiffness, strength and ductility) also have a large effect on the joints' strength. The higher the adherend stiffness is, the smaller are the strains at the

overlap edges, and lower will become the effect of the differential straining in the adhesive, i.e., the shear stress distribution becomes more flat. Excessive adherend yielding at the bonding edges can trigger premature joint failure because large plastic strains appear at these regions. The effect of t A on single- lap joints is well documented. Most of the results are for epoxy adhesives and show that the lap joint strength decreases with the increase of t A. The adhesive properties have a high influence on the joint strength, but a stronger adhesive does not necessarily give a higher joint strength. A high strength but brittle adhesive achieve locally high stresses in the overlap corners, but does not allow stress redistributions to the low stressed areas. As a result, the average shear stress at failure is very low. On the other hand, adhesives with high ductility and low modulus have generally a low strength. However, they distribute the stresses more uniformly along the bond line and deform plastically, which turns the joints stronger than with strong but brittle adhesives.

Currently, a large number of predictive techniques is available for bonded joints, either analytical or numerical. Extensive reviews of these methods are provided by da Silva et al. for analytical methods and He for Finite Element-based techniques. Analytical methods are easy to use, but they usually consider simplification assumptions . For complex geometries and elaborate material models, a Finite Element analysis is preferable to obtain the stress distributions. Fracture mechanics-based methods use the fracture toughness of materials as the leading parameter for fracture assessment. More recently, powerful numerical techniques such as CZM became available, which predict the structures' strength by combining stress criteria to account for damage initiation with energetic, e.g. fracture toughness, data to estimate crack propagation . This technique is particularly attractive for bonded joints, since the ductility plays a major role in the failure process because of the stress gradients. However, the method relies on an accurate measurement of the cohesive strengths in tension and shear (t_{n0} and t_{s0} , respectively), and of the tensile (G_{IC}) and shear toughness (G_{IIC}) . CZM accurately predicts the strength of bonded joints if the fracture laws are estimated correctly. Ridha et al. studied by CZM adhesively-bonded scarf repairs on composite panels bonded with a ductile epoxy adhesive. Softening laws with linear, exponential and trapezoidal shapes were compared. The predictions were very accurate,

although the linear and exponential models resulted in under predictions of the repairs strength of nearly 20%, on account of excessive plastic degradation at the bond edges that was not observed in the real joints. In this work, the performance of a brittle (Araldite ® AV138), a moderately ductile (Araldite ® 2015) and a largely ductile adhesive (Sikaforce ® 7888) was tested in single-lap joints between aluminium adherends with varying values of L O . The experimental work carried out is accompanied by a detailed analysis by Finite Elements, starting with the plot of elastic stress distributions, and strength prediction based on CZM. This procedure enabled assessing in detail the performance of the predictive technique applied to bonded joints. Moreover, it was possible to evaluate which family of adhesives is more suited for each joint geometry.

1.1 AIMAND SCOPE OF THE WORK:

Objective of this Lap joint adhesive test is to demonstrate the different behaviors of adhesives during and after Tensile/Bending test. Peak load and extension parameters are going to be recorded to determine max force and elongation of different adhesives conditions on the Lap joint. To measure thickness of adhesive bond and curing temperature of lap joint.

1.2 LITERATURE SURVEY

[A] Hsu Hnin Wai , Dr. Ehab Hamed Summery-

Adhesive bonding is a process of joining materials by placing an adhesive bond between two surfaces called adherend. The application of lap-joints in load-bearing structure has become more widely implemented in various engineering industries such as aerospace, automotive, electronics, wood and plastic industries and in civil engineering. The advantages of lap-joint include its lightweight, low cost, ease of application and improved mechanical performance. However, there are ongoing studies on better prediction of stress distribution and failure criterion for long term safety of the structure. The purpose of the research is to understand the stress distribution of lapjoints under applied force made with steel and composite in order to provide a basis for predicting their debonding failure load. To proceed with experimental creep analysis of the debonding failure, it is important to verify the capability of the analysis method through comparing the simulation outcome with studies conducted previously. Through this understanding, the research will continue to non-linear stress distribution.

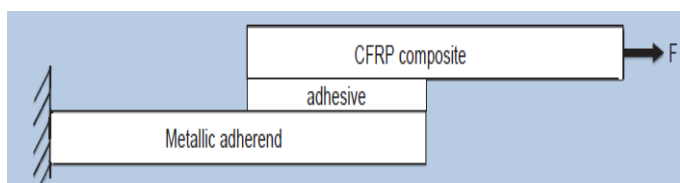

Conclusion-

- 1) ANSYS is capable of predicting the stresses distribution in the lap-joint
- 2) This can be further used to understand the non-linear adhesive failure of lap-joints made with different materials.

[B] Mrs. J. G. Nikarn', Prof. Satish S. Kadam:!

Summery-

Adhesively bonded joints are widely used in the aerospace and automotive industries. in various structural systems: evidence of interface failure. has been observed in many cases. The safety and reliability of these systems are dependent on the proper design of the constituent components. These components are often subjected to complex service loading conditions. However. the failure mechanism is not well understood and considerable effort has been devoted to testing, theoretical prediction. and numerical analysis to effectively address this issue. Adhesively bonded joints can provide an efficient method of joining that would be more extensively used if reliable methods of testing and analysis were available. In this paper. the focus i placed on methods of resting and analysis and the effects of ariaiions in the lap length. type of material be joined. Curing time and thickness of the adhesive bondline.

Conclusion-

The sum of squares due to various factors is a measure of the relative importance of the factors in changing the strength of lap joint. A primary goal in conducting a matrix experiment is to optimize the product or process design i.e. to determine the best or the optimum level for each factor. The optimum level for a factor is the level that gives the highest value of strength in the experimental region. Based on the matrix experiment. we can conclude that the settings A,B ,C,D2 would give the highest strength. Factor D. type of material makes the significant contribution of in the total results. Lap length (A3) and type of material (B d results in 5.29% and 39.14% participation respectively in the strength of the lap joint. Curing time (C1) and Adhesive thickness (D2) also share 31.47% and 21.42% in total strength.

From ANOY A it is observed that, there is 95% probability of factor A. and 99% probability of factor B, C and D to significantly influence the total result. The results must be within the range of, $x = 18.11 + 1.7018 N/mn/'$ to achieve a probability of 95o/c.

[C] A. Çalık1*

Summery-

In this work, the effect of adherend shape on the tensile strength of adhesively bonded single lap aluminum structures joint was numerically studied using three dimensional finite element models. Six joint models were

investigated. In this paper, a static finite element analysis was performed in ANSYS considering geometric nonlinearities. The results show that the adherend geometry has the highest effect on peel and shear stresses. Similarly, for rounded and/or tapered geometries, adhesive material properties also cause a higher percent reduction in stress concentration.

Conclusion-

Computational studies were carried out using finite element analyses in order to determine the effects of adherend shape geometry on the peel and shear stress state in adhesively bonded single lap joints. A few joints with different adherend shape configurations were regarded, which include outside taper (Model 1), outside rounded (Model 2), inside taper (Model 3), inside rounded (Model 4), recessing (Model 5), and rounded recessing (Model 6). A comparison to the simple single-lap joint (reference model) was made to make an observation of the percent reduction in stresses for each adherend geometry.

The effects of Young's modulus of adhesive and adherend shape geometry on stress distribution can be concluded as follows:

- 1) In Model 6, peak value of the peel stress concentration occurring on the free ends of adhesively bonded region is low compared to other models. Reduction of this stress is very effective in initiating damage and this decrease played a significant role in the increase of joint strength.
- 2) Decrease of Young's modulus of the adhesive leads to the lower peel stress, especially in the Model 6 compared to other joint models.
- 3) While the effect of adherend recessing on the peel stress reduction in adhesive single lap joint is greater than inside and/or outside tapered adherend geometry, the effect of inside tapered adherend geometry on the maximum shear stress reduction in adhesive single lap joint is greater than adherend recessing and/or outside tapered adherend geometry.
- 4) Effect of rounding the adherend corners on the stress reduction in bond region are significant especially in tapered adherend geometry compared to adherend recessing.

2. DESCRIPTION OF THE PROBLEM

In Lap Joint problems occurs the mostly in numerical research because mechanical properties of adhesive are unknown. Accuracy of adhesive properties data depend on reliable materials models that can be used to predict the strength of adhesively bonded structures. In particular, two-component structural epoxy adhesives Araldite and aluminium as adherend materials have been tested experimentally and numerically.

Different material of lap is used to joint with the adhesive epoxy Araldite. Thickness should be in proper condition, variation reduces in lap joint with the use of optimum process. Curing of lap required more time to come to in room temperature. Strength should be maintain for lap process of more maximum bonding of two different hybrid i.e. aluminium and MS steel joint should be maintain.

2.1 ADVANTAGES OF THE ADHESIVE JOINTS

- The mechanism of adhesion helps to reduce stress concentration found in bolted, riveted and welded joints.
- Shock and impact characteristics of the joints are improved
- Dissimilar materials, such as metals, plastics, wood, and ceramics can be joined.
- Adhesive joints allow sufficient mechanical compliance in parts subjected to thermal distortion.
 - Adhesives can be contoured and formed in various fabrication processes.

2.2 METHODOLOGY

1. Initially the whole study has been made regarding the sample preparation, curing temperature and araldite to be used.
2. The samples required two different types of the plates, one is of aluminium and second is steel. Aluminium plates were cut with the help of grinding wheel of rough grade. For the cutting of steel plates laser cut technology was used.
3. After the plates were cut according to the size, a finishing hand was given to the edges of the plates and they were made ready for further treatment.
4. Now a suitable Araldite AW4859/ Hardener HW4859 was selected as an adhesive bonding agent after making a study for the adhesives. Also its properties were studied from research paper.
5. After that the plates were selected for bonding and adhesive layer thicknesses of 20mm, 25mm and 30mm was selected from research paper.
6. First the steel plate was held on a table and adhesive layer was gently applied on it with random value of thickness.
7. Then the aluminium plate was placed on the steel plate where the adhesive layer was implemented. After that the plates were held in a C clamp and gradual tightening was done.
8. The C clamp was being tightened until the required layer of adhesive thickness was achieved. This was done by

first measuring the thickness of steel and aluminium plate and then adding the value of adhesive layer to it.

9. In this way all the nine samples were prepared and given the names A1 to A9 respectively.

10. Then the samples were backed in an Oven according to the temperatures mentioned in the table.

11. Now the test was conducted on the UTM machine. The gauge of 50mm was used to apply the force on the samples. The test was carried out to find the load vs. deflection curve and the value of force at which the bond failed.

2.3 MATERIALS FOR LAP JOINT

Adhesive materials

Different types of adhesives are epoxies; polyester resins, etc are mostly used to joint different specimen and laps. Some are explain below.

a) Araldite

ARALDITE® AW4859 is a component, epoxy adhesive paste of high strength and toughness. Performances can be enhanced by post-curing at elevated temperature. It has been designed to perfectly bond onto composites, especially CFRP but it is suitable for bonding a wide variety of metals, ceramics and many other substrates in common use.

The strength and durability of a bonded joint is dependent on proper treatment of the surfaces to be bonded. At the very least, joint surfaces should be cleaned with a good degreasing agent such as acetone, iso-propanol (for plastics) or other proprietary degreasing agents in order to remove all traces of oil, grease and dirt. Low grade alcohol, gasoline (petrol) or paint thinners should never be used.

The strongest and most durable joints are obtained by either mechanically abrading or chemically etching ("pickling") the degreased surfaces. Abrading should be followed by a second degreasing treatment.

b) Epoxy

Epoxy resins are known as polyepoxides are a class of reactive prepolymers and polymers which contain epoxide groups. Epoxy resins may reacted either with themselves through catalytic homopolymerisation and with a wide range of co-reactants including polyfunctional amines, acids and thiols. These co-reactants are often referred to as hardeners or curatives and the cross-linking reaction is commonly referred to as curing. Reaction of polyepoxides with themselves or with polyfunctional hardeners forms a thermosetting polymer, often with a favorable mechanical properties and high thermal and chemical resistance. Epoxy has a wide range of applications in metal coatings, high tension electrical insulators, fiber-reinforced plastic materials and structural adhesives.

3. Experimental Work of lap joint

Three parameters were selected for the experimentation such as: overlap length, bond line thickness and curing temperature. From the literature, we was observed that overlap length of 20 mm to 30 mm was optimum, whereas the bond line thickness ranging from 0.2 mm to 0.8 mm gives better joint strength . The technical data sheet available for Levitate/Araldite Standard adhesive depicts that cure temperature between 300C to 700C will give best suited joint strength.

Hence, variation in curing temperature selected was from 300C to 700C. Selected parameters were distributed with three levels as mentioned above and experiment is carried out.

4. Lap joint in CATIA

Based on the dimensions obtained from the conventional design of Lap joint, the model of the Lap joint was created with the help of 3-D modelling CAD software CATIA. Document of CATIA is made from individual elements similar to an assembly which is made from a number of individual parts. The elements of CATIA are called features. During document creation, a number of features such as charts, fillets, chamfers, holes, pockets and pads can be added.

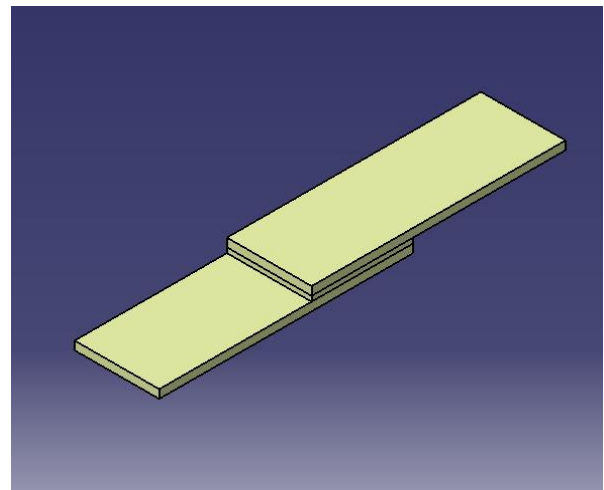

Fig.1:-Solid model of lap joint created in CATIA

REFERENCES

- [1] Hsu Hnin Wai , Dr. Ehab Hamed Simulation of Stress Distribution at a Single Lap-joint. International Journal of Adhesion and Adhesives 55 (2014): 1-11.
- [2] Mrs. J. G. Nikarn', Prof. Satish S. Kadam. Shear Strength Analysis of Adhesively Bonded Single Lap Joint using Taguchi Method.

[3] A. Çalik^{1*} Effect of adherent shape on stress concentration reduction of adhesively bounded single lap joint. Engineering Review, Vol. 36, Issue 1, 29-34, 2016.

[4] L. J. HART-SMITH Adhesive bonded single –Lap joints. NASA CR 112236.

[5] Mr. Gajanan M. Kulkarni¹, Prof. B. D. Gaikwad² Strength Analysis of Steel Adhesive Double Lap Joints Reinforced by Rivets using FEA & Experimentation. Vol.3 Issue 12, December 2015 Pgs: 1-11.