

Protection of Distribution Transformer By Using Variable Reluctance Method

Sharad Sampat Khade¹, Sidhaganesh Manmath Gote², Asst. Prof. R.M. Zende³

¹Bachelor of Electrical Eng. ZCOER, Pune

²Bachelor of Electrical Eng. ZCOER, Pune

³ Professor, Dept. of Electrical Engineering, Zeal college of Engineering and Research Narhe, Pune, Maharashtra, India

Abstract - : Distribution transformers are the widely installed and most commonly applied power device in transmission and distribution networks throughout the world of modern power systems. In this invention, the fault-current-limiting capability is enabled in power transformers by accepting the theory of virtual-air-gap (VAG) in electromagnetics. The concept of VAG is nothing but the saturate a certain portion of the magnetic core to change the reluctance of magnetic loops. VAG is not an actual air gap but a saturated portion of the magnetic core, which restricts the magnetic flux to follow through it. In distribution transformers, electric power is transferred between electric windings through the magnetic core interface. By changing the dc current, the redistribution of magnetic flux and isolation between the electric windings can be achieved. The power rating of the power electronics drive in VAG can be much smaller than the power rating of power transformers, which would greatly reduce the cost of device.

Key Words: Virtual airgap, fault, transformer, flux

1. INTRODUCTION

Now a day's importance of electricity increases day by day so we need to distribute electricity for utilization. So we use distribution transformer for distribution of electricity. But protection of distribution transformer is also very important. Because when fault occur on distribution system will be harmful for human life. That's why protection of transformer very important.

In this project we provide protection of distribution transformer by using virtual air gap concept. In this method we control secondary side current by controlling main flux in transformer core. The virtual air gap concept is used to control inrush current in transformer. The auxiliary winding used to produce opposite flux to main flux because of this principle reluctance of core increases and reluctance is inversely proportional to the flux and flux is directly proportional to the current. As a flux decreases current automatically.

2. CALCULATION

A. NOMENCLATURE

Apparent Power - Q

Primary Voltage - V_1

Secondary Voltage - V_2

Frequency - F

Design coefficient - k

Maximum flux density - B_m

Current density - D

E: Induced emf in Winding in volt

N_1 : Primary no. of turns

N_2 : Secondary no. of turns

I_1 : Current in primary winding in Amp

I_2 : Current in Secondary winding in Amp

d: diameter of conductor

H: height of winding in m

Φ_m : maximum flux in weber

A_c : Area of conductor in mm^2

B. SPECIFICATION

Q: 300 VA

V_1 : 230 volt

V_2 : 230 volt

F: 50 Hz

K: 0.59

B_m : 1 mwb

D: 3.3 amp/ mm^2

C. CALCULATIONS OF TRANSFORMER DESIGNING:

1) EMF/TURN

$$E_t = k * Q^{1/2}$$

$$E_t = 0.59(300 \times 10^{-3})^{1/2}$$

$$= 0.3231 \text{ volts}$$

2) Also EMF/TURN is

$$E_t = 4.44 F \Phi_m$$

$$\Phi_m = 1.4554 \text{ mwb}$$

3) Net Iron core area

$$\Phi_m = B_m \cdot A_i$$

Where A_i = Net core area in mm^2

$$A_i = 1455.65 \text{ mm}^2$$

4) Winding Design

$$N_1 = N_2 = V_2 / E_t$$

$$= 230 / 0.3231 = 711.85 = 712$$

From that, Turns Ratio

$$K = N_2 / N_1 = V_2 / V_1 = 1$$

Current $I_1 = I_2 = VA / V$

$$= 300 / 230 = 1.3034 \text{ Amp}$$

5) Conductor Area Calculations

$$A_c = I / D$$

But $I_1 = I_2$

so current density will be same

$$A_c = 1.3034 / 3.3$$

$$= 0.3952 \text{ mm}^2$$

A_c in SWG is 22 from that diameter of conductor is $d = 0.7111 \text{ mm}$

6) Core Dimensions:

Height of winding

$$H = N \cdot d / \text{layer} \quad (N = N_1 = N_2)$$

$$= 712 \cdot 0.711 / 4$$

$$= 126.59 \text{ mm}$$

Same for both winding, And add some tolerance

$$H = H + 10\%H$$

$$= 126.255 + 12.62 = 138.88 \text{ mm}$$

7) Width of winding /Parameter

W_1 = Width of Primary

$$W_1 = \text{layer} \cdot \text{Diameter} = 4 \cdot 0.3952 = 1.5808 \text{ mm}$$

$$W_1 = W_2$$

Bobbin thickness = 3mm (B_t)

Insulation Thickness = 4mm (I_t)

$$\text{Total Width } W_1 = 2 \cdot 1.5808 + (3+4)$$

$$= 10.1616 + 10\% \text{ of } (10.1616)$$

$$W_1 = W_2 = 11.1777 \text{ mm} = 12 \text{ mm}$$

$$W_T = W_1 + W_2 + W_t$$

$$= 12 \cdot 2 + 30 = 54 \text{ mm}$$

8) Shape of lamination

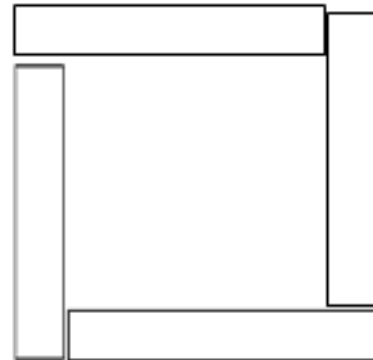

Plate	A	B	C	D
Lamination 1	98	38	19	19
Lamination 2	118	38	19	59

1) Thickness or Stack = 80 mm

2) Thickness or Stack = 80 mm

3) Hole Diameter = 10 mm

Height of Winding = HW

$$= N \cdot d / \text{layer}$$

$$50 = 712 \cdot 0.711 / \text{layer}$$

$$\text{Layer} = 10.1246 = 11$$

$W_T = (\text{Bobbin Width} + \text{Insulation Width} + \text{Winding Width}) + \text{Tertiary Clearance}$

$$= 2 \cdot (3+4+1.5808) + 40$$

$$W_T = 80 \text{ mm}$$

Result

A mm	B mm	C mm	D mm	E mm
38.1	114.3	95.3	19.1	15.9

3. BLOCK DIAGRAM

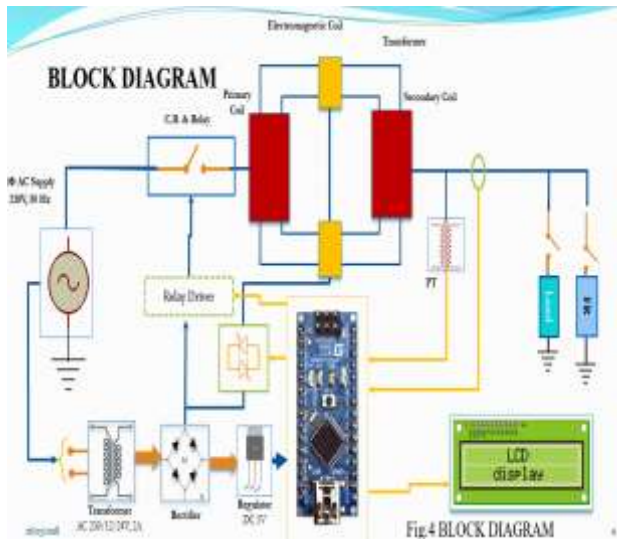

4. WORKING

Whenever we give single phase 230 volt 50 Hz supply to primary side of transformer then we get 230 volt at secondary side of transformer because transformation ratio of this transformer is one. Under normal condition transformer works safely and doesn't any overload current in transformer. In this process 3rd or DC winding remain deactivate from supply so there will be no production of opposite direction flux to main flux in transformer core. In case short circuit or overload current fault occur at load side then CT sense this fault current give signal to microcontroller. After microcontroller give signal driver circuit then driver circuit active the supply dc winding. This DC winding is low voltage and high current winding because to reduce core losses and reduce insulation cost. This DC winding produces magnetic dc flux in core due to application of dc supply because of this dc flux main flux will reduce and load current is directly proportional main flux in core. Whenever main flux decreases then load current also decreases. At the time of fault above principle is applicable and fault will reduces then circuit breaker contact will open and transformer will be protected from fault current.

5. CONCEPT OF VIRTUAL AIR GAP

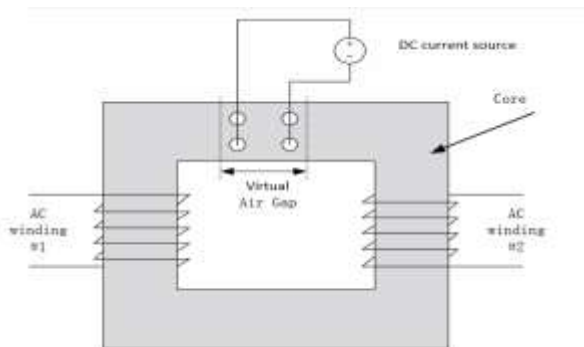

The virtual air gap is not actual air gap it like a saturated portion. So this saturated portion is created by wound a extra 3rd winding and give dc supply to this 3rd winding. Due this dc supply the constant dc flux is produced in that winding and setup of this winding is opposite direction to main flux winding. This constant flux will oppose to main flux and magnitude of fault will be decreases.

DC winding is activated by using TRAIC circuit and this winding is low voltage and high current. Magnitude dc winding current is depends on fault current in secondary winding of transformer.

6. COMPONENT OF PROJECT

1. Transformer
2. Switching circuit
3. Hall effect based Current sensor
4. Potential transformer
5. Arduino Nano controller
6. Relay
7. Power supply
8. LCD

a. TRANSFORMER

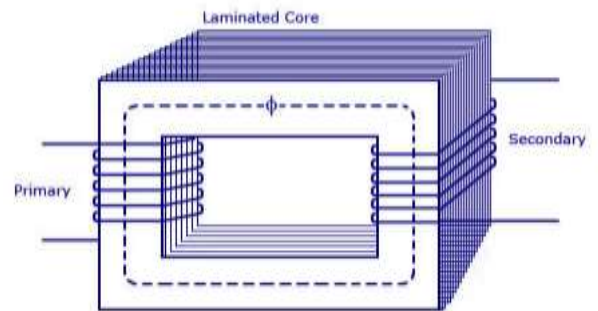

b. CURRENT SENSOR CIRCUIT



Hall Effect current sensor (ACS712) is used in this project. When current flowing through the conductor magnetic field is produced in that conductor. Whenever field is produced

then emf is induced in hall plate this emf is compared with Hall Effect current sensor voltage. Then difference is produced in both voltages and this difference of voltages gives proportional current to micro controller.

1. When voltage difference is positive then current will be rise.
2. When voltage difference is negative current will be reduce.

c. POTENTIAL TRANSFORMER

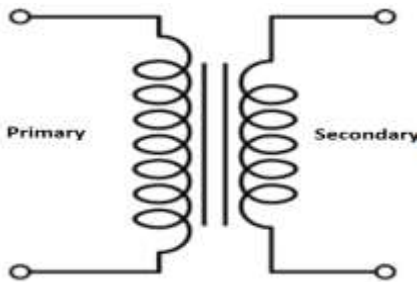

Potential transformer (PT) is used for measurement of voltage as well as used for protection of transformer. 230v to 6v PT is used in this project. In PT primary winding is high voltage winding and secondary winding is low voltage winding.

d. ARDUINO NANO CONTROLLER

Arduino nano atmega 328p controller is used in this project. This controller has 30 pin IC. High performance, low power AVR 8 bit microcontroller. 32K Bytes flash memory and 1K bytes EPROM is used. The RAM is used in Atmega 328p is 2K Bytes. The oscillatory frequency of At mega 328p is 4 MHz Power-on Reset and Programmable Brown-out Detection and Internal Calibrated Oscillator.

e. RELAY

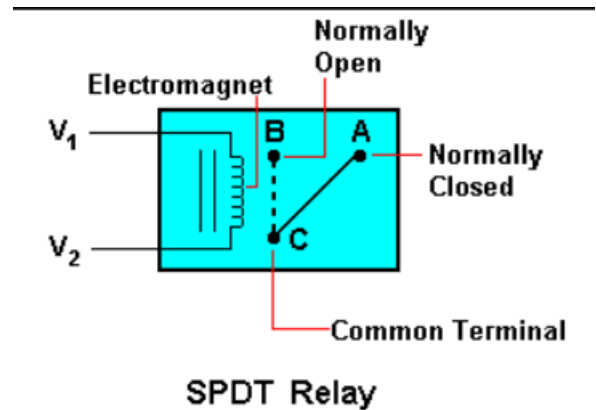

Relay is basically sensing device which is sense the overload current. Under normal condition relay coil is de-energies. But when overload current is start to flowing through relay coil then the relay coil will be energies. As the relay coil energies then normally open contacts gets closed. In this project single pole double through (SPDT) relay is used. The rating of this relay is 10A and 220v AC/DC.

f. POWER SUPPLY

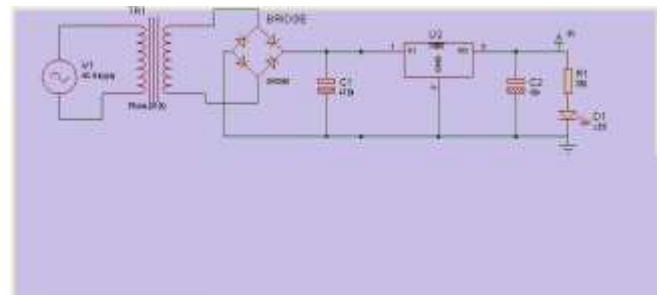

The above power supply circuit provide 9v source to Atmega 328p IC and also this supply is provided to driver IC. The input voltage of power supply circuit 230v and output voltage is 9v. The regulator IC used in it is 7809. When supply voltage is given to bridge rectifier then the ac supply is converted in dc supply. The output of rectifier is not pure due this we connect the parallel capacitor to reduce harmonic in rectifier output. After the capacitor connect the regulator IC7809 to get regulated supply. i.e. 9v

g. LCD

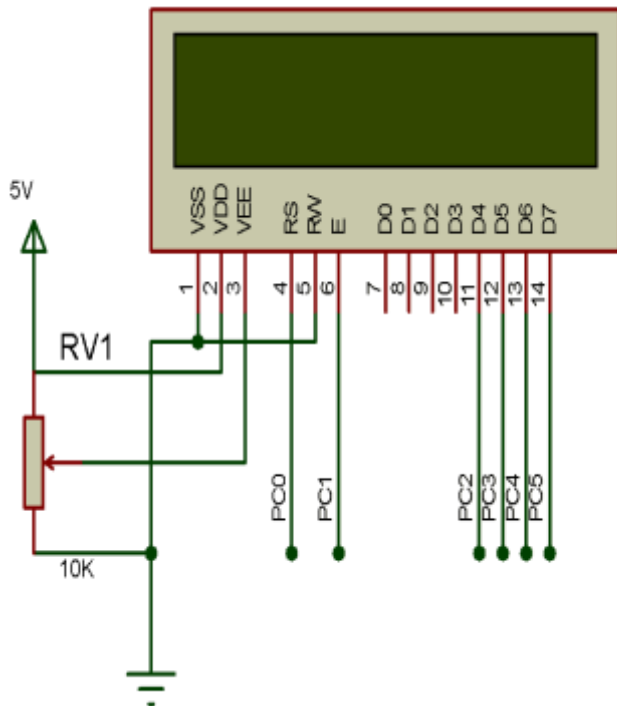

Liquid crystal display: 20*4 character.

This LCD is mechanically & electrically interchangeable with 20*4 LCDS. It operate at 5volt resistor should be 10 Kilo ohm

7. CONCLUSION:

In this project, we concluded that Virtual air gap method is used for protection of transformer from short circuit current. Because of this project also reduces the cost of current limiting reactor. Hence we use the VAG method for reducing the value of inrush fault current. This project is useful for distribution level we can replace all the conventional transformer by this VAG based transformer.

8 REFERENCES

[1] Reuben lee and Donald s. Stephens IEEE transaction on magnetics , vol. Mag-9, no.3 September 1973

[2] Dr. Yuechang zhang (novel power transformer with fault current limiting capability).

[3] Asphaq hussain (ref. Book -electrical machine)

[4] B. L. Thareja (ref. Book of electrical technology volume 2)

[5] Hameyer, Kay (2001). "Electrical Machines I: Basics, Design, Function, Operation". RWTH Aachen University Institute of Electrical Machines. p. 27.

[6] Mehta, S.P.; Aversa, N.; Walker, M.S. (Jul 1997). "Transforming Transformers [Superconducting windings]".IEEE Spectrum**34** (7): 43-49. doi:10.1109/6.609815. Retrieved 14 November 2012.

[7] ANSI/IEEE C57.13, ANS Requirements for Instrument Transformers. New York, N.Y.: IEEE. 1978 (superseded, 1993). p. 4 (\$3.26).ISBN 0-7381-4299-9.

[8] Parker, M. R; Ula, S.; Webb, W. E. (2005). Whitaker, Jerry C., ed. "The Electronics Handbook" (2nd ed.). Taylor & Francis.pp. 172, 1017.ISBN 0-8493-1889-0.

[9] Miller, Wilhelm C.; Robbins, Allan H. (2013). Circuit analysis : theory and practice (5th ed.). Clifton Park, NY: Cengage Learning. p. 990.ISBN 978-1-1332-8100-9.Retrieved 25 September 2014.

[10] Hameyer, Kay (2001). "Electrical Machines I: Basics, Design, Function, Operation". RWTH Aachen University Institute of Electrical Machines.p. 27.

[11] International application published under patent cooperation treaty (PCT) (19) World Intelligent property, (43) International publication Date 9 June 2016 (09.06.2016) WIPO PCT WO 2016/089351 A1

BIOGRAPHIES



Mr. SHARAD S. KHADE
Student Of Electrical Engg.
Contact-9011363503
Email-
sharadkhade143@gmail.com



Mr. Sidhaganesh M. Gote
Student Of Electrical Engg.
Contact-9689673110
Email-smgote1996@gmail.com



Asst. Prof. Ranjit M. Zende
Asst. Prof. of Electrical Engg.
Contact-97630330081
Email-zende.ranjit04@gmail.com