

# Enhancing the Performance of Hybrid Microgrid using Non Isolated Single Stage Three Port Converter: A Review

<sup>1</sup>Prashast Singh Parihar, <sup>2</sup>Suresh Kumar Gawre, <sup>3</sup>Arun Rathore

<sup>1,2,3</sup>Department of Electrical Engineering, MANIT, Bhopal, INDIA

\*\*\*

*Abstract— Microgrid has become a milestone in the field of distributed generation with advent of renewable energy resources and rapidly improving storage system. The Hybrid microgrid is a combination of both AC and DC subgrids which incorporates in it benefits of both type of grids as efficiency is increased and cost is reduced owing to less number of power conversions. The ac-dc subgrids of a hybrid microgrid are connected through interlinking bidirectional AC-DC converter and storage system can be connected to either of the two sides. In conventional hybrid microgrids because of storage system integration, device count and number of power conversion increases hence overall performance decreases because of reduced power quality and increased frequency deviation. This paper presents a detailed literature review of a non isolated single stage three port converter(NISSTPC) for hybrid microgrid applications. NISSTPC has three bidirectional ports connected to AC side DC side and storage system. There is single stage power conversion in NISSTPC owing to which power conversion efficiency and power quality increases. In this paper we have also compared NISSTPC with conventional hybrid microgrids in the parameters of power quality, frequency deviation and availability of storage during fault situations. From the studies it can be concluded that overall performance of hybrid microgrid improves with NISSTPC converter*

**Key Words—Hybrid microgrid; three-port converter; power Quality; single stage inverter; DC-DC converter.**

## 1. INTRODUCTION

With the increase of global warming & increasing concerns regarding it Renewable Energy based distributed generation system is gaining prominence day by day. Distributed generation based on solar PV

cells, wind energy & biomass will gain further momentum in coming time. A microgrid consists of clusters of load & distributed generation as a single controlled system. Microgrid operates in 2 modes:-

1. Grid connected mode-In this mode microgrid is connected to main grid through point of common coupling (PCC)

2. Islanded mode-In this mode microgrid is not connected to main grid & operates individually

## TYPES OF MICROGRIDS [1] [4]:

Microgrids are basically of three types

1. AC MICROGRID: It has centralised AC BUS Architecture and is used when generating source is AC ex, WIND11
2. DC MICROGRID: It has centralised DC BUS Architecture and is used when source is DC ex. SOLAR PV system
3. HYBRID MICROGRID: It is a modular solution which connects various heterogeneous Loads and sources. It Comprises of AC subgrid, DC subgrid and storage systems All the AC Loads are connected to AC side Bus, DC loads to DC side bus and AC-DC buses are connected through Bidirectional AC-DC Converter.

The storage system can be connected to AC Side, DC side or both sides[2]. Based on storage system connection Hybrid Microgrids are classified as AC side storage Hybrid Microgrid(ACS), DC side storage Microgrid (DCS), AC-DC side storage Microgrid (ADS) & NISSTPC as shown in fig,1(a),1(b), 1(c), 1(d) respectively. The drawbacks of conventional microgrid systems [3]are ;

1. More number of conversions required to transfer power from one source to another
2. Power quality issues, because of more number of converters.
3. Centralized control is not possible
4. The effective utilization of storage system is less.
5. Component count and overall cost increases appreciably.
6. Decreased power density and efficiency

Multi port converter (MPC) design is a newly flourishing technology for integration of various heterogeneous energy sources. MPC reduces the number of power conversions, number of devices, hence there is a improvement in efficiency MPCs can be classified as follows:

- 1) Based on number of inputs and outputs
  - (a) multiple inputs multiple outputs [12], [18]
  - (b) multiple inputs single output [10], [24]and[26]
  - (c) Single input multiple outputs [16].
- 2) Based on converter topology:
  - (a) isolated converters [6-10], [12], [17-20],[27-33]
  - (b) non-isolated converters [2], [11], [13-14] [16], [21-22], and [25]
  - (c) Partially isolated converters [15], [18], [24].
- 3) Based on power conversion type:
  - (a) DC to DC converters [6-7], [9-13], [15-22],
  - (b) DC to AC/DC converters [14], and
  - (c) AC to DC/AC converters [33].

The MPC concept discussed in Literature by several researchers [4].Due to simpler structure , Less number of devices & high efficiency they find the place in various applications like Uninterrupted power supply, Hybrid electric vehicles & various Marine Applications. Major designs of MPCs are for DC-DC power conversion. But, in the hybrid micro-grid architecture, DC-AC/DC, AC-DC/DC and AC-DC/AC[35] converter are required to integrate the AC sub-grid, DC sub-grid and storage systems. On this basic, we intend to discuss a newly proposed converter topology named as non-isolated single stage three-port converter (NISSTPC) which is having AC microgrid port, DC microgrid port and storage port. It can integrate all the three systems effectively .The hybrid microgrid system along with the three-port converter is named as TPCS microgrid architecture.

NISSTPC has three bi-directional ports, which are connected to AC and DC sub grids, storage system.

Single stage power conversion is possible either side using NISSTPC. Because of this single stage power conversion of NISSTPC the power quality and conversion efficiency of hybrid microgrid system is increased. The organization of paper is as follows: Section 2 describes the NISSTPC topology, control scheme and its modes of operation. Section 3 presents the comparative results of the NISSTPC Topology on the parameters of power quality, frequency deviation and utilization of storage system with conventional hybrid microgrid architectures and, section 4 tells about the key challenges, section 5 tells about conclusions and future prospects of this topology.

## 2. NISSTPC TOPOLOGY MODELLING CONTROL AND MODES OF OPERATION

### A.MODELING OF NISSTPC

The topology of the NISSTPC [2] is shown in Fig.2 This topology is modeled using 7 switches; among them four switches SW1-SW4 are for bidirectional AC-DC operation and rest. three switches T1-T3 are for DC-DC buck/boost conversion operation.  $V_{dcH}$ ;  $V_{dcL}$  and  $V_{ac}$  are the voltage across DC sub- grid(solar energy PV grid), storage system and AC sub- grid(solar energy PV grid), storage system and AC sub-grid(Wind energy grid) respectively.

Fig. 1 Microgrids based on storage system

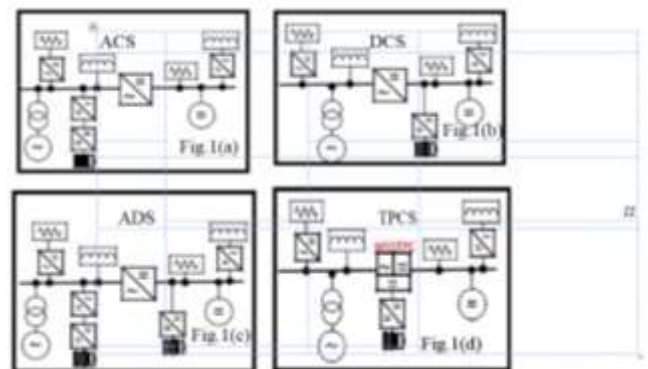

### integration

Inductor (L) , Capacitor (C) are for buck/boost operations. Diode (D) connected between switches P1 and P3 for inhibiting the reverse power flow. The current through these converters are  $i_{ac}$ ,  $i_{dcL}$  &  $i_{dcH}$ . The AC, low DC and high DC represent the wind energy system, storage system and solar PV system

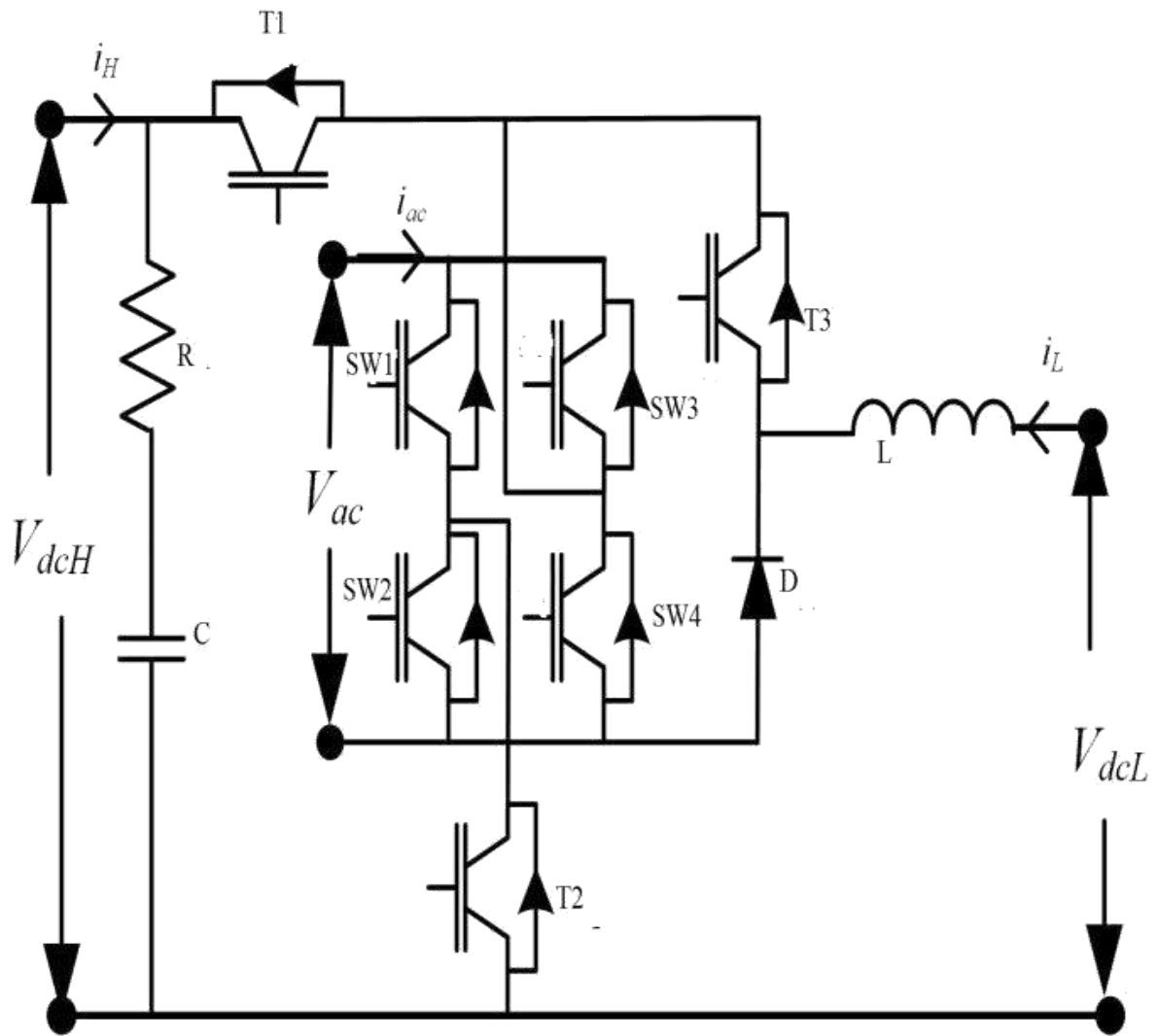

Fig.2 NISSTPC TOPOLOGY

**SWITCHING STATES OF NISSTPC**

Mode	Interval	Switching states of switches (1 ON; 0 OFF)							Path of Current	Voltage profile
		SW <sub>1</sub>	SW <sub>2</sub>	SW <sub>3</sub>	SW <sub>4</sub>	T <sub>1</sub>	T <sub>2</sub>	T <sub>3</sub>		
I	1	0	1	1	0	1	1	0	T <sub>1</sub> - SW <sub>2</sub> - V <sub>ac</sub> - SW <sub>3</sub> - T <sub>2</sub>	Positive V <sub>ac</sub> is available at the AC
	2	1	0	0	1	1	1	0	T <sub>1</sub> - V <sub>ac</sub> - SW <sub>1</sub> - T <sub>2</sub>	Negative V <sub>ac</sub> is available at the AC
II	1	1	0	1	0	0	1	1	L - T <sub>3</sub> - SW <sub>1</sub> - SW <sub>3</sub> - T <sub>2</sub>	Shoot through interval for boost voltage.
	2	0	1	1	0	0	1	1	L; T <sub>3</sub> - SW <sub>2</sub> - V <sub>ac</sub> - SW <sub>3</sub> - T <sub>2</sub>	Positive V <sub>ac</sub> is available at the AC
	3	1	0	0	1	0	1	1	L; T <sub>3</sub> - SW <sub>4</sub> - V <sub>ac</sub> - SW <sub>1</sub> - T <sub>2</sub>	Negative V <sub>ac</sub> is available at the AC
III	1	0	1	0	0	0	1	0	T <sub>2</sub> - SW <sub>2</sub> - D - L	Shoot through interval for buck voltage
	2	0	0	0	0	1	0	1	T <sub>1</sub> - T <sub>3</sub> - L	Buck voltage operation
IV	1	1	0	1	0	0	1	1	L - T <sub>3</sub> - SW <sub>1</sub> - SW <sub>3</sub> - T <sub>2</sub>	Shoot through interval for boost voltage
	2	0	1	1	0	1	1	1	T <sub>1</sub> ; L; T <sub>3</sub> - SW <sub>2</sub> - V <sub>ac</sub> - SW <sub>3</sub> - T <sub>2</sub>	Positive V <sub>ac</sub> is available at the AC
	3	1	0	0	1	1	1	1	T <sub>1</sub> ; L; T <sub>3</sub> - SW <sub>4</sub> - V <sub>ac</sub> - SW <sub>1</sub> - T <sub>2</sub>	Negative V <sub>ac</sub> is available at the AC
V	1	0	1	1	0	1	0	1	T <sub>1</sub> - SW <sub>2</sub> - SW <sub>3</sub> - T <sub>3</sub> - L	Buck voltage from positive V <sub>ac</sub> .
	2	0	1	1	0	0	1	1	T <sub>2</sub> - SW <sub>2</sub> - SW <sub>3</sub> - T <sub>3</sub> - L	Shoot through interval for buck voltage
	3	1	0	0	1	1	0	1	T <sub>1</sub> - SW <sub>1</sub> - SW <sub>4</sub> - T <sub>3</sub> - L	Buck voltage from negative V <sub>ac</sub> .
	4	1	0	0	1	0	1	1	T <sub>2</sub> - SW <sub>1</sub> - SW <sub>4</sub> - T <sub>3</sub> - L	Shoot through 0 interval for buck voltage
VI	1	0	1	1	0	1	1	0	T <sub>1</sub> - SW <sub>2</sub> - V <sub>ac</sub> - SW <sub>3</sub> - T <sub>2</sub>	Positive V <sub>ac</sub> available at the AC
	2	0	1	0	0	0	1	0	T <sub>2</sub> - SW <sub>2</sub> - D - L	Shoot through interval for buck voltage
	3	0	0	0	0	1	0	1	T <sub>1</sub> - T <sub>3</sub> - L	Buck voltage operation
	4	1	0	0	1	1	1	0	T <sub>1</sub> - SW <sub>4</sub> - V <sub>ac</sub> - SW <sub>1</sub> - T <sub>2</sub>	Negative V <sub>ac</sub> is available at the AC

### B. CONTROL OF NISSTPC

The control scheme used for controlling the NISSTPC is shown in Fig. 4. It consists of five stages as follows

Stage-1: The carrier signal C1, C2, C3 and C4 are generated based on the duty ratio value with respect to  $I_{dL}$ ,  $I_{dH}$ ,  $I_{ac}$

Stage -2: The carrier signals above reference sine wave give 0 or 1. The control pulses for positive and negative half cycles are generated by compared reference signal with carrier signals  $C_{x1}$ ,  $C_{x2}$ ,  $C_{y1}$  and  $C_{y2}$ .

Stage-3: The aggregate signal generation is done via control pulses with addition of +1 or -1. The aggregate signal leads to generation of inverter's desired output level.

Stage-4: Finally, look-up table (Table I) formulation is done based on the topology which produces gate signals required for switches SW1-SW4 of NISSTPC for its operation.

Stage -5: The formulation for look up table of switches T1 -T3 of NISSTPC is done based on duty ratio values.

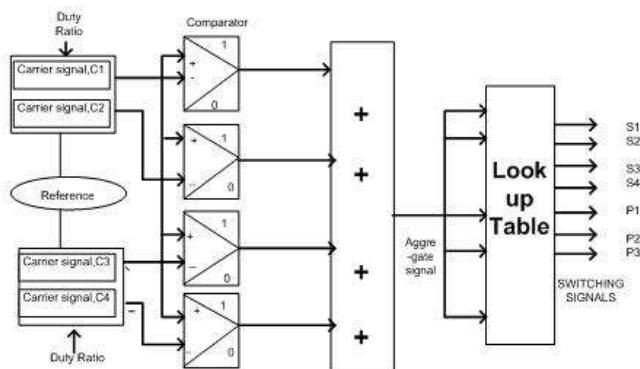

Fig.3 Control Block of NISSTPC

### C. Operating Modes of NISSTPC

The NISSTPC performs six different operating modes as shown in Fig. 4. Here  $V_{dCH}$ ;  $V_{dCL}$  and  $V_{ac}$  are the voltage across DC sub-grid, storage system and AC sub-grid source or between AC source and storage system. Modes IV-VI are dual power flow modes in which power flow is simultaneously in between three-ports.

The NISSTPC operation and it's switching states in different interval of time under different modes are explained in Table I.

Mode I: In this mode of operation, storage system is disconnected, and NISSTPC provides unidirectional power flow from DC side to AC side (Boost DC to AC).

Mode II: In this mode of operation, DC source is disconnected and NISSTPC provides bi-directional power flow in between AC source and storage system (Bi directional buck DC to AC).

Mode III: In this mode of operation, AC source is islanded and NISSTPC provide the unidirectional power flow in between DC source and storage system(DC buck to boost DC).

Mode IV: In this mode of operation, NISSTPC unidirectional provides power to AC source from boost DC source and storage system (Boost DC/buck DC to AC).

Mode V: In this mode of operation, battery (storage system) charges from AC source and DC source and NISSTPC acts as Boost DC/AC to buck DC converter.

Mode VI: In this mode of operation, battery and AC source consumes power form DC source and the NISSTPC converts DC Boost voltage to AC and Buck DC.

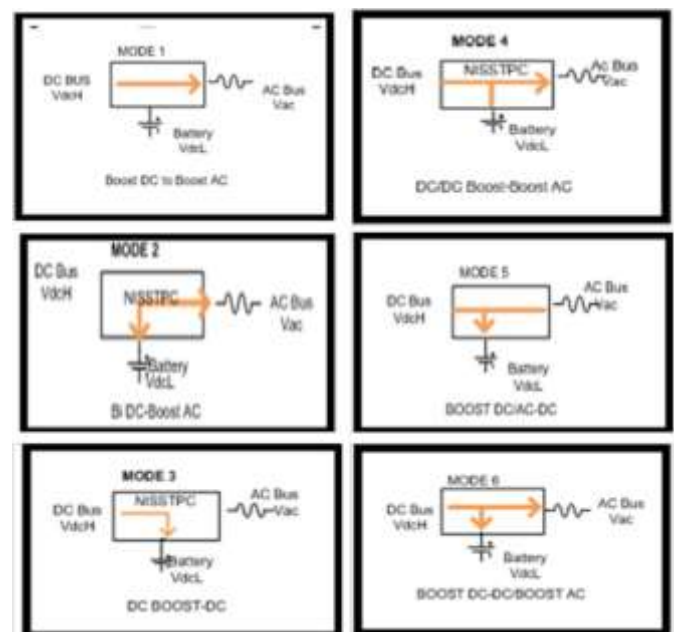

Fig.4 Modes of operation of NISSTPC



### 3. COMPARATIVE STUDY OF NISSTPC

The NISSTPC has been represented by the name TPCS & results are compared with ACS(ac side storage),DCS(dc side storage) & ADS(ac-dc side storage)

**Power Quality:** THD(Total harmonic distortion) gives the information about power quality & from the studies it has been found that in Modes I IV & V AC subgrid behave as a Load so power quality is poorer in these modes compared to the other modes. As per the research studies [2] THD of various topologies are tabulated in Table II & it is a clear observation that TPCS has better power quality than all the other topologies

#### Storage availability during Faults:

As per the study it has been found that in ACS both the storage system & ac sub grid is isolated. In DCS storage system & DC sub grid are isolated. In DCS any of the ac/dc sub grid leads to partial unavailability of storage system ,but in case of TPCS storage system is not isolated irrespective of Fault location so it helps in meeting the load demand in emergency situations. In ADS there is partial availability of storage which may not meet the load demand completely but in TPCs full storage system is available hence load demand can be completely satisfied. So TPCs also provides better storage system management as tabulated in Table II

As per the above studies TPCS is compared with the other conventional microgrid topologies & is tabulated in Table 3 and this is quite evident that TPCS with NISSTPC topology is better in performance than the remaining in all parameters

**TABLE II: STORAGE SYSTEM AVAILABILITY DURING FAULTS**

Storage system	Fault on AC sub-grid	Fault on DC sub- grid
Storage on ACS	Isolated	Not isolated
Storage on DCS	Not isolated	Isolated
Storage on ACS	DC sub-grid storage	AC sub-grid storage
Storage on TPCS	Not isolated	Not isolated

**TABLE III: Comparison between conventional mocro grids and TPCS Microgrid**

Parameter	ACS	DCS	ADS	TPCS
Frequency Deviation	Medium	High	Medium	Less
Power Quality	Less	Moderate	Less	High
Storage Utilization	No	No	Partial	Full

### 4. KEY POINTS & CHALLENGES:

From the studies it is clearly evident that TPCS with NISSTPC is better in performance than all remaining conventional Topologies in all Parameters & thus paves the way for future Hybrid Microgrid Applications.

Issues like Power quality & storage availability which have been the prime concer4n in the context of Micro grids have been effectively sorted out.

More over 2 different renewable energy systems like wind & solar PV system can be simultaneously connected together in this system & this helps in much improved utilization of renewable energy systems & can work as good stand alone systems in Far off locations. The major challenge will be connection with utility grid & synchronization with utility grid which is the future scope of this study which we intend to do in future so that can aid in its more effective utilization & this systems becomes pioneer in renewable energy utilization.

### 5. CONCLUSIONS:

In this paper we have studied the Non isolated single stage three port converter for hybrid microgrid applications the advantages of NISSTPC topologies are as follows:

1. It's frequency deviation is lesser than other topologies.
2. It's THD is lesser than other topologies.

3. Storage Management is much effective when compared to rest.
4. There is single stage power conversion in all modes so efficiency is higher.
5. Lesser number of devices are required for power transfer from one side to another.
6. Device count is lesser for the amount of power transferred.
7. It provides the opportunity to link 2 different renewable energy sources namely, wind & solar to work simultaneously together thus more effective renewable energy utilization.
8. It can help in standalone renewable energy power plants in Far off locations where both solar & wind energy are abundantly available ex. Western Rajasthan, Kutch (Gujarat,India).
9. IOT based control of micro grid is one of the possible feature for the future which can help us in smart controlling & monitoring of both the AC,DC sub grids & storage systems & hence both the renewable energy systems used can be effectively managed.
10. Multiple sources can be integrated to AC & DC buses with the help of multi level inverters,& DC-DC Boost converters & hence the future expansion can take place.
11. With the help of multi port technology we can use the available AC/DC output for various applications like Hybrid Electric vehicle(EV)[37] charging via Dc output ports.
12. In future with the multi level inverters & BUCK/BOOST DC -DC converters [35][36] ,using multiport technology we can obtain different voltage levels or different utility applications as well.

Hence by this study it can be effectively concluded that performance of hybrid microgrid is significantly improved by non isolated single stage three port converter & there are various future applications possible with this topology

## References

- [1] D. Wu, F. Tang, J. C. Vasquez, T. Dragicevic, and J. M. Guerrero, "Autonomous Active Power Control for Islanded AC Microgrids With Photovoltaic Generation and Energy Storage System," *IEEE Trans. on Ind. Applicat.*, vol. 51, no. 1, pp. 336-343, 2015.
- [2] Pinjala Mohana Kishore , Ravikumar Bhimasingu , "A Non-isolated Single Stage Three-port Converter for Hybrid Microgrid Applications", *Sustainable Green Buildings and Communities (SGBC) international conference on IEEE,2016*
- [3] N. Eghtedarpour and E. Farjah, "Power Control and Management in a Hybrid AC-DC Microgrid," *IEEE Trans. Smart Grid*, vol. 5, no. 3, pp. 1494-1505, 2014.
- [4] Estefania Planas ,Jon Andreau,Jose Ignacio Garate ,Inigo Martinez de Algeria ,Edorta Ibarra "AC and DC technology in microgrids: A review",*Renewable and sustainable energy reviews,43(2015) 726-749*
- [5] Z. Rehman, I. Al-Bahadly, and S. Mukhopadhyay, "Multiinput DC-DC converters in renewable energy applications-An overview," *Renewable and Sustainable Energy Reviews*, vol. 41, pp. 521-539, 2015.
- [6] L. J. Chien, J. F. Chen, C. C. Chen, and Y. P. Hsieh,, "Novel -Three port Converter With High-Voltage-Gain," *IEEE Trans. Power Electron.*, vol. 29, no. 9, pp. 4693-\$4703, 2014.
- [7] J. Zeng, L. Qu, and W. Qiao, "An isolated -Three port bidirectional DC-DC converter for photovoltaic systems with energy storage," *2013 IEEE Industry Applications Society Annual Meeting, Orlando, USA, 2017*
- [8] H. Wu, R. Chen, K. Sun, H. Hu, and Y. Xing, "Fullbridge -Three port Converters With Wide Input Voltage Range for Renewable Power Systems," *IEEE Trans. Power Electron.*, vol. 27, no. 9, pp. 3965-3974, 2012.
- [9] H. Tao, M. Hendrix, and J. Duarte, "Three Port Triple Half Bridge Bidirectional Converter With Zero Voltage Switching," *IEEE Trans.Power Electron.*, vol. 23, no. 2, pp. 782-792, 2008S.

- [10] Falcones and R. Ayyanar, "DC-DC Multi-port Converter Based Solid State Transformer Integrating Distributed Generation and Storage," *IEEE Trans. Power Electron.*, vol. 28, no. 5, pp. 2192-2203, 2013.
- [11] H. Wu, J. Zhang, and Y. Xing, "A Family of Multi-port Buck-Boost Converters Based on DC-Link-Inductors," *IEEE Trans. Power Electron.*, vol. 30, no. 2, pp. 735-746, 2015.
- [12] S. Dusmez, X. Li, and B. Akin, "A New Multiinput Three Level DC-DC Converter," *IEEE Trans. Power Electron.*, vol. 31, no. 2, pp. 1230-1240, 2016
- [13] Z. Zhou, X. Ma, H. Wu, and Y. Xing, "A non isolated three port converter for stand-alone renewable power system," *IECON 2012 - 38th Annual Conference on IEEE Industrial Electronics Society*, Montreal, Canada, 2012.
- [14] W. Cai, L. Jiang, S. Duan, and C. Zou, "A Power Decoupling Method Based on Four Switch Three Port DC/DC/AC Converter in Microgrid," *IEEE Trans. Ind. Applicat.*, vol. 51, no. 1, pp. 336-343, 2015.
- [15] X. Sun, W. Li, Y. Shen, and H. Wu, "A PWM and PFM Hybrid Modulated -Three port Converter for a Standalone PV/Battery Power System," *IEEE J. Emerg. Sel. Topics Power Electron.*, vol. 3, no. 4,
- [16] A. Patra, P. Patra, and N. Misra, "A Single Inductor Multiple-Output Switcher With Simultaneous Buck, Boost, and Inverted Outputs," *IEEE Trans. Power Electron.*, vol. 27, no. 4, pp. 1936-1951, 2012.
- [17] H. Tao, J. Duarte, A. Kotsopoulos, and M. Hendrix, "A Soft-Switched -Three port Bidirectional Converter for Fuel Cell and Super capacitor Applications," *IEEE 36th Conf. on Power Electron. Special*, 2005.
- [18] D. Liu and H. Li, "A ZVS Bi-Directional DC-DC Converter for Multiple Energy Storage Elements," *IEEE Trans. Power Electron.*, vol. 21, no. 5,
- [19] H. Wu, K. Sun, L. Zhu, and Y. Xing, "An Interleaved Half Bridge -Three port Converter with Enhanced Power Transfer Capability Using Three Leg Rectifier for Renewable Energy Applications," *IEEE J. Emerg. Sel. Topics Power Electron.*, 1-6, 2015.
- [20] M. Phattanasak, R. G. Ghoachani, B. N. Mobarakeh, J. P. Martin, S. Pierfederici, and B. Davat, "Control of a Hybrid Energy Source Comprising a Fuel Cell and Two Storage Devices Using Isolated -Three port Bidirectional DC-DC Converters," *IEEE Trans. on Ind. Applicat.*, vol. 51, no. 1, pp. 491-497, 2015.
- [21] H. Zhu, B. Zhang, D. Zhang, and Z. Zhou, "A Nonisolated -Three port DC-DC Converter and Three-Domain Control Method for PV Battery Power Systems," *IEEE Trans. Ind. Electron.*, vol. 62, no. 8, pp. 4937-4947, 2015
- [22] O. Ray, S. Mishra, A. P. Josyula, and A. Joshi, "Integrated Dual-Output Converter," *IEEE Trans. Ind. Electron.*, vol. 62, no. 1, pp. 371-382, 2015
- [23] H. Wu, J. Zhang, R. Chen, Y. Xing, and H. Hu, "A Family of -Three port Half Bridge Converters for a Standalone Renewable Power System," *IEEE Trans. Power Electron.*, vol. 26, no. 9, pp. 2697-2706, 2011.
- [24] R.-J. Wai, C.-Y. Lin, and Y.-R. Chang, "High Step-Up Bi-directional Isolated Converter With Two Input Power Sources," *IEEE Trans. Ind. Electron.*, vol. 56, no. 7, pp. 2629-2643, 2009.
- [25] F. Nejabatkhah, S. H. Hosseini, S. Danyali, M. Sabahi, and S. M. Niapour, "Modeling and Control of a New Three-Input DC-DC Boost Converter for Hybrid PV/FC/Battery Power System," *IEEE Trans. Power Electron.*, vol. 27, no. 5, pp. 2309-2324, 2012.
- [26] R.-J. Wai, J.-J. Liaw, C.-Y. Lin, and Y.-R. Chang, "Newly Designed ZVS Multi-Input Converter," *IEEE Trans. Ind. Electron.*, vol. 58, no. 2, pp. 555-566, 2011.
- [27] W. Li, Y. Zhao, J. Xiao, and X. He, "PWM Plus Phase Angleshift Control Scheme for Combined Multi-port DC-DC Converters," *IEEE Trans. Power Electron.*, vol. 27, no. 3, pp. 1479-1489, 2012.
- [28] H. Wu, X. Qin, J. Zhang, T. Mu, and Y. Xing, "Secondary-Side Regulated Soft-Switching Fullbridge -Three port Converter Based on Bridgeless Boost Rectifier and Bi-directional



- Converter For Multiple Energy Interface,” IEEE Trans. Power Electron., pp. 1-6, 2015.
- [29] W. Li, X. He, Y. He, Y. Sun, F. Wang, and L. Ma, “Series Asymmetrical Half-bridge Converters With Voltage Autobalance for High Input Voltage Applications,” IEEE Trans. Power Electron., vol. 28, no. 8, pp. 3665-3674, 2013.
- [30] H. Krishnaswami and N. Mohan, “-Three port Series Resonant DC-DC Converter to Interface Renewable Energy Sources With Bi-directional Load and Energy Storage Ports,” IEEE Trans. Power Electron., vol. 24, no. 10, pp. 2289-2297, 2009.
- [31] Y. Hu, W. Cao, W. Xiao, B. Ji, and D. J. Morrow, “Three-Port DC-DC Converter for Standalone Photovoltaic Systems,” IEEE Trans. Power Electron., vol. 30, no. 6, pp. 3068-3076, 2015.
- [32] H. Wu, S. Ding, K. Sun, and Y. Xing, “Topology Derivation of Non isolated -Three port DC-DC Converters From DIC and DOC,” IEEE Trans. Power Electron., vol. 28, no. 7, pp. 3297-3307, 2013.
- [33] P M Kishore, B Ravikumar, “Improving the Performance of Hybrid Microgrid using Isolated Three-port Converter,” In proc. of IEEE International Conference on Power Electronics, Intelligent Control and Energy Systems, India, 2016.
- [34] A.A.Eajal ,Mohamed A.Abdelwahed, E.F.El-Saddany, Kumaraswami Poonambalam, “ A unified approach to power flow analysis of AC DC Hybrid Microgrids” IEEE transaction on sustainable energy, Vol.7 No.3 July 2016
- [35] Pinjala Mohan Kishore and Ravikumar Bhimasingu, “ A simplified converter with simultaneous Multi Level AC & Boost DC Outputs for Hybrid Microgrid Applications”,
- [36] N. Kumar, S.K.Gawre , D.Verma , “Modelling and simulation of Neutral Point Clamped Multi level Inverter for solar Photovoltaic System”, International Conference on Advances in Engineering and Technology (ICAET 2014)7
- [37] S. K .Gawre , T .Sarkar , M. Sharma , “A Generalized approach to design the electrical power system of solar electric vehicle” ,Electrical ,Electronics and Computer Science (SCEECS), 2014 IEEE Students